



CHAPTER OVERVIEW

Operating Instructions

A

ECC - Electronic Compressor Control (if equipped).....

B

Spare Parts Lists

C

Options (if equipped).....

D

Attachment

E

Manufacturer in terms of 97/23/EC

The full name and address of the manufacturer is:

Lenhardt & Wagner GmbH

An der Tuchbleiche 39

68623 Hüttenfeld / Germany

Phone: +49 (0) 62 56 - 85 88 0 - 0

Fax: +49 (0) 62 56 - 85 88 0 - 14

E-Mail: service@lw-compressors.com

Internet: www.lw-compressors.com





SERVICE INFORMATION / WARRANTY

Compressor information

Type designation

Serial number

Date of construction

Purchase information

Purchase date

First commissioned on

Warranty period

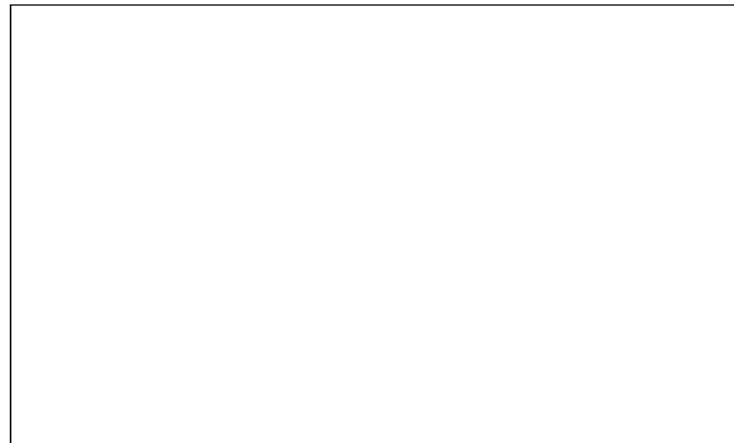

Dealer's stamp

Warranty

L&W will uphold warranty claims made during a period of 12 months from the invoice date.

If the compressor was purchased from an official L&W dealer, the date on the dealer's invoice is valid. Warranty claims can only be made on presentation of the original invoice.

Should verifiably defective parts have been delivered, we will decide to either replace the parts or repair them. The resulting transport and assembly costs will be invoiced.

No reduction of the purchase price or changes to the contract can be made. The parts for which a claim is being made should be kept safe by the purchaser and, when requested, sent to us at their cost. Replaced parts become the property of L&W. If maintenance work is carried out without our knowledge or permission by the purchaser or a third party, we are absolved from any liability for warranty claims. As a matter of principle, warranty claims can only be made by the initial purchaser.

Operating Instructions

Breathing Air Compressor

LW 300 EC III / LW 450 EC III

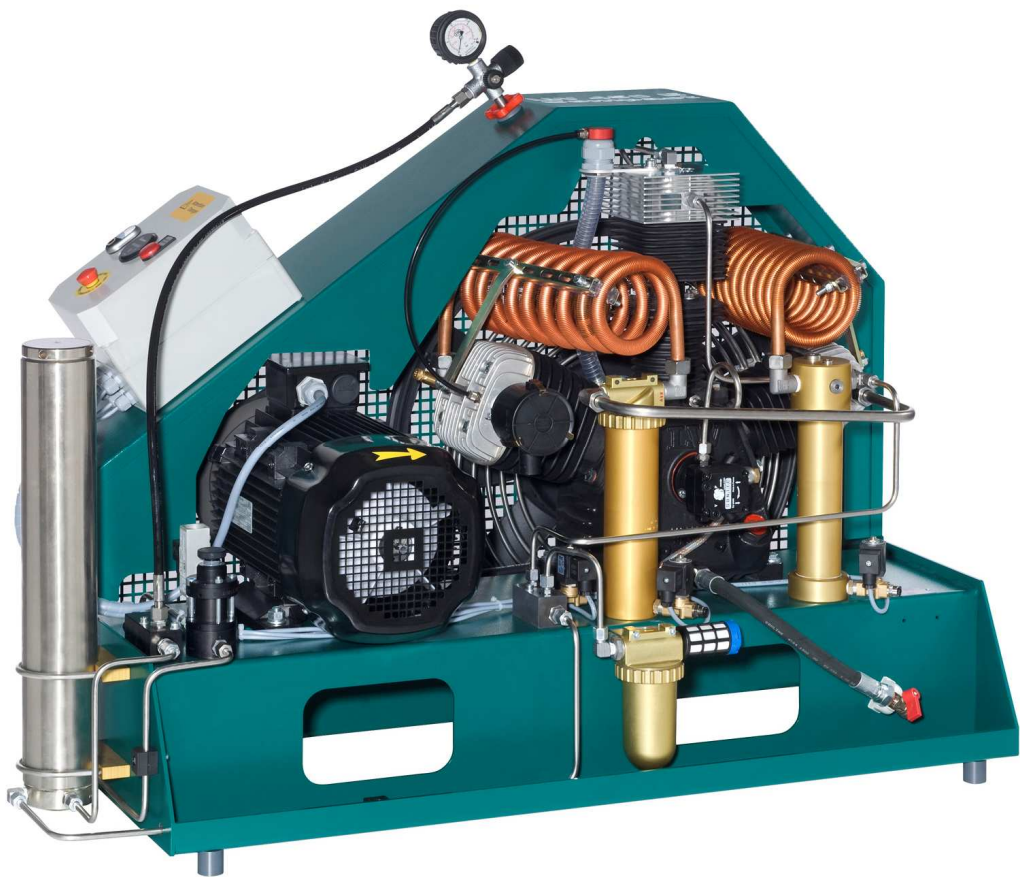



TABLE OF CONTENTS

General Information and Technical Data

| | |
|--|---|
| General Information / Description of Warning Symbols | 4 |
| Scope of Delivery | 5 |
| Technical Data | 6 |
| Unit Assembly | 7 |
| Switchboard | 8 |
| Flow chart | 9 |

Safety Precautions

| | |
|--|----|
| Intended Use / Operators | 11 |
| Safety instructions on the unit | 12 |
| General Safety Precautions | 13 |
| Unit customised safety notices | 14 |
| Maintenance instructions | 15 |
| Transportation instructions / Safety regulations | 16 |

Installation

| | |
|------------------------------------|---------|
| Installation in closed rooms | 18 |
| Dimensions | 19 |
| Minimum distances | 20 |
| Ventilation | 21 |
| Electrical Installation | 22 - 23 |

Operation

| | |
|--|---------|
| Important operation instructions | 25 |
| First commissioning | 26 - 28 |
| Daily commissioning | 29 |
| Filling procedure | 30 |
| Switch off the compressor | 31 |

| | |
|-------------------------------|---------|
| Remedying faults | 32 - 36 |
|-------------------------------|---------|

Maintenance and Service

| | |
|---|---------|
| Service, Repair and Maintenance | 38 |
| Maintenance Lists / Maintenance Intervals | 39 - 42 |
| Service Kits | 43 |
| Check V-belt tension / Tension V-belt | 44 |
| Compressor lubrication / Check oil level | 45 |
| Oil change | 46 |
| Oil sieve change | 47 |

A



TABLE OF CONTENTS

Maintenance and Service

| | |
|---|---------|
| Automatic condensation dump system | 48 |
| Oil / water separator 1st stage - maintenance | 49 - 50 |
| Oil / water separators 2nd stage - maintenance | 51 - 52 |
| Filter housing 1.7ltr / 0.8ltr | 53 |
| 1.7ltr filter cartridge change | 54 |
| 1.7ltr filter housing - maintenance | 55 |
| Inlet filter / Inlet filter cartridge change | 56 |
| Cylinder heads and valves | 57 |
| Replace inlet and outlet valves 1st and 2nd stage | 58 - 59 |
| Replace inlet and outlet valve 3rd stage | 60 |
| Replace piston rings and needle bearings of the 2nd and 3rd stage | 61 - 62 |
| Safety valves | 63 |
| Pressure maintaining / non return valve | 64 |
| Safety valve test | 65 |
| Leak test | 66 |
| Pressure gas vessel test | 67 |
| Maintenance records | 69 - 73 |

Storage

| | |
|--|----|
| Conservation / storage of the compressor | 74 |
| De-conservation, commissioning | 74 |
| Transportation instructions / Disposal | 75 |

A

GENERAL INFORMATION

General Information

We strongly recommend reading this manual thoroughly prior to operation and follow all the safety precautions precisely. Damage resulting from any deviation from these instructions is excluded from warranty and liability for this product. Carry out other commissioning steps only if you have fully understood the following contents.

Before commissioning and using the unit, carry out all the essential preliminary work and measures concerning legal regulations and safety. These are described on the following pages of this operation manual.

A

Description of marks and warning signs

The following warning signs are used in this document to identify the corresponding warning notes which require particular attention by the user. The warning signs are defined as follows:



Caution

Indicates an imminently hazardous situation which, if not avoided, could result in serious injury, physical injury or death.



Warning

Indicates a potentially hazardous situation which, if not avoided, could result in physical injury or damage to the product or environment.



Note

Indicates additional information on how to use the unit.



DESCRIPTION

Scope of Delivery

Compressors are provided in different equipped versions.

A

Versions

Filling pressure versions:

- PN 225 bar
- PN 330 bar
- PN 225 / 330 bar

Specifications

- Painted steel frame and V-belt guard (RAL 6026)
- Hour counter
- Start/ Stop and emergency stop switch
- Manual condensate drain
- 1 filling hose c/w filling valve
- Motor protection switch
- Pressure maintaining and non-return valve
- All pistons c/w steel piston rings
- Low pressure oil pump and filter
- Oil / water separators after each stage
- Safety valves after each stage
- 3 concentric suction/pressure valves

Options

- Automatic dump system
- Automatic stop at final pressure
- Auto start system
- Up to 3 extra filling hoses
- 200 and 300 bar parallel filling operation
- Oil pressure gauge and intermediate pressure gauge
- Oil pressure monitoring c/w auto shut down
- Cylinder head temperature monitoring with auto shut down
- Puracon filter monitoring
- Direction of rotation monitoring
- Power cable and plug

DESCRIPTION

Technical Data



| Technical Data | LW 300 E III | LW 450 E III |
|--|--------------------------------|--------------------------------|
| Capacity [l/min]: | 300 | 450 |
| Max. Operating Pressure [bar]: | 350 | 350 |
| RPM [min ⁻¹]: | 730 | 1,100 |
| Number of Pressure Stages: | 3 | 3 |
| Cylinder Bore 1st Stage [mm]: | Ø 95 | Ø 95 |
| Cylinder Bore 2nd Stage [mm]: | Ø 42 | Ø 42 |
| Cylinder Bore 3rd Stage [mm]: | Ø 18 | Ø 18 |
| Medium: | Compressed Air / Breathing Air | Compressed Air / Breathing Air |
| Intake Pressure: | atmospheric | atmospheric |
| Oil Pressure (at operating temperature) [bar]: | +1.5 (-0,2) | +1.5 (-0,2) |
| Oil Capacity [l]: | 2.7 | 2.7 |
| Intake Temperature [°C]: | 0 < +45 | 0 < +45 |
| Ambient Temperature [°C]: | +5 < +45 | +5 < +45 |
| Cooling Air Volume [m ³ /h]: | > 2,250 | > 3,300 |
| Voltage: | 400 V / 3 phase / 50 Hz | 400 V / 3 phase / 50 Hz |
| Protection Class Drive Motor: | IP 54 | IP 54 |
| Drive Power [kW]: | 7.5 | 11 |
| RPM Motor [min ⁻¹]: | 2,890 | 2,890 |
| Start: | Star/Delta | Star/Delta |
| Noise level [dB(A)]: | 82 from a distance of 1 m | 83 from a distance of 1 m |
| Dimensions W x D x H [mm]: | 1335 x 705 x 910 | 1335 x 705 x 910 |
| Weight [kg]: | ca. 365 | ca. 365 |
| Content Volume Filter housing [l]: | 1.7 | 1.7 |
| Content Volume Filter Housing (Option) [l]: | 0.8 | 0.8 |

DESCRIPTION

Unit Assembly

A

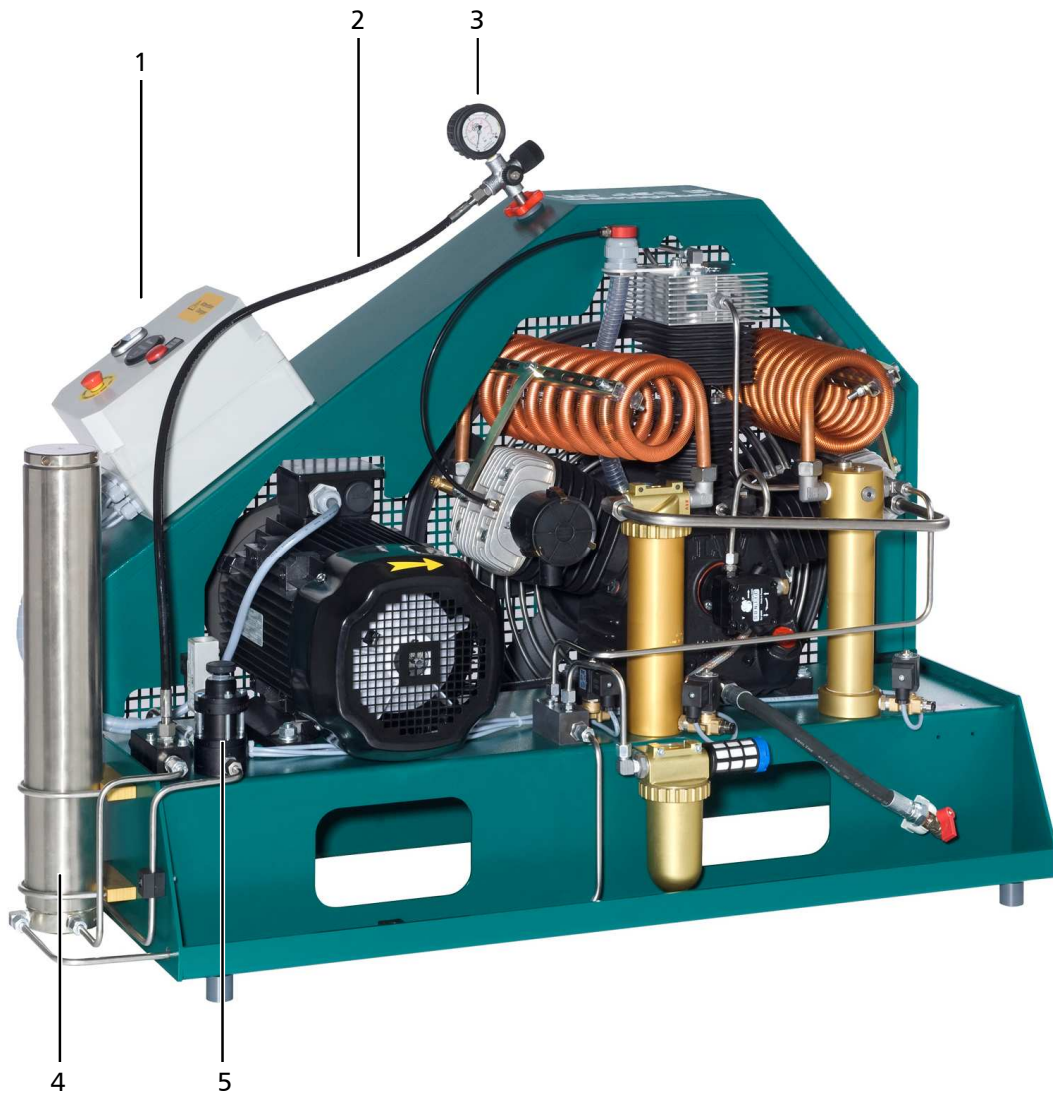

| No. | Designation |
|-----|-----------------------------------|
| 1 | Switch box |
| 2 | Filling hose |
| 3 | Filling valve with pressure gauge |
| 4 | Filter housing 1.7 litres |
| 5 | Final pressure safety valve |

DESCRIPTION

Switchboard

A

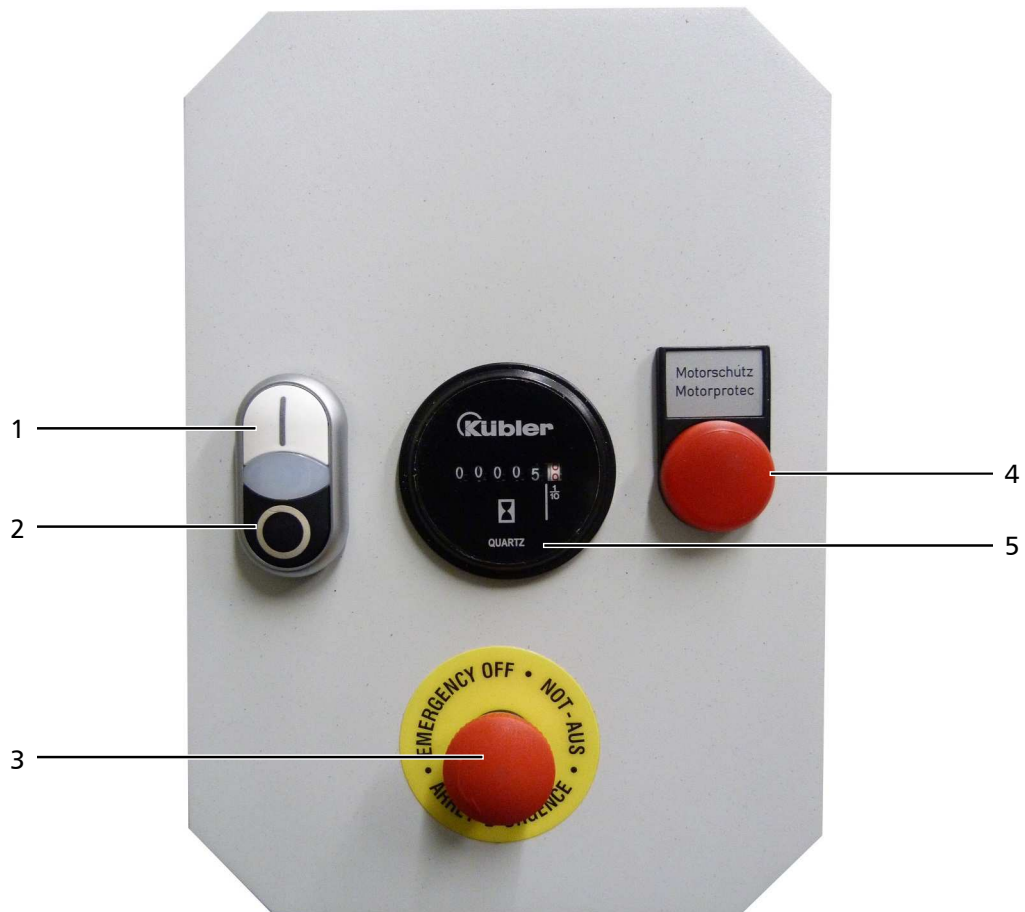

| No. | Designation |
|-----|--------------------------------|
| 1 | ON button |
| 2 | OFF button |
| 3 | Emergency shut-off switch |
| 4 | Motor protection warning light |
| 5 | Hour counter |

DESCRIPTION

Flow chart

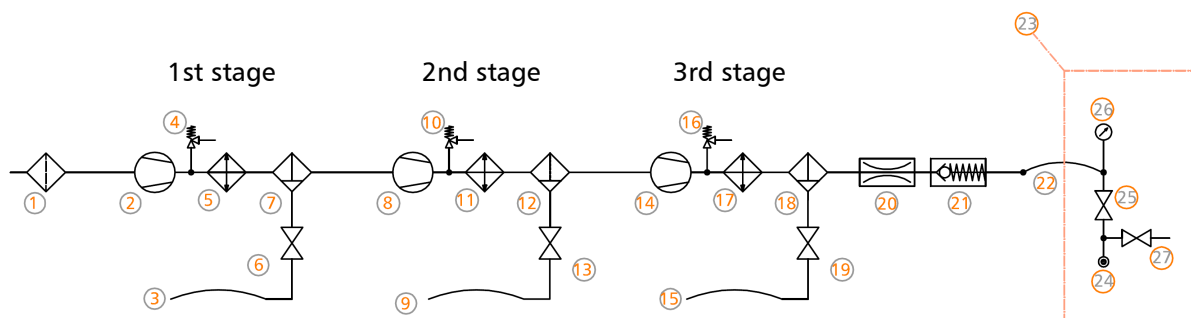

- | | |
|---|--|
| 1. Ansaugfilter / Intake Filter | 16. Sicherheitsventil 3. Stufe / Safety Valve 3rd Stage |
| 2. 1. Verdichterstufe / 1st Pressure Stage | 17. Wärmetauscher / Heat Exchanger |
| 3. Kondensat-Ablassschlauch / Condensate Drain Hose | 18. Öl- / Wasserabscheider / Oil- / Water Separator |
| 4. Sicherheitsventil 1. Stufe / Safety Valve 1st Stage | 19. Kondensat-Ablassventil / Condensate Release Valve |
| 5. Wärmetauscher / Heat Exchanger | 20. Druckhalteventil / Pressure Maintaining Valve |
| 6. Kondensat-Ablassventil / Condensate Release Valve | 21. Rückschlagventil / Non-Return Valve |
| 7. Öl- / Wasserabscheider / Oil- / Water Separator | 22. Hochdruckschlauch / HP-Hose |
| 8. 2. Verdichterstufe / 2nd Pressure Stage | 23. Baueinheit Füllventil / Filling Valve Unit |
| 9. Kondensat-Ablassschlauch / Condensate Drain Hose | 24. Flaschenanschlussstutzen / Tank Connector (DIN, CGA or INT Yoke) |
| 10. Sicherheitsventil 2. Stufe / Safety Valve 2nd Stage | 25. Füllventil / Filling Valve |
| 11. Wärmetauscher / Heat Exchanger | 26. Fülldruckmanometer / Pressure Gauge |
| 12. Öl- / Wasserabscheider / Oil- / Water Separator | 27. Entlüftungsventil / Vent Valve) |
| 13. Kondensat-Ablassventil / Condensate Release Valve | |
| 14. 3. Verdichterstufe / 3rd Pressure Stage | |
| 15. Kondensat-Ablassschlauch / Condensate Drain Hose | |



A

SAFETY PRECAUTIONS



SAFETY PRECAUTIONS

Intended Use

Only use the unit in perfect condition for its intended purpose, safety and intended use and observe the operating instructions! In particular disorders that may affect safety have to be eliminated immediately!

Use the unit exclusively for the determined medium (see "Technical Data"). Any other use that is not specified is not authorized. The manufacturer/supplier shall not be liable for any damages resulting from such use. Such risk lies entirely with the user. Authorization for use is also under the condition that the instruction manual is complied with and inspection and maintenance requirements are enforced.

No change and modification to the unit can be made without the written agreement of the manufacturer. The manufacturer is not liable for damage to persons or property resulting from unauthorized modifications.

Operators

Target groups in these instructions;

Operators

Operators are persons who are authorized and briefed for the use of the compressor.

Qualified personnel

Qualified personnel are persons who are entitled to repair, service, modify and maintain the system.



Warning

Only trained personnel are permitted to work on the unit!



Warning

Work on the electrical equipment on / with the machine / unit may only be carried out by qualified electricians.

SAFETY PRECAUTIONS

Safety instructions on the unit

Importance of notes and warning signs that are affixed to the compressor according to the application or its equipment.

A



Warning
High voltage!

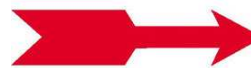

Note
Ensure correct direction of rotation!



SAFETY PRECAUTIONS

General Safety Precautions

- Read the Operating Instructions of this product carefully prior to use.
- Strictly follow the instructions. The user must fully understand and strictly observe the instructions. Use the product only for the purposes specified in the intended use section of this document.
- Do not dispose the operating instructions. Ensure that they are retained and appropriately used by the product user.
- Only trained and competent personnel are permitted to use this product.
- Comply with all local and national rules and regulations associated with this product.
- Only trained and competent personnel are permitted to inspect, repair and service the product.
- Only authentic L&W parts and accessories may be used for maintenance work. Otherwise, the proper functioning of the product may be impaired.
- Do not use faulty or incomplete products. Do not modify the product.
- Inform L&W in the event of any product or component fault or failure.
- The quality of the air supply must meet EN 12021 specifications for breathing air.
- Do not use the product in areas prone to explosion or in the presence of flammable gases. The product is not designed for these applications. An explosion might be the result if certain conditions apply.

A

SAFETY PRECAUTIONS

Unit customised safety notices

Organisational measures

- In addition to the instruction manual, observe and comply with universally valid legal and other obligatory regulations regarding accident prevention and environment protection.
- In addition to the instruction manual, provide supplementary instructions for supervision and monitoring duties taking into consideration exceptional factors e.g. with regard to organisation of work, production, personnel employed.
- Supervise personnel's work in accordance with the instruction manual, taking into account safety and danger factors.
- Observe all safety and danger notices on the compressor and check readability and completeness.

Safety instructions operation

- Take measures to ensure that the machine is only taken into operation under safe and functional conditions. Only operate the compressor if all protective and safety equipment, e.g. detachable protective equipment, are provided and in good working order.
- Check the compressor at least once per day for obvious damage and defects. Inform the responsible department / person immediately if anything is not as it should be (including operation performance). Shut down the machine immediately if necessary and lock it.
- In case of malfunction, stop the compressor immediately and lock it. Repair malfunctions immediately.
- If there is a failure in the electric energy supply, shut the machine / unit down immediately.
- Ensure safe and environmentally friendly disposal of consumables and old parts.
- The stipulated hearing protectors must be worn.
- Soundproofing equipment on the compressor has to be activated in safety function during operation.
- When handling with fats, oils and other chemical agents, observe the note for the product-related safety.



SAFETY PRECAUTIONS

Maintenance instructions

- Hoses have to be checked by the operator (pressure and visual inspection) at reasonable intervals, even if no safety-related defects have been detected.
- Immediately repair any damage. Escaping compressed air can cause injury.
- Depressurise system and pressure lines before beginning repair work.
- Pressurised air lines must be laid and mounted by qualified personnel. Connections must not be mixed up. Fittings, length and quality of the piping must correspond to requirements.
- Adjustment, maintenance and inspection activities and keep appointments, including information on replacement parts / equipment, prescribed in the operating instructions have to be respected.
- If the machine / equipment is completely off during maintenance and repair work, it must be protected against unexpected restart. Turn off main control device and remove the key and/or display a warning sign on the main switch.
- The machine and especially the connections and fittings should be cleaned from oil, fuel and maintenance products at the beginning of the maintenance / repair. Do not use aggressive cleaning agents. Use fibre-free cleaning cloths.
- Switch off compressor and clean with a slightly damp cloth. Remove dirt from cooling pipes by using a brush.
- After cleaning, examine all pipes for leaks, loose connections, chafing and damage. Immediately eliminate any faults.
- Always retighten any screw connections loosened for maintenance or repair work.
- If it is necessary to remove safety devices for maintenance and repair work, these must be replaced and checked immediately after completion of the maintenance or repair work.
- The electrical equipment of the compressor must be regularly checked. Defects, such as loose screw connections or burnt wires, must be immediately rectified by electrically skilled personnel.
- Only personnel with particular knowledge and experience with pneumatics may carry out work on pneumatic equipment.
- Only personnel with particular knowledge and experience in gas equipment may carry out work on gas equipment.

A



SAFETY PRECAUTIONS

Transportation instructions

- Parts which need to be dismantled for transport purposes must be carefully replaced and secured before taking into operation.
- The transport may only be carried out by trained personnel.
- For transportation, only use lifting devices and equipment with sufficient lifting power.
- Do not stand or work under suspended loads.
- Also separate from minor relocation machinery / system of any external energy supply. Before recommissioning, reconnect the machine to the mains according to regulations.
- When recommissioning, proceed according to the operating instructions..

Safety regulations

- Inspections according to legal and local obligatory regulations regarding accident prevention are carried out by the manufacturer or by authorised expert personnel. No guarantees whatsoever are valid for damage caused or favoured by the non-consideration of these directions for use.

A



A

INSTALLATION

INSTALLATION

Installation in closed rooms



Danger

No operation in explosion-hazard areas.

The unit is not approved for operation in areas prone to explosion.

For installation in closed rooms, observe the following:

- Install the unit horizontally and level. The floor must be vibration-free and capable of taking the load of the system weight.
- The compressor room must be clean, dry, dust free and as cool as possible. Avoid direct exposure to sunlight. If possible, install unit in such a manner that the compressor fan can intake fresh air from outside. Ensure adequate ventilation and exhaust air opening.
- When locating the compressor in rooms of less than 30 m³ space where natural ventilation is not ensured or other systems having high radiation are operating in the same room, measures must be taken to provide artificial ventilation.
- Intake air must be free from noxious gas e.g. smoke, solvent vapours, exhaust fumes etc.
- Observe the specified operating temperature (see "Technical Data")!



Note

The intake air must be free of harmful gases.

We recommend to use an intake hose in order to get fresh air from the outside.

Benchmarks - Diameter of the suction hose as a function of the suction hose length

| Pos. | Length of suction hose [m] | Diameter suction hose [mm] |
|------|----------------------------|----------------------------|
| 1 | ≤ 3 | Ø 30 |
| 2 | ≤ 10 | Ø 80 |
| 3 | ≤ 15 | Ø 100 |
| 4 | ≤ 20 | Ø 120 |

INSTALLATION

Dimensions

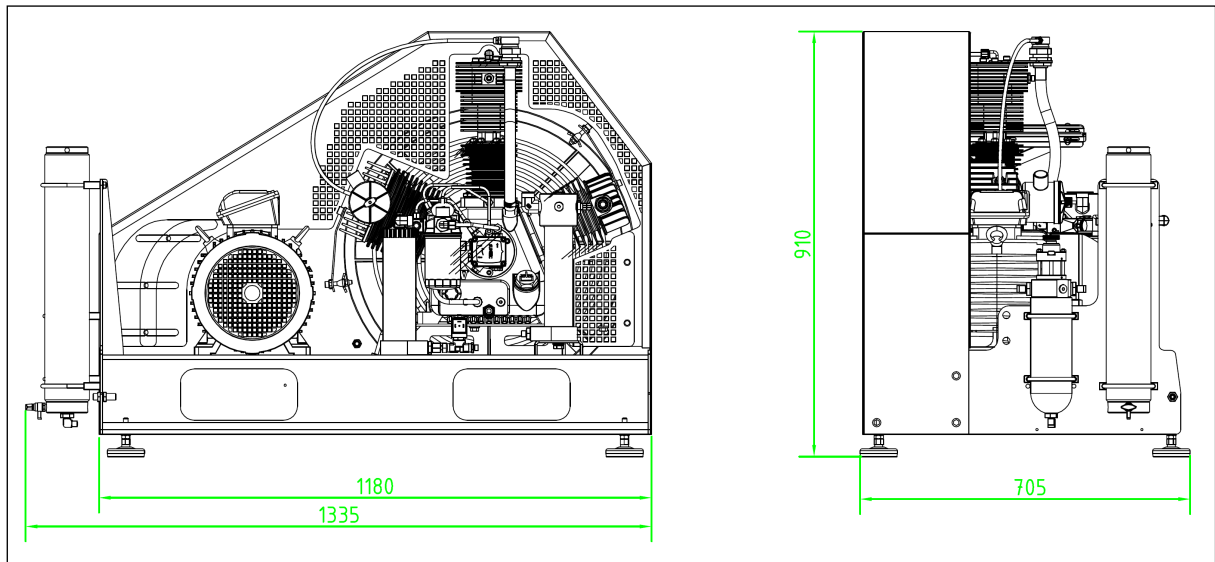

Fig. Dimensions

INSTALLATION

Minimum distances



Note

Minimum distances must be adhered!

- Make sure that the compressor always has a sufficient amount of fresh air available.
- To prevent serious damage, ensure that the cooling air flow can flow freely.
- The following minimum distances must be adhered:
Front side min. 1500 mm, sides min. 500 mm, rear side min. 500 mm.
Avoid anything in this area which can restrict the cooling air flow.

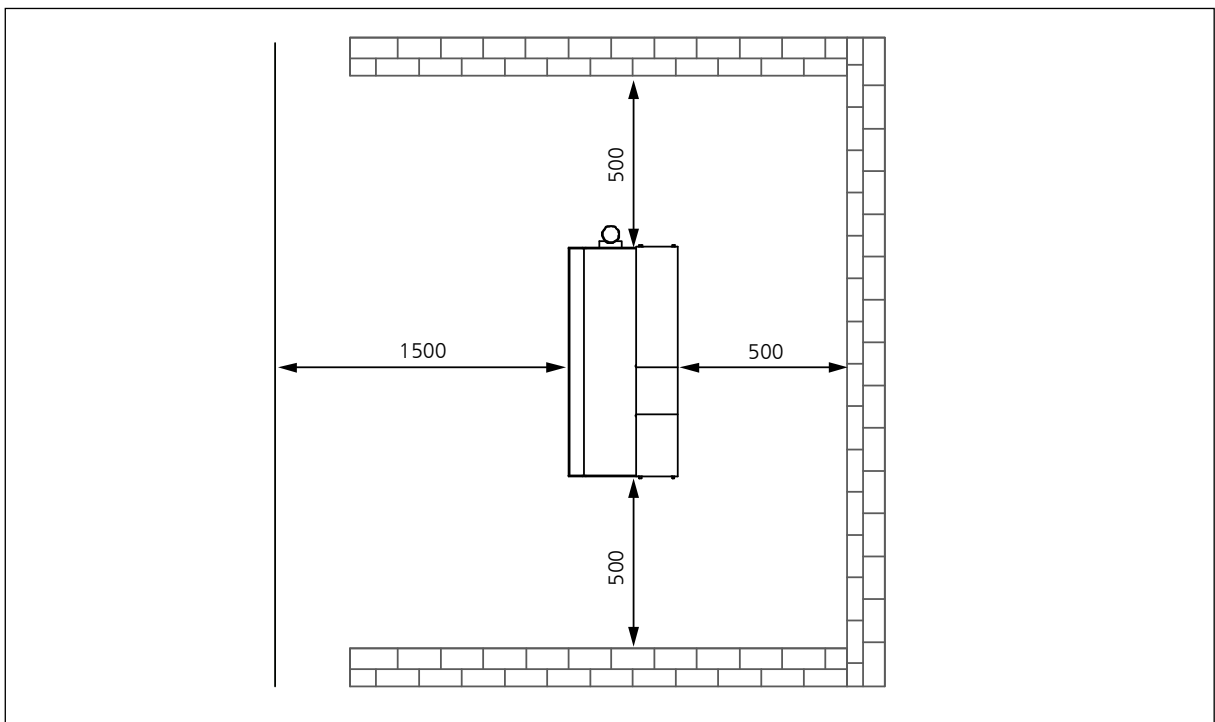

Fig. Minimum distances

INSTALLATION

Ventilation

- Make sure that the compressor always has a sufficient amount of fresh air available for cooling.
- To prevent serious damage, ensure that the cooling air flow can flow freely.
- The necessary cooling air flow can be calculated by using the following formula:
 $300 \times \text{drive power [kW]} = \text{required cooling air flow [m}^3/\text{h]}$
 Example 11kW motor: $300 \times 11\text{kW} = 3300 \text{ m}^3/\text{h} = \text{required cooling air flow.}$
- The fan capacity for fresh air and warm air must meet at least the required cooling air flow.
 The fans must have the same capacity.

A

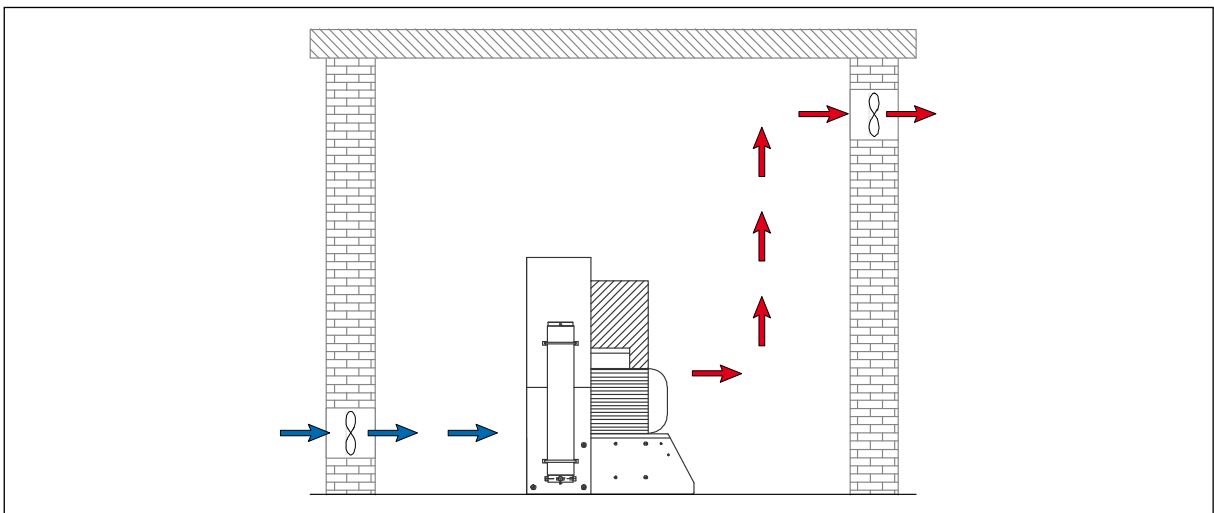

Fig. Ventilation through facade

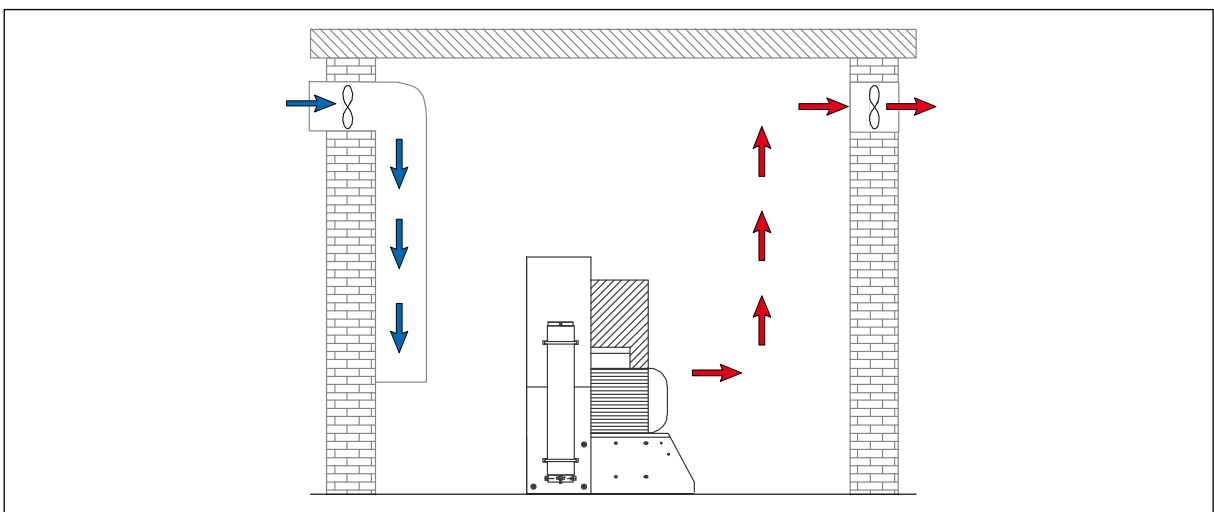

Fig. Ventilation via ventilation stack

INSTALLATION

Electrical Installation



Warning

Work on the electrical equipment on / with the machine / unit may only be carried out by qualified electricians.

For installation of electrical equipment, observe the following:

- If control devices are delivered by the factory, refer to the appropriate wiring diagram.
- Ensure correct installation of protective conductors.
- Check conformity of motor and control device tension and frequency with those of the electric network (see name plate on the compressor).
- The fusing should be done in accordance with the valid regulations of the responsible electricity supply company.
- When connecting the unit to the electrical supply, check the compressor direction of rotation (see chapter "Maintenance" -> Check turning direction).
- Fuse the motor correctly (see table; use slow-blow fuses).

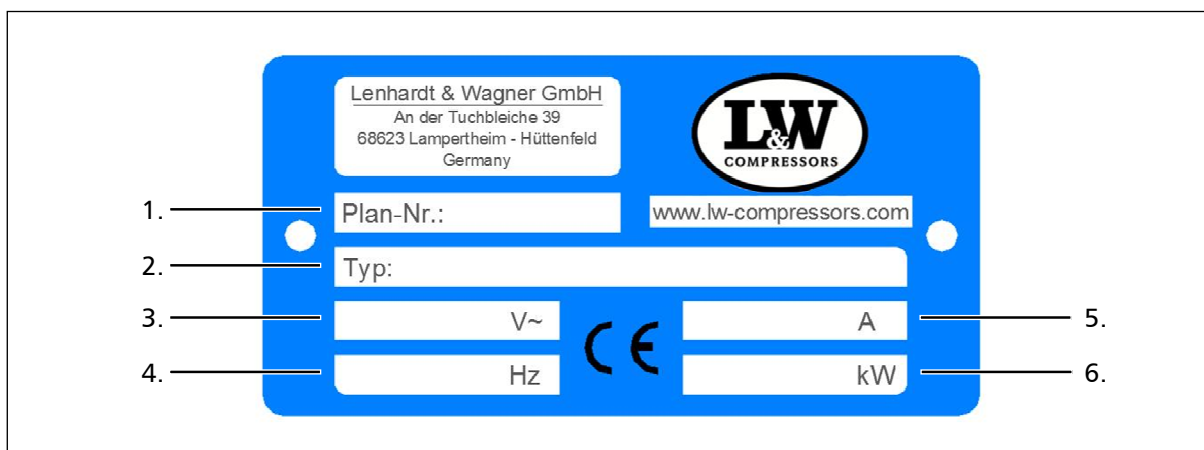

Fig. Compressor name plate

| No. | Designation |
|-----|---------------------------|
| 1. | Circuit diagram number |
| 2. | Compressor type |
| 3. | Power supply |
| 4. | Frequency |
| 5. | Motor current consumption |
| 6. | Nominal motor power |

INSTALLATION

Electrical Installation

The standard compressor version is prepared for the connection to three phases (brown, black, grey), neutral conductor (blue) and protective earth conductor (green/yellow).

Fig. - Connection to the switch box

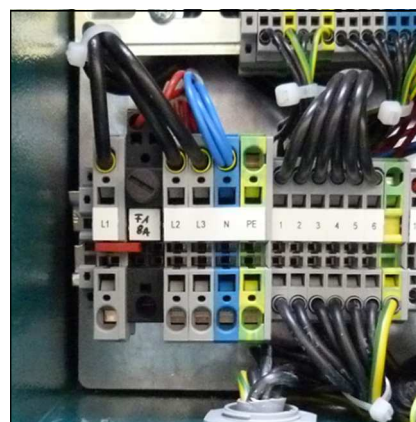

A

Recommended fuses for 360 - 500 V operating voltage

| Nominal motor power | | Fusing start A | | Connection in mm ² | |
|---------------------|------|----------------|------------|-------------------------------|-----------|
| [kw] | [A] | Direct | Star/Delta | Contactor supply | Motor S/D |
| 2.2 | 5 | 10 | - | 1.5 | 1.5 |
| 4 | 8.5 | 20 | - | 2.5 | 1.5 |
| 5.5 | 11.3 | 25 | 20 | 2.5 | 1.5 |
| 7.5 | 15.2 | 30 | 25 | 2.5 | 1.5 |
| 11 | 21.7 | - | 35 | 4 | 2.5 |
| 15 | 29.9 | - | 35 | 6 | 4 |
| 18.5 | 36 | - | 50 | 6 | 4 |
| 22 | 41 | - | 50 | 10 | 4 |
| 30 | 55 | - | 63 | 10 | 6 |

Recommended fuses for 220 - 240 V operating voltage

| Nominal motor power | | Fusing start A | | Connection in mm ² | |
|---------------------|------|----------------|------------|-------------------------------|-----------|
| [kw] | [A] | Direct | Star/Delta | Contactor supply | Motor S/D |
| 2.2 | 8.7 | 20 | - | 1.5 | 1.5 |
| 4 | 14.8 | 25 | - | 2.5 | 1.5 |
| 5.5 | 19.6 | 35 | 25 | 4 | 2.5 |
| 7.5 | 26.4 | 50 | 35 | 6 | 4 |
| 11 | 38 | - | 50 | 6 | 4 |
| 15 | 51 | - | 63 | 10 | 4 |
| 18.5 | 63 | - | 80 | 16 | 6 |
| 22 | 71 | - | 80 | 16 | 6 |
| 30 | 96 | - | 125 | 25 | 10 |



A

OPERATION



OPERATION

Important operation instructions



Note

Ensure that all persons handling the compressor are familiar with function and operation of the unit.



Wear hearing protection

When working on a running machine, always wear hearing protection.

A

FIRST COMMISSIONING

A

Prior to first commissioning, observe the following:

Necessary steps are described on the next page.

- Ensure that cooling air can flow freely.
- Check compressor oil level by the oil sight glass (see next page).
- Check all connections and retighten if necessary.
- Check if the filter cartridge is in place (see "Service and Maintenance").
- Check the V-belt tension (see next page).
- Check if all filling valves are closed. Open one filling valve and hold tight manually!

Start the compressor

1. Start the compressor by pushing the ON button.
2. Check turning direction - see the rotary direction arrow on the housing of the electric motor (see next pages). If the turning direction is wrong, immediately stop the compressor by pushing the OFF button and contact an authorised electrician.



Warning

Wrong impeller rotation direction!

Immediately after switching the compressor on, check the rotation direction. Depending on the place of installation, the phase sequence can influence the rotation direction.

3. Check oil pressure (if oil pressure gauge is installed).
4. Run the compressor for about 2 minutes.
5. Close the open filling valve carefully.
6. Run the compressor up to maximum pressure and check if the final pressure switch shuts off the compressor. If the final pressure switch does not shut off, switch off the compressor with the OFF button (see chapter "REMEDYING FAULTS").
7. Check the compressor unit for leaks (see "SERVICE AND MAINTENANCE")
8. Now check the condensate drain valves:
 - Fix the black condensate hoses
 - Drain test - press the test button
 - If correct, air escapes
9. Stop the compressor by pushing the OFF button.
10. Open all filling valves carefully to vent.

FIRST COMMISSIONING

Check oil level



Warning

Check oil level daily. Never start the compressor with a too low oil level. Risk of accidental loss, destruction or deterioration.

Check oil before each operation of the system!

The oil level should be between the middle and upper end of the oil sight glass. Never start the compressor with a too low oil level.

Refill new compressor oil at least when the oil level reached the middle of the indicated area.

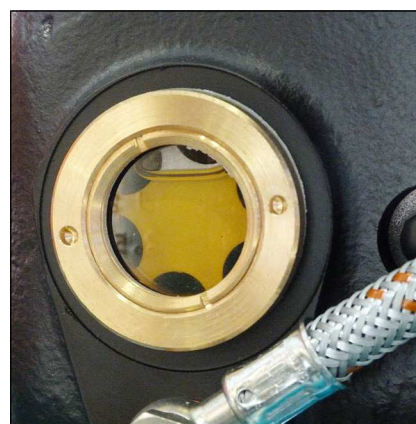

Oil sight glass

Check V-belt tension

The V-belt could lose tension during transportation. Please check the V-belt tension before starting the compressor.

Tension V-belt

To tighten V-belt tension, loosen 4 mounting nuts of the drive motor. Use the tensioning screw to move the electric motor until the V-belt tension is sufficient. Then, tighten mounting nuts and check V-belt tension.

We recommend using a V-belt tension gauge.

Correct V-belt tension

Do not tension V-belt too tight. This damages bearings of compressor and motor. The V-belt should only be tensioned until there is no noise caused by slipping during start.

Settings

| Motor Type | Initial Installation | Operation after running in |
|----------------------|----------------------|----------------------------|
| Electric motors 50Hz | 600 N | 450 N |
| Electric motors 60Hz | 500 N | 400 N |

FIRST COMMISSIONING

Check turning direction



Warning

Wrong impeller rotation direction!

Immediately after switching the compressor on, check rotation direction. Depending on the place of installation, the phase sequence can influence the rotation direction.

Before starting the compressor for the first time, check rotation direction (see the rotary direction arrow on the housing of the electric motor).

If the direction of rotation is wrong, the guide pistons of the 2nd and 3rd stages can not be sufficiently lubricated, with the consequence that the pistons will be damaged. Furthermore, cooling air flow will not be sufficient.

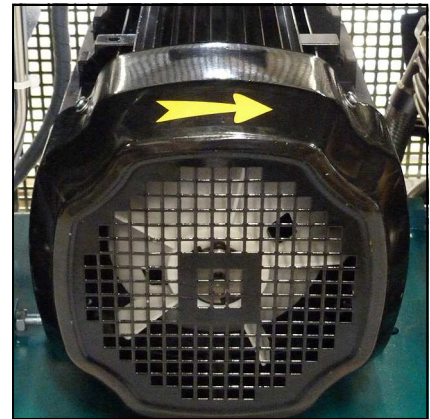

Rotation direction arrow

A



DAILY COMMISSIONING

Prior to daily operation observe the following:

- Ensure cooling air can flow freely.
- Check compressor oil level by the oil sight glass.
- Check if filter cartridge is in place / observe filter cartridge life!
- Ensure toxic-free, pure intake air.

A

OPERATION

Filling procedure



Caution! Fill only cylinders which:

- are marked with the test mark and the test stamp of the expert.
- have been hydrostatic tested (check last test date).
- are rated for the final pressure.
- are free from humidity.



Note

The unit shuts down when final pressure is reached. Thus, the unit always has to be restarted manually.

1. Close all filling valves.
2. Connect the closed compressed air cylinders.
3. Open cylinder valves.
4. Start compressor by pushing the ON button.
5. When the filling pressure gauge increases, open the filling valves slowly.
6. Fill compressed air cylinders to the desired pressure, subsequently close the filling valves slowly.
7. Close and vent all filling valves.
8. Disconnect all compressed air cylinders from filling valves.

A

OPERATION

Switch off the compressor

The compressor unit is equipped as standard with a pressure switch which automatically shuts down the system when the corresponding final pressure is reached.

During filling process, you can shut down the system at any time by pushing the red button (OFF) or the emergency stop (only in case of emergency!).



Note

After automatic or manual switching off, all pressure vessels and filter housings of the compressor will be automatically vented.



A

REMEDYING FAULTS

REMEDYING FAULTS

A

Final pressure can not be reached

| Cause of fault | Remedy |
|---|---|
| Connections leaky | Retighten or clean/replace if necessary |
| Final pressure safety valve leaky | Replace |
| Pipes / heat exchanger broken | Replace |
| Condensate drain valves leaky | Unscrew valves, check sealing surfaces, clean, replace if necessary |
| Final pressure switch stop unit | Verify settings, replace if necessary |
| Piston of pneumatic condensate valve sticks | Clean pneumatic condensate valve and restore function, check/replace o-rings, replace valve completely if necessary |

Strong compressor vibration

| Cause of fault | Remedy |
|---------------------------------------|---------------------------------|
| V-belt tension too loose | Tension V-belt |
| Drive motor / Compressor unit loosely | Retighten mounting screws |
| Anti vibration mounts used up | Replace |
| Ground not levelled | Ensure a solid and level ground |

Air supply too low

| Cause of fault | Remedy |
|--|---|
| Inlet and outlet valves contaminated / defective | Clean, replace if necessary |
| Cylinder(s), piston(s) or piston ring(s) used up | Replace |
| V-belt slips | Tension V-belt |
| See chapter "Final pressure can not be reached" | See chapter "Final pressure can not be reached" |

REMEDYING FAULTS

Compressor overheated

| Cause of fault | Remedy |
|--|--|
| Inlet filter cartridge contaminated | Replace |
| Ambient temperature too high | Improve room ventilation / |
| Cooling air inlet and outlet insufficient | Observe minimum distances (see Installation Instructions) |
| Air intake hose too long | Reduce length of the air intake hose |
| Air intake hose diameter too small | Use a larger diameter |
| Wrong compressor rotation direction | Ensure correct phase rotation, observe rotation direction arrow! |
| Inlet and outlet valves contaminated / defective | Clean, replace if necessary |

Safety valve leaks

| Cause of fault | Remedy |
|---|-----------------------------|
| Inlet and outlet valves of the following pressure stage defective | Clean, replace if necessary |
| Sinter filter of the following water separator blocked | Replace |
| Safety valve leaky | Replace |

Oil taste in the air

| Cause of fault | Remedy |
|--|----------------------------|
| Mole carbon filter cartridge saturated | Replace |
| Compressor oil unsuitable | Use prescribed oil quality |
| Filter cartridge unsuitable | Use prescribed filter type |
| Cylinder(s), piston(s) or piston ring(s) defective | Replace |

REMEDYING FAULTS

Automatic condensate drain defective

| Cause of fault | Remedy |
|---|---|
| Solenoid coils defective | Replace |
| Cable / supply cable defective | Repair, replace if necessary |
| Timer / relais defective | Replace |
| Sinter filter of pneumatic condensate valve blocked | Replace |
| Piston of pneumatic condensate valve sticks | Clean pneumatic condensate valve and restore function, check/replace o-rings, replace valve complete if necessary |

Condensate drain starts before reaching final pressure

| Cause of fault | Remedy |
|---|---|
| Pressure stages are not as prescribed, control pressure of pneumatic condensate valve too low | Check corresponding inlet and outlet valve, replace if necessary. |
| Piston sealing of pneumatic condensate valve contaminated / used up | Clean, replace if necessary |
| Timer / relais settings not correct | Adjust as prescribed |
| Timer / relais defective | Replace |

Compressor stops before final pressure

| Cause of fault | Remedy |
|---|---|
| Final pressure switch settings not correct | Correct settings |
| Opening pressure of the pressure maintaining valve too high | Correct settings |
| Fuse / circuit breaker has tripped Valid only for E models | Check fusing of the power supply / observe regulations |
| Emergency stop switch has tripped | Unlock emergency stop switch, close compressor housing door correctly |

REMEDYING FAULTS

Filter life not sufficient

| Cause of fault | Remedy |
|--|--|
| Pressure maintaining valve settings not correct | Adjust as prescribed |
| Filter cartridge unsuitable | Replace by a prescribed filter cartridge type |
| Filter cartridge too old | Observe expiration date |
| Filter cartridge packaging incorrect / damaged / already opened. Filter cartridge already partly saturated before change | Store filter cartridges properly, dispose defective cartridges |
| Operating temperature too high | Ensure sufficient ventilation |
| Cylinder(s), piston(s) or piston ring(s) defective | Replace |

Oil consumption too high

| Cause of fault | Remedy |
|--|---|
| Cylinder(s), piston(s) or piston ring(s) defective | Replace |
| Compressor oil unsuitable | Use prescribed oil quality |
| Operating temperature too high | Observe prescribed operating temperatures |
| Oil leak at the compressor block | Tighten corresponding mounting screws, if necessary replace corresponding paper sealing / o-ring / shaft seal |



A

MAINTENANCE AND SERVICE

MAINTENANCE AND SERVICE

Service, Repair and Maintenance

Carry out service and maintenance work exclusively when the compressor is stopped and depressurised. The unit should be leak-checked regularly. Leaks can be preferably localised by using a leak detector spray (if necessary, brush pipes with soapy water).

We recommend that only authorised L&W service technicians carry out service work on the bearing of the compressor (crankshaft and connecting rods).

We urgently recommend that all maintenance, repair and installation work must only be carried out by trained personnel. This is necessary because all maintenance work can not be explained exactly and detailed in this manual.

Only use authentic spare parts for service work.



Danger

Components under pressure, such as hose ends, can quickly come loose when manipulated and can cause potentially fatal injuries due to the pressure surge. Any work on system parts may only be performed in a pressure-compensated state.



Warning

The use of accessories that have not been tested can lead to death or serious injury or damage to the unit. Only use authentic spare parts for service work.



Warning

Carry out maintenance or service work when the unit is switched off and protected against unexpected restart.



Warning

Risk of burns!

Carry out maintenance or service work when the unit has cooled down.



MAINTENANCE AND SERVICE

Daily before taking unit into operation

| Maintenance work | Type | Quantity | Order No. |
|--|------|----------|-----------|
| Check oil level | - | - | 000001 |
| Check condition of all filling hoses | - | - | - |
| Check filter cartridge lifetime | - | - | - |
| Operate unit to final pressure and check function of final pressure switch | - | - | - |

At 25 operation hours

| Maintenance work | Type | Quantity | Order No. |
|------------------------------|------|----------|-----------|
| Oil change | - | 2,7 | 000001 |
| Replace Oil Filter Cartridge | - | 1 | 009446 |

Every 3 months or as required

| Maintenance work | Type | Quantity | Order No. |
|---|------|----------|-----------|
| Check/Retorque all connections and bolts | - | - | - |
| Open solenoid valve at the 1.7ltr filter housing, drain condensate if necessary | - | - | - |



MAINTENANCE AND SERVICE

Annually

| Maintenance work | Type | Quantity | Order No. |
|---|------|----------|-----------|
| Oil change, if less than 1000 operating hours | - | 2.7 | 000001 |
| Check opening pressure of final safety valve | - | - | - |
| Clean coolers | - | - | - |
| Clean all oil/water separators, if less than 500 operating hours | - | - | - |
| Service intake filter (depends on condition - if less than 500 operating hours) | - | - | - |
| Check all connections for leakage | - | - | - |

Every 500 operating hours

| Maintenance work | Type | Quantity | Order No. |
|---|------|----------|-----------|
| Change intake filter | - | 1 | 000170 |
| Check pressure maintaining/non-return valve | - | - | - |
| Check V-belt tension and condition | - | - | - |

MAINTENANCE AND SERVICE

Every 1000 operating hours

| Maintenance work | Type | Quantity | Order No. |
|--|---------------------|----------|-----------|
| Replace V-belt | LW 300 E III (50Hz) | 1 | 004101 |
| | LW 300 E III (60Hz) | 1 | 004101 |
| | LW 450 E III (50Hz) | 1 | 009975 |
| | LW 450 E III (60Hz) | 1 | 004101 |
| Replace sintered metal filter element of water separators | 1st stage | 1 | 000184 |
| | 1st stage | 1 | 002914 |
| | 2nd stage | 1 | 000173 |
| | 2nd stage | 1 | 002914 |
| Replace o-rings of water separators | 1st stage | 1 | 001294 |
| | 1st stage | 2 | 001272 |
| | 2nd stage | 3 | 001272 |
| Replace o-ring of condensate stop valve | - | 2 | 001264 |
| Replace sintered metal filter of condensate stop valve housing | - | 1 | 002914 |
| Replace o-ring of condensate stop valve housing | - | 1 | 006382 |
| Replace sintered metal filter of pneumatic condensate valve | - | 1 | 000188 |
| Replace sintered metal filter of solenoid valve (350bar) | - | 1 | 003159 |
| Replace oil sieve | - | 1 | 009545 |
| Replace oil pump cover gasket | - | 1 | 009546 |
| Replace Oil Filter Cartridge | - | 1 | 009446 |
| Oil change | - | 2.7 | 000001 |
| Replace o-rings of the filter housing 1.7ltr | - | 2 | 001287 |
| Replace back-up rings of the filter housing 1.7ltr | - | 2 | 001285 |
| Replace filter of 0.8l filter housing 0.8ltr | - | 1 | 003980 |
| Replace o-ring of the filter housing 0.8ltr | - | 1 | 004221 |
| Replace back-up ring of the filter housing 0.8ltr | - | 1 | 004222 |



MAINTENANCE AND SERVICE

Every 1000 operating hours (Latest in 10 years)

| Maintenance work | Type | Quantity | Order No. |
|---|------|----------|-----------|
| Replace filter of condensate-catch-tank | - | 1 | 006462 |
| Replace o-ring of condensate-catch-tank | - | 1 | 002152 |

Every 4000 operating hours (Latest in 10 years)

| Maintenance work | Type | Quantity | Order No. |
|---|-----------------------------------|-----------|---|
| Replace all o-rings and gaskets of 1st, 2nd and 3rd stage | O-ring | 3 | 008874 |
| | O-ring | 1 | 001274 |
| Replace all inlet and outlet valves incl. gaskets | 1st stage | 1 | 000259 |
| | 2nd stage | 1 | 000256 |
| | 3rd stage | 1 | up to compressor block no. 858: 010165 from compressor block no. 859: 010337 |
| | Upper gasket 1st | 1 | 000257 |
| | Upper gasket 2nd | 1 | 000254 |
| | Lower gasket 1st | 1 | 000258 |
| | Lower gasket 2nd | 1 | 000253 |
| | Replace needle bearing for conrod | 2nd stage | 1 |
| Replace needle bearing for conrod | 3rd stage | 1 | 003281 |

A

MAINTENANCE AND SERVICE

Service Kits

The service kits contain parts for maintenance according to the factory requirements.

The use of the service kits ensures that all required parts are ordered and replaced and gives assurance that all parts are included in the order. Depending on the model and interval, the service kits include parts such as O-Rings, Sinter Filter, Inlet Filter, V-Belts, Silencers, In-&Outlet Valve, Valve Seals and Compressor oil.



Service Kits

A

Service Kits LW 300 E / LW 450 E for 50 Hz

| Compressor | Frequency | Operating Hours | Order No. |
|--------------|-----------|-----------------|-----------|
| LW 300 E III | 50 Hz | 1000 h | 010029 |
| LW 450 E III | 50 Hz | 1000 h | 010027 |

Service Kits LW 300 E / LW 450 E for 60 Hz

| Compressor | Frequency | Operating Hours | Order No. |
|--------------|-----------|-----------------|-----------|
| LW 300 E III | 60 Hz | 1000 h | 010025 |
| LW 450 E III | 60 Hz | 1000 h | 010029 |



MAINTENANCE AND SERVICE

Check V-belt tension

The V-belt could lose tension during transportation. Please check the V-belt tension before starting the compressor.

Tension V-belt

To tighten V-belt tension, loosen 4 mounting nuts of the drive motor. Use the tensioning screw to move the electric motor until the V-belt tension is sufficient. Then, tighten mounting nuts and check V-belt tension.

We recommend using a V-belt tension gauge.

Correct V-belt tension

Do not tension V-belt too tight. This damages bearings of compressor and motor. The V-belt should only be tensioned until there is no noise caused by slipping during start.

Settings

| Motor Type | Initial Installation | Operation after running in |
|----------------------|----------------------|----------------------------|
| Electric motors 50Hz | 600 N | 450 N |
| Electric motors 60Hz | 500 N | 400 N |

MAINTENANCE AND SERVICE

Compressor lubrication

The following parts get lubricated by a mechanical oil pump (gear type, directly driven by crankshaft):

- crankshaft roller bearing (oil pump side)
- big end bearings
- guide cylinder (3rd stage)

Additional lubrication by splash oil on:

- crankshaft bearing (flywheel side)
- 1st and 2nd stage cylinders

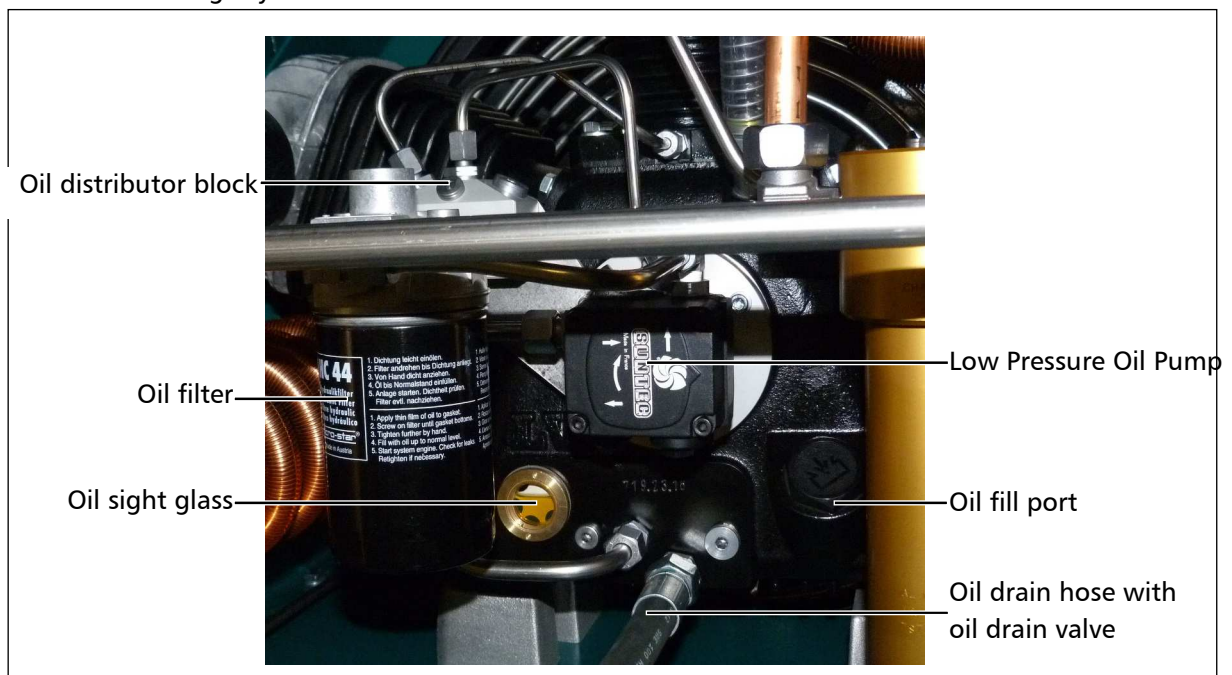

Lubricating System

Check oil level



Warning

Check oil level daily. Never start the compressor with a too low oil level. Risk of accidental loss, destruction or deterioration.

Check oil before each operation of the system!

The oil level should be between the middle and upper end of the oil sight glass. Never start the compressor with a too low oil level.

Refill new compressor oil at least when the oil level reached the middle of the indicated area.



Oil sight glass

Oil change



Note

We recommend oil change at least once a year - depending on total operating hours.

A

Oil change as follows:

- Run compressor warm for approx. 2 min.
- Switch off compressor unit, vent system and make sure it cannot be restarted.
- Place a suitable oil drain tray under the drain hose.
- Open oil drain valve and drain oil completely.
- Dismount oil filter cartridge with a filter tool (Part number: 009728).
- Fill the new oil filter cartridge with 400 ml synthetic compressor oil and mount the oil filter cartridge on the oil distribution block.
- Close oil drain valve.
- Loosen oil fill port with an appropriate adjustable wrench (AF 0-40 mm) and unscrew manually.
- Fill oil by using a funnel.
- Check oil level. The oil level should be between the middle and upper end of the oil sight glass.
- Screw oil fill port manually in and tighten with the adjustable wrench.

The oil change is now completed.

Maintenance intervals

- First oil and oil filter change after 25 operating hours (total hours).
- All further changes after each 1,000 operating hours.

Oil and oil capacity

Approx. 2,700 ml synthetic compressor oil is necessary for one oil change. Only use synthetic compressor oil which is recommended as suitable from L&W.

MAINTENANCE AND SERVICE

Oil sieve change

Oil sieve change as follows:

- Loosen cover screws (4 pcs).
- Remove the cover, the cover gasket and the oil sieve.
- Clean the oil sieve with petroleum-ether or replace the defective oil sieve.
- Replace by a new or cleaned oil sieve.
- Replace the new gaskets.
- Soak the gaskets with oil before placing (respect mounting direction).
- Remount the cover with the 4 cover screws. Tightening torque: 4.5 - 8 N.

The oil sieve change is now completed.

Maintenance intervals

- We recommend cleaning or replacing the oil sieve every 1,000 working hours.
- 009545—Oil sieve, 009546—oil pump cover gasket

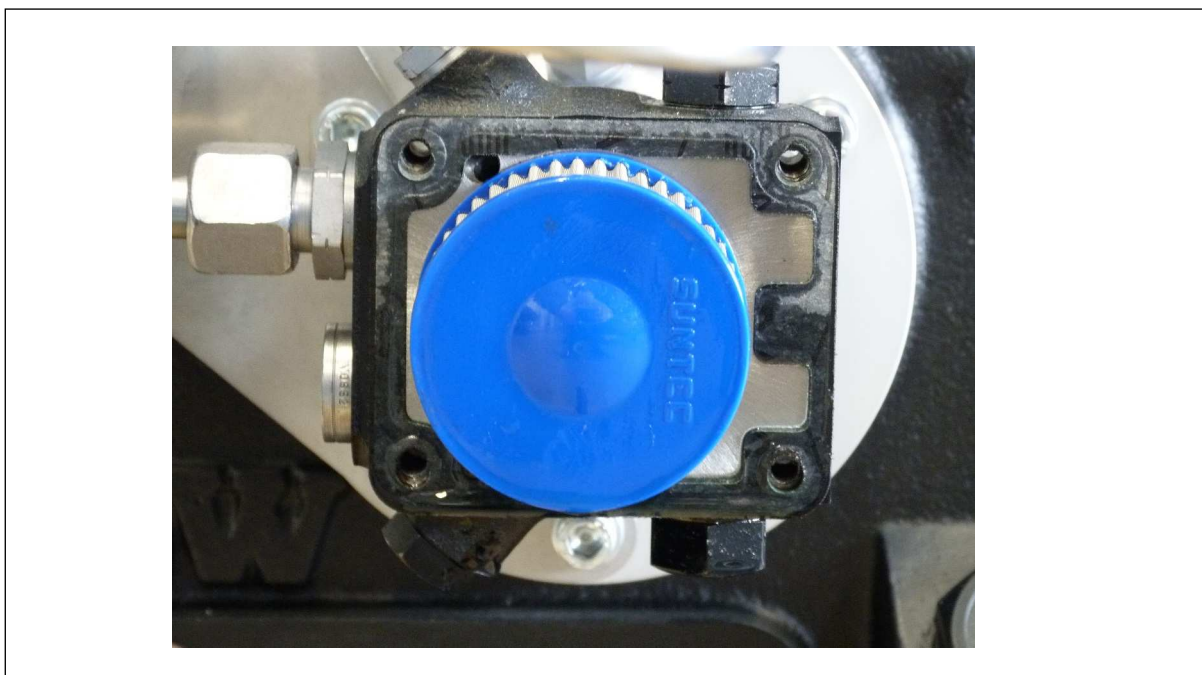

Correct cover gasket mounting direction

MAINTENANCE AND SERVICE

Manual condensation dump system



Note

The collected condensate can contain oil and has to be disposed according to regulations.

The LW 450 E Compact III comes as standard with an manual condensate drain. Drain condensate separators every 15 minutes.

To release the complete condensate through the black plastic hoses we recommend using a 20 l container at least.

The drain noise can be kept to a minimum by using a silencer.

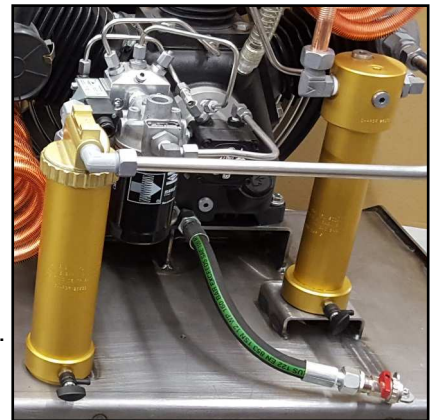

Fig. 1 Oil / water separators 1st and 2nd stage

Manual drain



Warning

Open valve spindle max. 1.5 turns.
The pressure in the housing can shoot out the valve spindles at high speed.

To drain manually, open the condensate drain valves of the 1st, 2nd and 3rd stage of the oil / water separators and the condensate drain valve of the filter housing (Fig. 2).

Open valve spindle max. 1.5 turns anti-clockwise. The condensate will be drained.

Then close valve spindle clockwise.

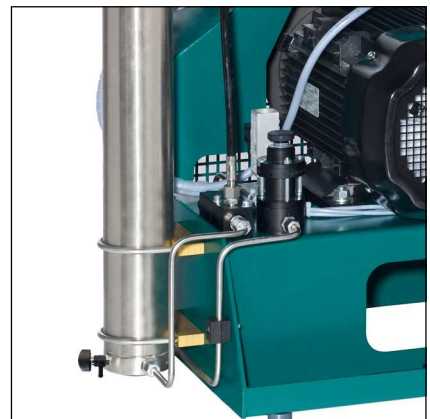

Fig. 2 - Condensate drain valve of the filter housing

Maintenance intervals

We recommend to clean oil and water separators every 500 operating hours or at least once a year, to check for corrosion damage and to replace o-rings if necessary.

All oil / water separators have an integrated sinter filter which has to be replaced every 1,000 operating hours.



Fig. 3 - Condensate drain valve

Oil / water separator 1st stage - maintenance



Note

Clean all parts thoroughly before assembly.

Change / clean oil / water separators 1st stage as follows:

- Loosen pipes and mounting screws.
- Remove oil / water separators.
- Open ring nut and remove separator top (Fig. 1).
- Open nut and remove separator top (Fig. 2).
- Change sinter filter (Fig. 3).
- Reassemble all parts and tighten nut.
- Change o-ring, previously grease new o-ring (Page 51, Fig. 4).
- Place separator top and tighten ring nut manually.
- Remove the base ring (Page 51, Fig. 5).
- Change o-rings, previously grease new o-rings (Page 51, Fig. 6).
- Remove the connection of the base ring and change the sinter filter (Page 51, Fig. 7).
- Reassemble the connection.
- Mount the base ring.
- Mount oil / water separator.
- Tighten pipes and mounting screws.

Oil / water separator maintenance is now completed.



Fig. 1 - Open ring nut and remove separator top



Fig. 2 - Loosen nut at the separator top



Fig. 3 - Change sinter filter

Oil / water separator 1st stage - maintenance - continued from previous page

A



Fig. 4 - Change o-ring



Abb. 5 - Remove the base ring



Abb. 6 - Change o-rings



Abb. 7 - Change sinter filter

MAINTENANCE AND SERVICE

Oil / water separators 2nd stage - maintenance



Note

Clean all parts thoroughly before assembly.

Maintenance / cleaning of oil / water separators 2nd stage as follows:

- Loosen pipes and mounting screws.
- Remove oil / water separators.
- Unscrew and remove filter top (Fig. 1).
- Open nut of separator top (Fig. 2).
- Change sinter filter (Fig. 3).
- Reassemble all parts and tighten nut.
- Pull the condensate stop valve out of the filter housing by using a threaded rod
- Change o-ring, previously grease new o-ring (Page 53, Fig. 4).
- Push the condensate stop valve into the filter housing by using a threaded rod.
- Change o-ring on the top of the filter housing, previously grease new o-ring (Page 53, Fig. 5).
- Place separator top and tighten manually.
- Remove the base ring (Page 53, Fig. 6).
- Change o-rings, previously grease new o-rings (Page 53, Fig. 7).
- Remove the connection of the base ring and change the sinter filter (Page 51, Fig. 8).
- Reassemble the connection.
- Mount the base ring.
- Mount oil / water separators.
- Tighten pipes and mounting screws.

The oil / water separator maintenance is now completed.



Fig. 1 - Unscrew and remove filter top



Fig. 2 - Loosen nut at the separator top



Fig. 3 - Change sinter filter

Oil / water separators 2nd stage - maintenance - continued from previous page

A



Abb. 4 - Change o-ring



Abb. 5 - Change o-ring



Abb. 6 - Remove the base ring



Abb. 7 - Change o-rings



Abb. 8 - Change sinter filter

MAINTENANCE AND SERVICE

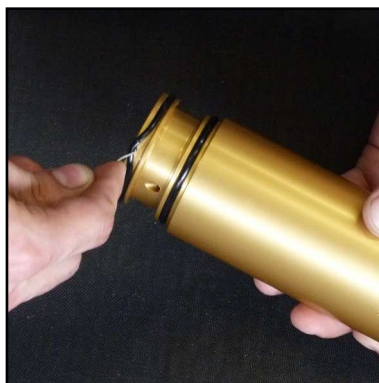
Filter housing 1.7 ltr

The mole carbon filter housing is installed on the right hand side of the compressor housing.

Inside the filter housing a jet blows air on to the housing wall. Condensation water and oil are led by centrifugal force to the bottom of the housing. Air flows through the mole carbon filter cartridge, which purifies the air from residual moisture and odours. The manual condensate drain valve needs to be opened if a drain is necessary and before filter cartridge change.

Filter cartridge 1.7 ltr

The high-pressure compressor is equipped with an integrated breathing air purification system. Air is compressed up to 330 bar, dried and odour- and tasteless purified. Oil residues are bounded. The breathing air filter cartridge consists of a molecular sieve and activated-carbon filter.

Cartridge capacity: approx. 1.7 ltr

All breathing air filter cartridges are factory vacuum sealed.

We recommend unpacking the filter cartridges just before installation. Filter cartridges which are exposed too long could be saturated with moisture and become unusable.

Maintenance intervals

The life of the 1.7 ltr filter cartridge is substantially depend on the operating temperature, from the state of wear of the compressor, of the filter size and the operating pressure.

We recommend to monitor the state of the filter.



Filterhousing 1.7l (right), and filter unit 0,8l with safety valve (left)

A

MAINTENANCE AND SERVICE

Filter cartridge change

Filter cartridge change as follows:

- Run the compressor up to a pressure of 100 bar.
- Stop compressor.
- Open filling valve.
- Unscrew filter housing cover by using the special filter tool (Fig. 1).
- Place the T-piece end of the filter tool in the recess of the filter cartridge (Fig. 2).
- Unscrew the filter cartridge anti-clockwise and pull the cartridge out of the housing (Fig. 3).
- Open the packing of the new filter cartridge and place it with the filter tool in the filter housing.
- Screw the new filter cartridge hand tight in by using the filter tool.
- Screw the cover of the filter housing first manually in.
- After it has been completely screwed in, turn cover anticlockwise for 90°. This avoids tightening of the cover due to vibration..

The filter cartridge change is now completed.



Note

Ensure that the old filter cartridge is disposed correctly at an approved waste point.



Fig. 1 - Unscrew the filter housing cover.



Fig. 2 - Place the T-piece end of the filter key in the top of the filter cartridge.



Fig. 3 - Pull the cartridge out of the housing.

A

Filter housing - maintenance



Note

Clean all parts thoroughly before assembly.

Filter housing maintenance as follows:

- Open Filter Cover (Fig. 1).
- Change o-ring and back-up ring, previously grease both (Fig. 2).
- Grease filter cover thread and close.

Dismount filter housing

- Loosen pipe connections and nuts (Fig. 3).
- Remove filter housing.
- Dismount filter housing base.
- Change o-ring and back-up ring, previously grease both (Fig. 4).
- Screw filter base tight in.

Mount filter housing

- Connect pipe connections and tighten.
- Adjust holding clamp and tighten nuts.

The filter housing maintenance is now completed.

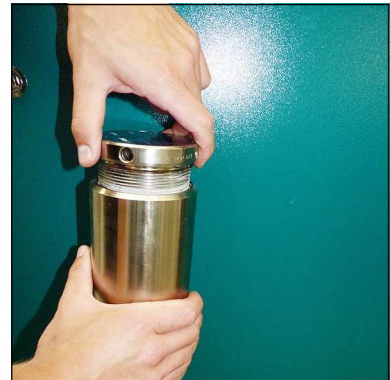

Fig. 1 - Open Filter cover

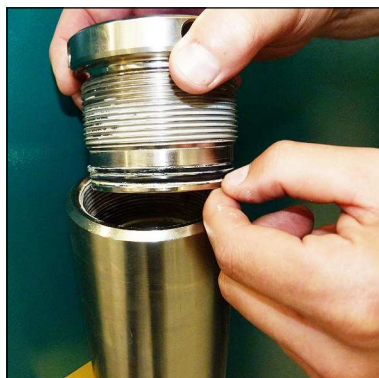

Fig. 2 - Change o-ring and back-up rings

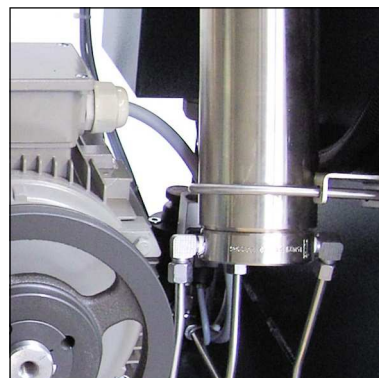

Fig. 3 - Loosen pipe connections and nuts



Fig. 4 - Change o-ring and back-up rings

Inlet Filters



Note

Dirty filters make intaking air difficult and reduce delivery capacity. Risk of compressor overheating.

A micro filter cartridge is used as an air inlet filter. Check air inlet filter regularly or replace if necessary. Defective air inlet filters should be immediately replaced.

Maintenance Intervals

We recommend that the filter cartridge should be replaced every 1,000 working hours (depending on pollution grade).

Inlet Filter Cartridge Change

Inlet filter cartridge change as follows:

- Loose nut (Fig.1)
- Remove cover and replace filter cartridge by a new one (Fig.2)
- Assemble intake filter
- Tighten nut

The inlet filter cartridge change is now completed.



(Fig.1) Loose nut

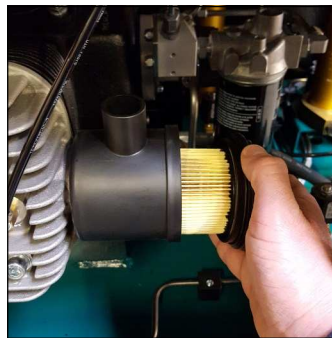

(Fig.2) Remove cover and replace filter cartridge

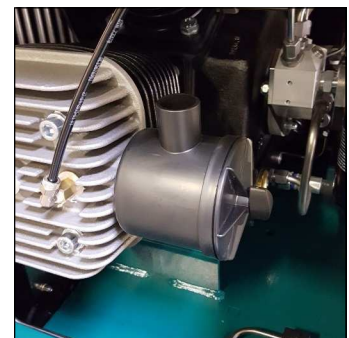

(Fig.3) Mount the intake filter

Filter cartridge inlet filter

MAINTENANCE AND SERVICE

Cylinder heads and valves

Inlet and outlet valves of the specific compressor stages are located between valve head and cylinder. Outlet valves open while piston upstroke or compression stroke, inlet valves open while downstroke.

Valves are subject to normal wear and tear and have to be replaced at certain intervals (depending on specific operating conditions). Dismount valve heads to change valves. The three valves are combined inlet and outlet valves. The first and second stage valves are plate valves. The third stage contains a spring operated piston which acts inside a bronze cylinder.



Valve head 3rd stage

A

Maintenance intervals

All valves should be replaced after 4,000 working hours due to normal wear and tear. To replace valves the cylinder heads have to be removed. There are no special tools required to replace these valves.

Available special tools

Special tools are not necessary for dismounting inlet and outlet valves but make work easier.

Order number: 006847



Special tool

Replace inlet and outlet valves 1st and 2nd stage



Note

The figures of the parts can differ due to the different stages.

Change inlet and outlet valves 1st and 2nd stage as follows:

Remove Inlet / Outlet Valve

- Loosen pipe connections
- Loosen valve head screws (Fig. 1)
- Remove valve head
- Pull out inlet and outlet valve (Fig. 2). CAUTION: Observe that the lower copper valve ring is also pulled out. (It can still stick inside the cylinder)
- Check valve head if defective

Install Inlet / Outlet Valve - see following page



Fig. 1 - Loosen valve head screws



Fig. 2 - Pull out inlet and outlet valve

Replace inlet and outlet valves 1st and 2nd stage - continued from previous page

A



Caution

The exact alignment of upper and lower valve gasket is very important. Inlet and outlet channels have to be exactly centred. Do not turn inlet and outlet valve after insertion. The copper valve ring could cover outlet channels.

Install Inlet / Outlet Valve

- Grease the lower valve gasket slightly and place on the new inlet and outlet valve.
CAUTION: Observe correct copper valve ring position (centre inlet and outlet channels).
- Place the new inlet and outlet valve straightly into the cylinder (Fig. 3).
CAUTION: Do not turn the inlet and outlet valve inside the cylinder! The copper valve ring could cover outlet channels!
- Place the upper valve gasket on the inlet and outlet valve.
CAUTION: Observe the correct paper gasket position (centre inlet and outlet channels). (Fig. 4)
Note: Valve head screws can be inserted into the valve head to secure the upper valve gasket.
- Refit the valve head and tighten the valve head screws cross-wise.

Starting torques:

1. nd Stage 45 Nm
2. nd Stage 30 Nm

The replacement inlet and outlet valves 1st and 2nd stage is now completed.

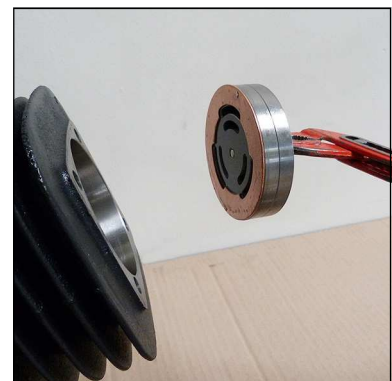

Fig. 3 - Place new inlet and outlet valve straightly into cylinder



Fig. 4 - Ensure the correct mounting position of the paper gasket

Replacement inlet and outlet valves 3rd stage

Replacement inlet and outlet valves 3rd stage as follows:

- Loosen pipe connections
- Loosen valve head screws (Fig. 1)
- Remove lower valve gasket (Fig. 2)
- Dismount inlet and outlet valve (Fig. 3). Observe that the upper valve gasket is also pulled out. (It can still stick inside the cylinder head)
- Check valve head if defective (check centre pin)
- Mount valve gasket on inlet and outlet valve.
CAUTION: Ensure correct mounting position of the upper valve gasket (Fig. 4).
- Insert new inlet and outlet valve into valve head.
CAUTION: Observe correct position between valve centre hole and valve head centre pin.
- Place bottom valve gasket
- Place valve head with the new inlet and outlet valve. Tighten valve head screws crosswise (tightening torque 30 Nm).

Replacement inlet and outlet valves 3rd stage complete.



Fig. 1 - Loosen valve head screws



Fig. 2 - Remove lower valve gasket

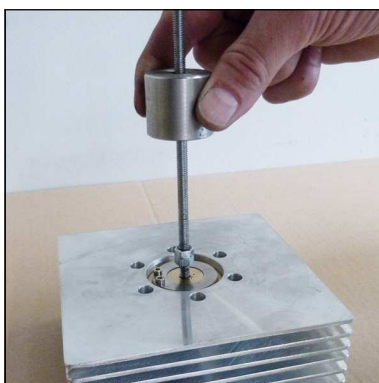

Fig. 3 - Remove inlet and outlet valve



Fig. 4 - Ensure correct mounting position of the upper valve gasket

A

MAINTENANCE AND SERVICE

Replace piston rings and needle bearings of the 2nd and 3rd stage

Replace piston rings and needle bearings of 2nd and 3rd stage as follows:

- Remove in- & outlet pipework
- Remove valve head bolts
- Remove valve head
- Remove lower valve gasket (see "replace in- / outlet valves 2nd & 3rd stage")
- Check condition of valve head
- Remove flange nuts of compression cylinder
- Take off compression cylinder and o-ring
- Turn crankshaft until piston is on TDC position
- Remove piston rings
- Fit piston rings in accordance to drawing "piston 2nd / 3rd stage" and lubricate by using compressor oil.
- *Remove cylinder flange bolts (only necessary small end bearing needs to be replaced)*
- *Take-off guide cylinder*
- *Remove O-ring*
- *Clean sealing surfaces*
- *Remove circlips and piston pin, take-off piston*
- *Remove small end bearing by using L&W special tool (Part number: 006663 / 005456)*
- *Fit new small end bearing by using special tool , lubricate bearing*
- *Lubricate piston pin bore*
- *Fit piston to conrod, secure piston pin by circlips*
- *Lubricate and fit O-ring to guide cylinder*
- *Refit guide cylinder*
- *Tighten flange bolts crosswise*
- Lubricate and fit O-ring to compression cylinder
- Lubricate piston skirt
- Compress piston rings by using L&W special tool and pipe wrench. Refit compression cylinder



Fig. 1 - take off compression cylinder



Fig. 2 - Piston 3rd Stage

Change piston rings and needle bearings of the 2nd and 3rd stage - continue

A

- Fit washers and nuts, tighten crosswise

See "In- / outlet valves 2nd and 3rd stage" for further instructions

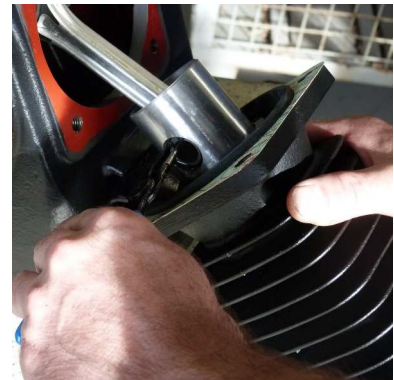

Fig. 1 - fit circlip

L&W special tool

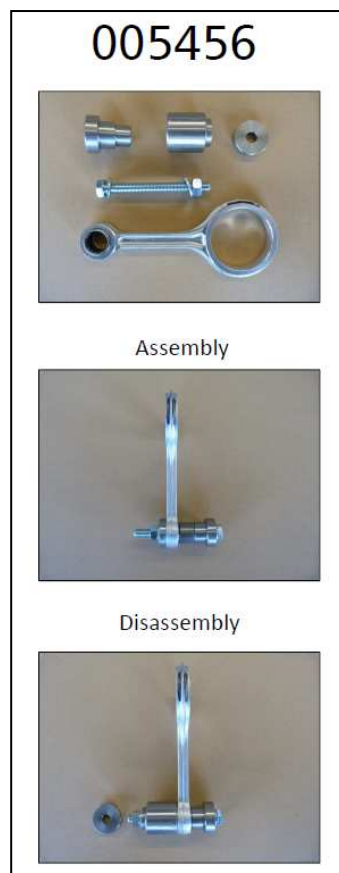

Fig. 2 - L&W special tool for 3rd stage 005456

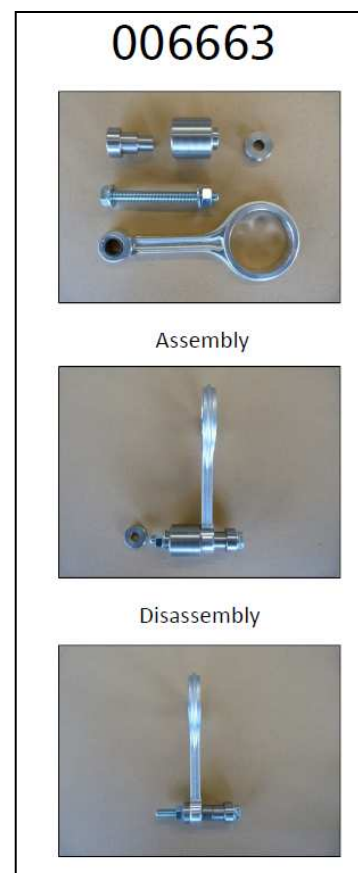

Fig. 3 - L&W special tool for 2nd stage 006663

MAINTENANCE AND SERVICE

Safety valves

Every pressure stage is equipped with a separate over pressure safety valve. Safety Valves avoid a non permissible high pressure at the specific pressure stages and limit maximum operation pressure of the compressor.

Safety valves are adjusted to:

- 1st Stage: 8 bar
- 2nd Stage: 50 bar
- 3rd Stage: max. final pressure

The adjusted blow-off pressure [bar] of the safety valves is indicated on their housings.

All safety valves are factory sealed with special L&W safety seals to avoid manipulation of the limit value settings.

Safety valves with removed seals have to be immediately checked for the prescribed settings and replaced if necessary.

The safety valve of the final stage is furthermore equipped with a knurled screw to be activated once.

Turning the knurled screw clockwise could vent the valve completely and therefore the final filter housing.

During normal operation conditions, the knurled screw has to be turned anti-clockwise up to the upper stop. An integrated circlip avoids complete unscrewing.

If a safety valve blows off, it indicates problems with either inlet or outlet valve of the following stage.



Note

Replace defective safety valves immediately!

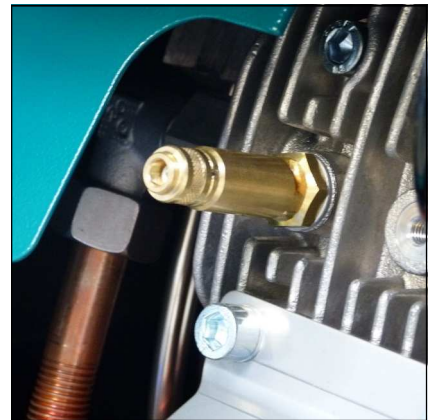

Safety valve 1st stage



Safety valve 2nd stage



Safety valve 3rd stage

A

Pressure maintaining / non return valve



Note

If the adjusted opening pressure of the pressure maintaining valve is higher than the final pressure of the compressor, the final pressure safety valve blows off before pressure maintaining valve opens (final pressure = 0 bar). When valve settings are not clear (e.g. after disassembly / repair), start the adjustment with a low basic setting (turn adjusting screw approx. 3 times in).

A pressure maintaining / non return valve is installed after the filter housing. It maintains a pressure of at least 150 bar inside the filter housing - this optimises filter efficiency.

Pressure maintaining valve

The pressure maintaining valve drains a large part of the water content of the compressed air mechanically by ensuring the minimum outlet pressure. This guarantees optimal drying and purification of the breathing air.

After starting the compressor, the pressure inside the final filter housing constantly increases. The pressure maintaining valve prevents the compressed air from blowing off (final pressure gauge = 0 bar).

When the adjusted opening pressure is reached (150 and 180 bar), the purified compressed air flows via pressure maintaining and non return valve to the filling valve.

The value of the opening pressure of the pressure maintaining valve can be read at the final pressure gauge. When opening pressure is reached, the pressure gauge value increases within a few seconds.



Pressure maintaining/non-return valve

MAINTENANCE AND SERVICE

Safety valve test



Note

Do not fill any tank during test phase!

Safety valve test as follows:

- Disconnect compressor from the electrical power supply and protect against unexpected restart.
- Remove the cover of the switch box.
- Switch on the "Test Safety Valve" switch (pressure switch will be deactivated!).
- Mount the cover of the switch box.
- Connect the compressor to the electrical power supply.
- Close filling valves.
- Start the compressor.
- Watch the final pressure gauge. The safety valve should open when reaching working pressure of the compressor. If not, switch off the unit and take out of service until the safety valve has been replaced.
- Switch off the compressor (compressor vented).
- Disconnect the compressor from the electrical power supply and protect against unexpected restart.
- Remove the cover of the switch box.
- Switch off the "Test Safety Valve" switch (pressure switch will be activated!).
- Mount the cover of the switch box.
- Connect the compressor to the electrical power supply.

The safety valve test is now completed.

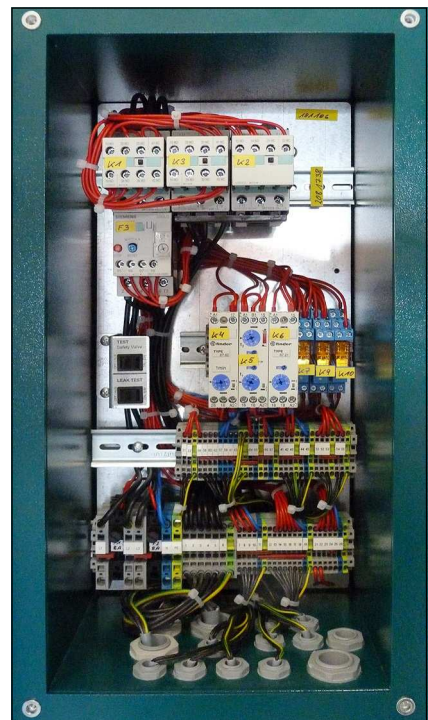

Switch box

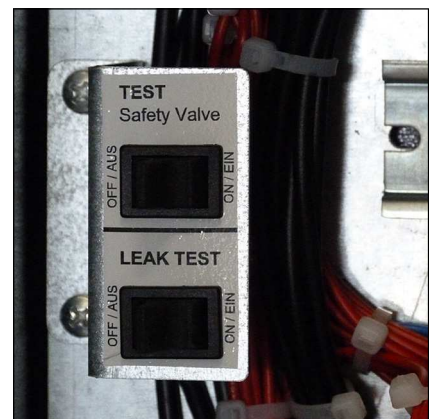

Safety valve test switch (up)

MAINTENANCE AND SERVICE

Leak test



Note

Do not fill any tank during test phase!

Leak test as follows:

- Disconnect the compressor from the electrical power supply and protect against unexpected restart.
- Remove the cover of the switch box.
- Switch on the leak test switch (solenoid valves will be deactivated!).
- Mount the cover of the switch box.
- Connect the compressor to the electrical power supply.
- Close filling valves.
- Start the compressor.
- Switch off the compressor at a pressure of approx. 150 bar.
- Verify the compressor for release noises. (A slight hiss of the air inlet filter nozzle can be ignored). If release noises occur, localise blow off position(s).
- Switch off the compressor.
- Disconnect the compressor from the electrical power supply and protect against unexpected restart.
- Remove the cover of the switch box.
- Switch off the leak test switch (solenoids will be activated!).
- Mount the cover of the switch box.
- Connect the compressor to the electrical power supply (compressor vented).

The leak test is now completed.

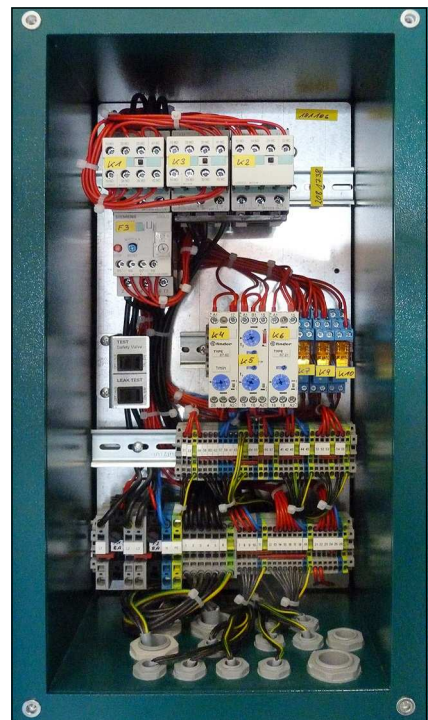

Switch box

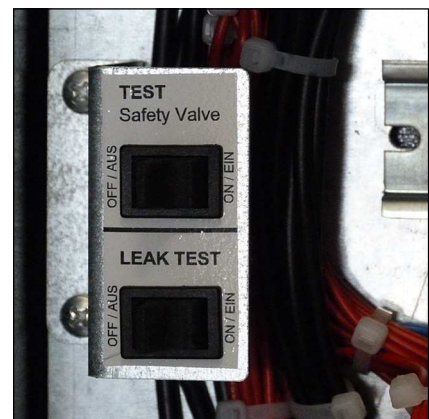

Leak test switch (lower)

MAINTENANCE AND SERVICE

Test of pressure equipment

According to the Pressure Equipment Directive (PED 97/23/EC) and TÜV Darmstadt (German supervising authorities). State: 10th of December, 2005

Subject: pressure equipment with a product permissible operating pressure [bar] x content volume [litres] from 200 up to 1000.

Example: Filter housing 1.7 l

Maximum operating pressure: 350 bar

Content volume: 1.7 litres

$350 \text{ bar} \times 1.7 \text{ litres} = 595$

595 is smaller than 1000 -> result: Test is applicable!!

Example: Filter housing 2.3 l

Maximum operating pressure: 350 bar

Content volume: 2.3 litres

$350 \text{ bar} \times 2.3 \text{ litres} = 805$

805 is smaller than 1000 -> result: Test is applicable!!

Pressure equipment from 200 up to 1000 have to be tested as follows:

1. Examination after 5 years by a qualified person or authorized organisations.

Visual inspection, inside and outside.

2. Examination after 10 years by a qualified person or authorized organisations.

Visual inspection, inside and outside.

In addition, a water pressure test is carried out at 1.5 times of the permissible vessel operating pressure.



A

MAINTENANCE RECORDS



MAINTENANCE RECORDS

Introduction form for the Operator

A

| No. | Surname, Name | Date | Place | Signature | Instructor |
|-----|---------------|------|-------|-----------|------------|
| | | | | | |
| | | | | | |
| | | | | | |
| | | | | | |
| | | | | | |
| | | | | | |
| | | | | | |
| | | | | | |
| | | | | | |
| | | | | | |
| | | | | | |
| | | | | | |
| | | | | | |
| | | | | | |
| | | | | | |
| | | | | | |
| | | | | | |
| | | | | | |
| | | | | | |
| | | | | | |
| | | | | | |

By adding themselves to this list, the person that signs it confirms having been given a yearly introduction/instruction about the function and operation of the compressor unit. Furthermore, they have be informed about the relevant safety rules and regulations (TRG, DGRL, BetrSichV, GSG, GSGV).

STORAGE

Conservation / storage of the compressor

If the compressor is not to be used for an extended period of time, we recommend the following conservation work to be carried out before the storage:

- Run the compressor at 200 bar for approx. ten minutes
- Drain warm oil and replace by new oil.
- Open filling valves and run the compressor for a few minutes.
- Stop the compressor and open the drain valves.
- Close filling valves.
- Open the final filter housing and lubricate the O-Ring with a food grade grease or silicone grease.
- Store the compressor in a cool dry place free from dust and contamination. A cover is recommended as long as condensation can be avoided.

De-conservation, commissioning

After the compressor has been stored, the following steps are to be taken:

- Replace the final purification filter.
- Check oil level, replace oil if necessary. Fuel Driven Units only: Fill up fuel tank to top level to avoid corrosion.
- Inspect the condition of the v-belts, replace if necessary
- Inspect the filling hoses visually for signs of deterioration, replace as necessary.
- Fix filling valves by e.g. cable strips to avoid whipping around wildly. Open filling valves.
- Open the filling valves and run the compressor for approx 10 minutes with the filling valves open.
- Close the filing valves and allow the compressor to build up to working pressure.
- Check the correct safety valve setting and/or pressure switch setting (option).
- Check all connections and pipe work for leaks, retighten if necessary.

Once the above steps are completed to satisfaction, the unit is ready to use.

STORAGE

Transportation instructions

- Parts which need to be dismantled for transport purposes must be carefully replaced and secured before taking into operation.
- The transport may only be carried out by trained personnel.
- For transportation, only use lifting devices and equipment with sufficient lifting power.
- Do not stand or work under suspended loads.
- Also separate from minor relocation machinery / system of any external energy supply. Before recommissioning, reconnect the machine to the mains according to regulations.
- When recommissioning, proceed according to the operating instructions..

Disposal

The product must be disposed in accordance with national waste disposal regulations and by an appropriate waste disposal company.

Electric and electronic components

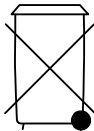

EU-wide regulations for the disposal of electric and electronic appliances which have been defined in the EU Directive 2002/96/EC and in national laws are effective from August 2005 and apply to this device.

Common household appliances can be disposed by using special collecting and recycling facilities. However, as this device has not been registered for household usage, it must not be disposed of through these means.

The device can be returned to L&W. Please do not hesitate to contact us if you have any further questions on this issue.

Operating Instructions

ECC - Electronic compressor control





TABLE OF CONTENTS

General Information

| | |
|--------------------------------------|---|
| General Information | 3 |
| Description of Warning Symbols | 3 |

Description

| | |
|--------------------------------|---|
| Specifications / Options | 4 |
| Switchboard | 5 |

Operation and Function

| | |
|--|----|
| Main Menu | 6 |
| Selection Menu (M100) | 7 |
| Display Menu (M200) | 8 |
| Inter-Stage Pressure Display..... | 8 |
| Display II (M270) | 9 |
| Settings Menu (M300)..... | 10 |
| Set Stop Pressure - automatic mode (M320)..... | 11 |
| Set Restart Pressure - automatic mode (M330)..... | 11 |
| Set Stop Pressure - semi-automatic mode (M340) | 11 |
| Test Menu (M400) | 12 |
| Test Solenoids (M420) | 12 |
| Test safety valve (M430) | 13 |
| Test stop without venting (M440) | 13 |
| Statistics Menu (M500)..... | 14 |
| Maintenance Menu (M600) | 15 |
| Confirm Maintenance (M680)..... | 16 |
| Operation Mode (M700)..... | 17 |
| Language Menu (M750) | 17 |
| Adjusting Display Backlight..... | 18 |
| Software Update | 18 |
| Spare part lists..... | 19 |
| Manufacturer in terms of 97/23/EC..... | 20 |

B



GENERAL INFORMATION

General Information

We strongly recommend reading this manual thoroughly prior to operation and follow all the safety precautions precisely. Damage resulting from any deviation from these instructions is excluded from warranty and liability for this product. Carry out other commissioning steps only if you have fully understood the following contents.

Before commissioning and using the unit, carry out all the essential preliminary work and measures concerning legal regulations and safety. These are described on the following pages of this operation manual.

B

Description of marks and warning signs

The following warning signs are used in this document to identify the corresponding warning notes which require particular attention by the user. The warning signs are defined as follows:



Caution

Indicates an imminently hazardous situation which, if not avoided, could result in serious injury, physical injury or death.



Warning

Indicates a potentially hazardous situation which, if not avoided, could result in physical injury or damage to the product or environment.



Note

Indicates additional information on how to use the unit.



DESCRIPTION

Specifications and Options

All L&W compressors can be optionally equipped with the all-electrical computer supported control system "ECC". It is easy to operate and allows multiple and individual settings.

Specifications

- LCD-Display with key pad
- Automatic & semi-automatic operation mode
- Automatic dump system
- Integrated counter for operation hours
- Integrated counter for load cycles
- Maintenance intervals automatically displayed
- Required service part numbers automatically displayed
- Fully adjustable pressure ranges for start and stop
- Warning messages ("Housing Open" / "Emergency Switch")
- Check of end-pressure safety valve possible
- Auto switch-off when system is not running
- Extendable by additional modules (e.g. external filling panel)
- Easy to operate menu
- Door position switch (housing open message)
- Load-free or depressurised start cycles

Options

- Oil pressure control
- Oil temperature control
- Cylinder head temperature control
- Inter stage pressure monitoring
- PIN controlled access
- Master / slave option (if more than one ECC equipped compressors are combined)

DESCRIPTION

Switchboard



| No. | Description |
|-----|------------------------------|
| 1 | LCD Display |
| 2 | Key Pad |
| 3 | LED Display (Compressor OFF) |
| 4 | LED Display (Power) |
| 5 | LED Display (Compressor ON) |



OPERATION AND FUNCTION

Main Menu

Immediately after the compressor has been connected to power, the ECC-display shows the following Main Menu::

| | |
|-------------|--------------|
| Charging | 0 min |
| Total | 0,0 h |
| Start : 1 | Stop : 0 |
| Help: * | OFF |
| Final Press | 0 bar |

Present filling time in minutes

Total operation hours

Key 1 to start compressor / Key 0 to stop compressor

* Key leads to submenus Current operation state = Off

Present filling pressure

B

The following keys can now be used:

| Key | Function / Description |
|-----|-------------------------------|
| 1 | Start - Starts the compressor |
| 0 | Stop - Stops the compressor |
| * | Leads to the submenus |

After typing the * key the following Selection Menu appears.



OPERATION AND FUNCTION

Selection Menu (M100)

After typing the * key in the Main Menu the following Selection Menu appears.

| Selection: | | |
|------------|----------------|---|
| 2 | Display | Key 2 leads to submenu "Display" |
| 3 | Settings | Key 3 leads to submenu "Settings" |
| 4 | Test | Key 4 leads to submenu "Test" |
| 5 | Statistics | Key 5 leads to submenu "Statistics" |
| 6 | Maintenance | Key 6 leads to submenu "Maintenance" |
| 7 | Operation Mode | Key 7 leads to submenu "Operation mode" |
| (M100) | Return : # | Key # leads back to "Main Menu" |

(M100) tells that you are currently on menu page 100.



Note

At any time, the unit can be started with key 1 or shut down with key 0.
Caution: Risk of accident during maintenance work!

B

OPERATION AND FUNCTION

Display Menu (M200)

Pushing key 2 in the Selection Menu leads to Submenu "Display".

| Display I: | |
|------------|-----------------|
| 2 | Press. Stage 1 |
| 3 | Press. Stage 2 |
| 4 | Press. Stage 3 |
| 5 | Cyl. Head Temp. |
| 6 | Oil Temp. |
| 7 | Display II |
| (M200) | Return : # |

Key 2 shows current pressure of the 1st stage*

Key 3 shows current pressure of the 2nd stage

Key 4 shows current pressure of the 3rd stage

Key 5 shows temperature of the final stage cylinder head

Key 6 shows the oil temperature

Key 7 shows Display II

Key # leads back to "Main Menu"

(M200) tells that you are currently on menu page 200.

By pushing key 2 (inter-stage pressure 1) the following Display appears.

Inter-Stage Pressure Display

Pushing key 2 in the Display Menu leads to the Inter-Stage Pressure 1 Display Menu.

| | |
|-----------------------|---------|
| Charging | 0 min |
| Total | 0,0 h |
| Start: 1 | Stop: 0 |
| Help:* | OFF |
| Press. | 0 bar |
| 1 st Stage | 0,0 bar |

Use keys 3 to 6 in the Menu "Display I" to change between the displayed values.



Note

Pushing key 8 in the display menu "Display II" leads to the option "Pressure200/300" for compressors with 2 filling pressures. Displayed in field 3 of the display menu "Display I".



OPERATION AND FUNCTION

Display II (M270)

Pushing key 7 in the Selection Menu leads to Menu "Display II".

Display II:

| Press. | Temp. |
|--------|------------|
| 4: 0 | C: 0 |
| 5: 0 | D: 0 |
| 6: 0 | E: 0 |
| 7: 0 | F: 0 |
| bar | °C |
| (M270) | Return : # |

This display shows further customer specific pressure and temperature values.

Key # leads back to "Main Menu"

B

OPERATION AND FUNCTION

Settings Menu (M300)

Pushing key 3 in the Selection Menu leads to the Settings Menu.

| | |
|-----------------------|----------------|
| Settings: | |
| Automatic | |
| 2 | Stop pressure |
| 3 | Restart Press. |
| Semi-Automatic | |
| 4 | Stop Pressure |
| 9 | Close |
| (M300) | Return : # |

Key 2 leads to submenu „Set Stop Pressure“

Key 3 leads to submenu „Set Restart Pressure“

Key 4 leads to submenu „Set Stop Pressure“

Key 9 leads back to submenu "Selection"

Key # leads back to "Main Menu"

B

Use menu M700 to change between "Automatic" and "Semi-Automatic" mode.

Restart pressure can only be set in "Automatic Mode".

Prior to setting the pressure, start the safety valve test.



Attention during maintenance

During automatic mode, the compressor can automatically start by itself at any time, depending on the selected restart pressure (see "Set Restart Pressure" M330).



OPERATION AND FUNCTION

Set Stop Pressure - automatic mode (M320)

Only valid in automatic mode, see menu M700.

Set
Stop Pressure:
Actual: 330 bar
7 New Value:
>> XXX bar
4 (050,, 333)
8 Confirm
(M320) Return : #

Current restart pressure
Key 7 if restart pressure should be changed
XXX indicates modified stop pressure
Chooseable pressure range for restart pressure
Key 8 confirms new restart pressure
Key # leads back to "Main Menu"

B

Set Restart Pressure - automatic mode (M330)

Only valid in automatic mode, see menu M700.

Set
Restart Pressure:
Actual: 180 bar
7 New Value:
>> XXX bar
4 (030,, 310)
8 Confirm
(M330) Return : #

Current restart pressure
Key 7 if restart pressure should be changed
XXX indicates modified restart pressure
Chooseable pressure range for restart pressure
Key 8 confirms new restart pressure
Key # leads back to "Main Menu"

Set Stop Pressure - semi-automatic mode (M340)

Only valid in semi-automatic mode, see menu M700.

Set
Stop Pressure:
Actual: 180 bar
7 New Value:
>> XXX bar
4 (030,, 310)
8 Confirm
(M340) Return : #

Current stop pressure
Key 7 if stop pressure should be changed
XXX indicates modified stop pressure
Chooseable pressure range for stop pressure
Key 8 confirms new restart pressure
Key # leads back to "Main Menu"

OPERATION AND FUNCTION

Test Menu (M400)

Pushing key 4 in the Selection Menu leads to the Test Menu.

| Test: | |
|--------|--------------|
| 2 | Solenoids |
| 3 | Safety Valve |
| 4 | Test-Stop |
| 9 | Close |
| (M400) | Return : # |

Key 2 leads to submenu "Test Solenoids"

Key 3 leads to submenu "Test Safety Valve"

Key 4 leads to submenu "Test Stop without Venting"

Key 9 leads back to submenu "Selection"

Key # leads back to "Main Menu"

B

Test Solenoids (M420)

Pushing key 2 in the Selection Menu leads to Submenu "Test Solenoids".

| Test Solenoids | |
|----------------|------------|
| 3 | open |
| 7 | close |
| 9 | Close |
| (M420) | Return : # |

Key 3 opens solenoids

Key 7 closes solenoids

Key 9 leads back to submenu „Test“

Key # leads back to "Main Menu"



Note

This menu can not be left unless solenoids have been closed by key 7.

OPERATION AND FUNCTION

Test safety valve (M430)

Pushing key 3 in the Test Menu leads to Submenu "Test Safety Valve".



Note

Prior to starting the Test, close all filling connections (also connected filling panels if necessary). During this test, the compressor passes the selected stop pressure (see Menu M320) to test the correct function of the final pressure safety valve. This would limit the maximum operating over pressure of the unit in case of malfunction.

B

Test

Safety Valve

Close Filling Valves!

| | |
|-------------------|--------|
| 5 Start | 0 Stop |
| 9 Close | |
| (M430) Return : # | |

Key 5 to start test Key 0 to stop test

Key 9 leads back to submenu „Test“

Key # leads back to "Main Menu"

Test stop without venting (M440)

Pushing key 4 in the Test Menu leads to Menu "Test Stop without Venting".



Note

This test is only operable when the compressor has been started with key 1. This test mainly checks the leak tightness of pressure vessels, pressurised pipes, safety valves and the compressor block.

Test

stop without venting:

| | |
|-------------------|-----|
| 5 Stop | |
| 6 Vent | |
| Pressure | 0 |
| | bar |
| 9 Close | |
| (M440) Return : # | |

Key 5 stops compressor during test run

Key 6 vents compressor after leak search has been finished

Shows current filling pressure

Key 9 leads back to submenu „Test“

Key # leads back to "Main Menu"



OPERATION AND FUNCTION

Statistics Menu (M500)

Pushing key 5 in the Selection Menu leads to Submenu "Statistics".

| Statistics | |
|-------------------|---------|
| Operation Hours: | 0,0 h |
| Start cycles: | 00 |
| Max Press | 000 bar |
| 9 Close | |
| (M500) Return : # | |

Total operation hours of compressor unit

Total number of compressor starts

Maximum working pressure of unit (set by safety valve test)

Key 9 leads back to submenu „Selection“

Key # leads back to "Main Menu"

Push key 5 to get information on which ECC software version is currently installed on your system (M505), i.e.: By pushing key 2, the total load cycles of the filter housing are being indicated.

B

OPERATION AND FUNCTION

Maintenance Menu (M600)

Pushing key 6 in the Selection Menu leads to the "Maintenance Menu".

| Hours remaining | | |
|-------------------|--------|--|
| Oil change | 14 h | Shows remaining hours of listed components (i.e. next oil change in 14 hours,...) |
| Sinter filt | 989 h | |
| Silencer | 4989 h | |
| Valves | 5989 h | |
| Oil filter | 1000 h | |
| 8 Change done | | Key 8 leads to submenu "Receipt Maintenance" |
| 9 Close | | Key 9 leads back to submenu „Selection“ |
| (M600) Return : # | | Key # leads back to "Main Menu" |

Remaining hours depend on the type. At the end of any remaining hours, the display indicates a warning message. Furthermore, the display informs about any possibly necessary spare parts with the corresponding L&W service part number.



Attention during maintenance

During automatic mode, the compressor can automatically start by itself at any time, depending on the selected restart pressure (see "Set Restart Pressure" M330).



OPERATION AND FUNCTION

Confirm Maintenance (M680)

| Confirm Maintenance | |
|---------------------|----------------|
| 2 | Oil change |
| 3 | Sinter filters |
| 4 | Silencer |
| 5 | Valves |
| 6 | Oil filter |
| (M680) | Return : # |

Key 2 receipts oil change
Key 3 receipts change of sinter filters
Key 4 receipts change of silencer
Key 5 receipts change of valves
Key 6 receipts oil filter
Key # leads back to "Main Menu"

B

Display confirms any reset of "Hours remaining" with the following message:

| Confirm Maintenance | |
|---------------------------|------------|
| Operation Hours Meter Set | |
| 9 | Close |
| (M680) | Return : # |

Key 9 leads back to submenu "Hours remaining"
Key # leads back to "Main Menu"

OPERATION AND FUNCTION

Operation Mode (M700)

Pushing key 7 in the Selection Menu leads to the menu "Operation Mode".

Activated modes are always displayed in bolt letters (above example: **Semi-Automatic**).

Further settings can be made in the Settings Menu (M300).

B

| Betriebsart: | |
|--------------|-----------------------|
| 2 | Automatic |
| 3 | Semi-Automatic |
| 4 | bar /mpa |
| 5 | Sprache |
| 9 | Close |
| (M700) | Return : # |

Key 2 activates automatic mode

Key 3 activates semi-automatic mode

Key 4 selects between bar and MPa (optional)

Key 5 leads to the "Language Menu"

Key 9 leads back to submenu „Selection“

Key # leads back to "Main Menu"

Language Menu (M750)

| Language Menu | |
|---------------|-------------|
| 2 | German |
| 3 | English |
| 4 | French |
| 5 | Spanish |
| 6 | Dutch |
| 7 | Language II |
| (M750) | Return : # |

Key 7 optional language (e.g. Chinese)

Key # leads back to "Main Menu"

OPERATION AND FUNCTION

Adjusting Display Backlight

The brightness of the display can be adjusted with an adjusting screw on the back of the control.

Software Update

Software updates can only be carried out by L&W. To carry out an update, the device has to be send to the L&W service.

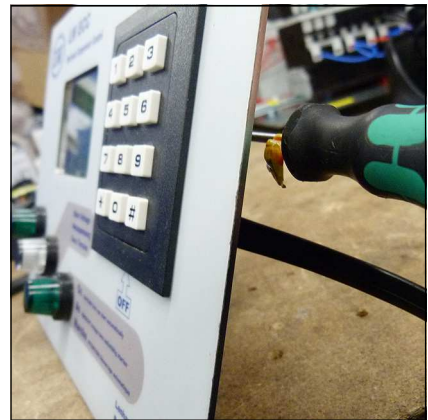

Adjust brightness

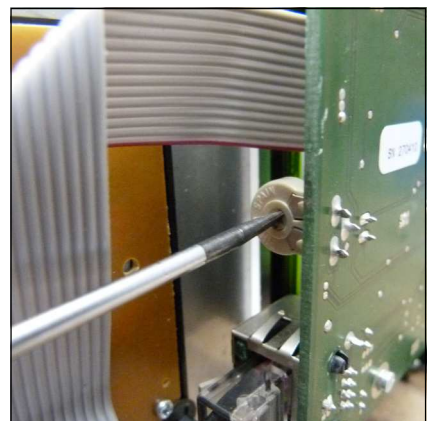

Adjust brightness

SPARE PART LISTS

| Best.-Nr. / Order No. | Benennung | Description |
|-----------------------|--|---|
| 002141 | 1. Stufe Druckaufnehmer 0-10 bar | 1st stage pressure sensor 0-10 bar |
| 002142 | 2. Stufe Druckaufnehmer 0-60 bar | 2nd stage pressure sensor 0-60 bar |
| 002143 | Endstufe Druckaufnehmer 0-400 bar | Final stage pressure sensor 0-400 bar |
| 006890 | Druckaufnehmer 420 bar Version 0-600 bar | Pressure sensor 420 bar version 0-600 bar |
| 004840 | Öldruckaufnehmer 0-6 bar | Oil pressure sensor 0-6 bar |
| 006912 | Öltemperatursensor | Oil temperature sensor |
| 003501 | Zylinderkopf - Temperatursensor | Cylinderhead temperature sensor |

B



002141 / 002142 / 002143 / 004840
Druckaufnehmer / Pressure sensor



006890 - Druckaufnehmer 420 bar /
Pressure sensor 420 bar



006912 - Öltemperatursensor
Oil temperature sensor



003501 - Zylinderkopf - Temperatursensor
Cylinderhead temperature sensor



LENHARDT & WAGNER GMBH

B

Manufacturer in terms of 97/23/EC

The full name and address of the manufacturer is:

Lenhardt & Wagner GmbH

An der Tuchbleiche 39
68623 Hüttenfeld / Germany

Phone: +49 (0) 62 56 - 85 88 0 - 0

Fax: +49 (0) 62 56 - 85 88 0 - 14

E-Mail: service@lw-compressors.com

Internet: www.lw-compressors.com





**ERSATZTEILLISTEN / SPARE PARTS LISTS
DETAILANSICHTEN / DETAILED VIEWS**

C



Inhaltsverzeichnis - Table of Contents

| | |
|--|----|
| Gehäuse - Housing | 1 |
| Schalttafel - Control Board..... | 3 |
| Kompressorblock - Compressor Block | 5 |
| Kurbelwelle - Crankshaft | 9 |
| Kolben 1. Stufe - Piston 1st Stage | 11 |
| Kolben 2. Stufe - Piston 2nd Stage..... | 13 |
| Kolben 3. Stufe - Piston 3rd Stage | 15 |
| Saug+Druckventil 1. Stufe - In+Outlet Valve 1st Stage..... | 17 |
| Saug+Druckventil 2. Stufe - In+Outlet Valve 2nd Stage | 18 |
| Saug+Druckventil 3. Stufe - In+Outlet Valve 3rd Stage | 19 |
| Öl+Wasserabscheider 1. Stufe - Oil+Water Separator 1st Stage..... | 21 |
| Öl+Wasserabscheider 2. Stufe - Oil+Water Separator 2nd Stage | 23 |
| Filtergehäuse 1,7 l - Filter Housing 1.7 ltr | 25 |
| Kühler 1. Stufe - Cooler 1st Stage | 27 |
| Kühler 2. Stufe - Cooler 2nd Stage | 29 |
| Kühler 3. Stufe - Cooler 3rd Stage..... | 31 |
| Druckhalteventil - Pressure Maintaining Valve..... | 33 |
| Druckschalter - Pressure Switch | 35 |
| Sicherheitsventil - Safety Valve | 37 |
| Motor | 39 |
| Ansaugfilter - Air Intake Filter | 41 |
| Ölpumpe - Oil Pump | 43 |
| Ölablassschlauch - Oil Drainage Tube | 45 |



ERSATZTEILLISTE / SPARE PART LIST

Gehäuse / Housing

| Best.-Nr. / Order No. | Benennung | Description |
|-----------------------|--|------------------------------------|
| 001030 | Zylinderschraube M6x16mm DIN912 8.8 ZN | Allen Screw M6x16mm DIN912 8.8 ZN |
| 001041 | Zylinderschraube M8x25mm DIN912 8.8 ZN | Allen bolt M8x25mm DIN912 8.8 ZN |
| 001178 | U-Scheibe A6 DIN9021 ZN | Washer A6 DIN9021 ZN |
| 001182 | U-Scheibe A8 DIN9021 ZN | Washer A8 DIN9021 ZN |
| 002720 | Kompressorfuß mit Gummieinlage | Rubber Foot |
| 009907 | Grundkonsole LW 450 EC III | Frame LW 450 EC III |
| 009908 | Ventilatorschutz LW 450 EC III | Protective cover fan LW 450 EC III |
| 010085 | Eingriffschutz Block LW 450 EC III | Safety Guard Block LW 450 EC III |
| 010086 | Eingriffschutz Motor LW 450 EC III | Safety Guard Motor LW 450 EC III |

C

DETAILANSICHT / DETAILED VIEW

Gehäuse / Housing

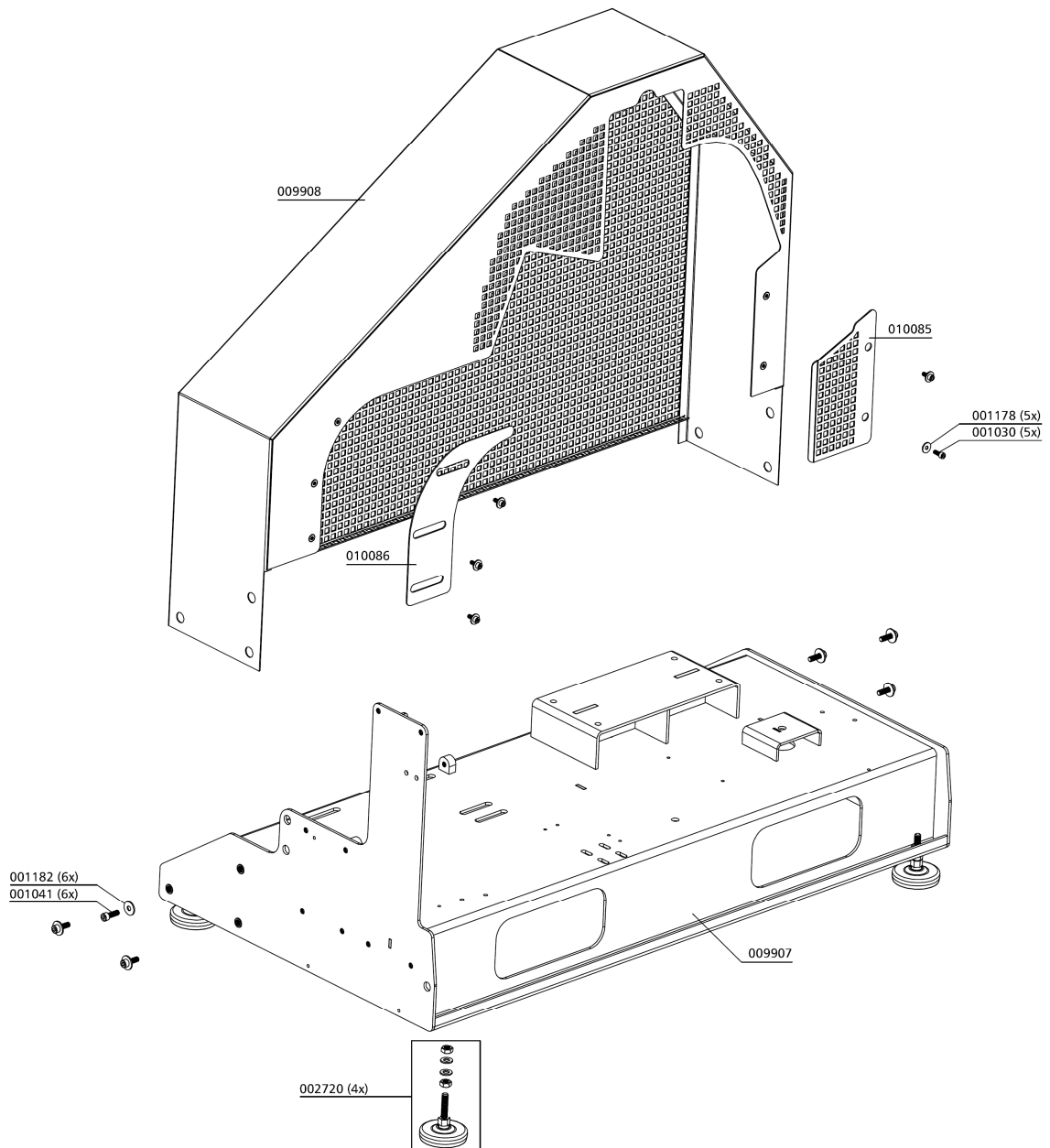

C



ERSATZTEILLISTE / SPARE PART LIST

Baugruppe: Schalttafel / Control Board

| Best.-Nr. / Order No. | Benennung | Description |
|-----------------------|--|--|
| 002089 | Betriebsstunderzähler 230V | Hour Counter 230V |
| 002502 | Taster blau (komplett inkl. Halterung und Schließer) | Blue button (complete with braket and closing contact) |
| 002504 | Taster grün (komplett inkl. Halterung und Schließer) | Green button (complete with braket and closing contact) |
| 003121 | Not-Halt Schalter | Emergency switch |
| 008153 | Taster rot (komplett inkl. Halterung, Schließer und LED) | Red button (complete with braket, closing contact and LED) |

C

DETAILANSICHT / DETAILED VIEW

Baugruppe: Schalttafel / Control Board

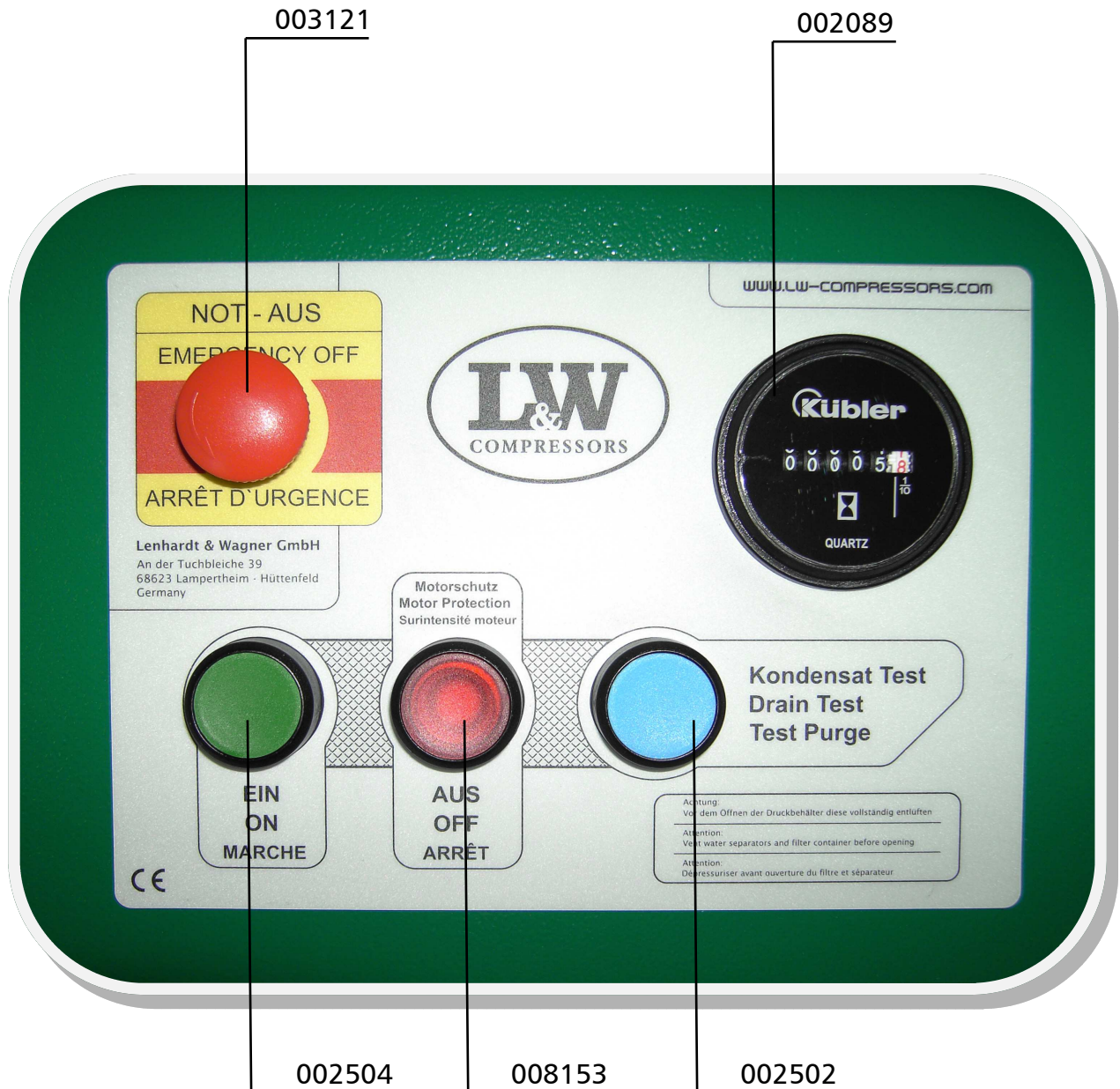

C



ERSATZTEILLISTE / SPARE PART LIST

Baugruppe: Kompressorblock / Assembly: Compressor Block

| Best.-Nr. / Order No. | Benennung | Description |
|-----------------------|--|--|
| 000180 | Ölschlauchstutzen | Oil hose clip |
| 000209 | Öleinfüllstopfen | Oil Filler Plug |
| 000220 | Sicherheitsventil G3/8", 8bar | Safety valve G3/8", 8bar |
| 000225 | Sicherheitsventil G3/8", 50bar | Safety valve G3/8", 50bar |
| 000253 | Untere Ventildichtung 2.Stufe | Lower valve gasket 2nd stage |
| 000254 | Obere Ventildichtung 2.Stufe | Upper valve gasket 2nd stage |
| 000257 | Obere Ventildichtung 1.Stufe | Upper valve gasket 1 st stage |
| 000258 | Untere Ventildichtung 1.Stufe, Kupfer | Lower valve gasket 1 st stage, copper |
| 000270 | Ventilkopf 2.Stufe | Valve head 2nd stage |
| 000274 | Zylinder Ø42mm | Cylinder Ø42mm |
| 000344 | Führungszylinder | Guide Cylinder |
| 000498 | U-Scheibe DIN 125 A6 | Washer DIN 125 A6 |
| 000710 | Verschraubung GE06LRFCX | Connection GE06LRFCX |
| 000738 | Verschraubung GE 08 PLR 1/4" | Connection GE 08 PLR 1/4" |
| 000761 | Verschraubung WE 08 PLR CFX 1/4" | Elbow Connection WE 08 PLR CFX 1/4" |
| 000817 | Verschraubung GE15LR3/8CFX | Connection GE15LR3/8CFX |
| 000818 | Verschraubung GE15LRFCX | Connection GE15LRFCX |
| 000837 | Verschlussstopfen VSTI R1/8" ED | Plug VSTI R1/8" ED |
| 000838 | Verschlussstopfen VSTI R1/4" ED | Plug VSTI R1/4" ED |
| 000839 | Verschlussstopfen VSTI R3/8" ED | Plug VSTI R3/8" ED |
| 000863 | Verschraubung WE 18L R A3C | Elbow Connection WE 18L R A3C |
| 000919 | Reduzierung RI3/4X1/2CFX | Reducer RI3/4X1/2CFX |
| 000952 | Sechskantschraube M6x20mm, DIN933, 8.8 | Hexagon Bolt M6x20mm, DIN933, 8.8 |
| 000961 | Stiftschraube M8x25mm DIN939 | Threaded Stud M8x25mm DIN939 |
| 001056 | Zylinderschraube M8x60 DIN 912 8.8 ZN | Allen bolt M8x60 DIN 912 8.8 ZN |
| 001058 | Zylinderschraube M8x70 DIN 912 8.8 ZN | Allen bolt M8x70 DIN 912 8.8 ZN |
| 001060 | Zylinderschraube M8x80 DIN 912 8.8 ZN | Allen bolt M8x80 DIN 912 8.8 ZN |
| 001088 | Zylinderschraube M10x60 DIN 912 8.8 ZN | Allen bolt M10x60 DIN 912 8.8 ZN |
| 001096 | Zylinderschraube M10x120mm DIN912 8.8 ZN | Hexagon Bolt M10x120mm DIN912 8.8 ZN |
| 001100 | Sechskantschraube M10x25 DIN 933 8.8 ZN | Hexagon screw M10x25 DIN 933 8.8 ZN |



ERSATZTEILLISTE / SPARE PART LIST

Baugruppe: Kompressorblock / Assembly: Compressor Block

| Best.-Nr. / Order No. | Benennung | Description |
|-----------------------|---|--------------------------------------|
| 001104 | Sechskantschraube M10x50 DIN933 8.8 ZN | Hexagon screw M10x50 DIN933 8.8 ZN |
| 001158 | Mutter M8 DIN 934 ZN | Nut M8 DIN 934 ZN |
| 001163 | Mutter M10 DIN934 ZN | Nut M10 DIN934 ZN |
| 001181 | U-Scheibe A8 DIN 125 ZN | Washer A8 DIN 125 ZN |
| 001186 | U-Scheibe A10 | Washer A10 |
| 001188 | U-Scheibe A10 DIN 125 ZN | Washer A10 DIN 125 ZN |
| 001190 | Federring A10 DIN127 ZN | Spring Washer A10 DIN127 ZN |
| 001274 | O-Ring 50 x 2,5 NBR70, ab 05/2012 | O-Ring 50 x 2,5 NBR70, since 05/2012 |
| 001346 | Sicherungsring A40 DIN471 | Circlip A40 DIN471 |
| 001766 | O-Ring, Lagerdeckel 140 x 2 NBR70 | O-Ring Bearing Cover 140 x 2 NBR70 |
| 001828 | U-Scheibe A10,5 DIN6340 ZN | Washer A10,5 DIN6340 ZN |
| 002111 | Zylinder Æ95, 1.Stufe | Cylinder 1st stage |
| 002358 | Schnellkupplung gerade G1/8"- 6mm | Quick Release Coupling G1/8"- 6mm |
| 002367 | Ventilkopf 3.Stufe | Valve head 3rd stage |
| 002478 | Zylinder 3.Stufe, Æ18 | Cylinder 3rd stage |
| 002932 | Distanzbolzen M6 | Spacer M6 |
| 003189 | Schlauschelle | Hose Clip |
| 003190 | Entlüftungsschlauch | Ventilation Hose |
| 003191 | Öleinfüllstopfen | Oil filter plug |
| 003286 | Ölschauglas | Oil gauge glass |
| 003766 | Aludichtring für G3/8" | Alloy Seal Ring for G3/8" |
| 004749 | PG Schlauchdurchführung, PVC | PVC hose c/W connection |
| 006377 | Alu-Distanzblock Kompressorblock | Alloy Spacer Compressor Block |
| 006378 | Alu-Distanzblock Kompressorblock | Alloy Spacer Compressor Block |
| 008696 | Sechskantschraube M10x30 DIN933 8.8 ZN | Hexagon Screw M10x30 DIN933 8.8 ZN |
| 008849 | Ölrohr | Oil Pipe |
| 008850 | Wellendichtringdeckel | Shaft Seal Cover |
| 008873 | Wellendichtring NBR RX 40 x 62 x 10 RST | Shaft Seal NBR RX 40 x 62 x 10 RST |
| 008874 | O-Ring 108x2 NBR 70 | O-Ring 108x2 NBR 70 |
| 008877 | O-Ring 81 x 2 NBR 70 | O-Ring 81 x 2 NBR 70 |



ERSATZTEILLISTE / SPARE PART LIST

Baugruppe: Kompressorblock / Assembly: Compressor Block

| Best.-Nr. / Order No. | Benennung | Description |
|-----------------------|---|---|
| 009004 | Kurbelwellenlager (Schwungradseite) | Main Roller Bearing (Position: Flywheel Side) |
| 009005 | Kurbelwellenlager (Ölpumpenseite) | Main Roller Bearing (Position: Oil Pump Side) |
| 009053 | Lagerdeckel | Main Bearing Flange |
| 009132 | Stiftschraube DIN 939, 8.8, M10x30, ZN | Threaded Stud DIN 939, 8.8, M10x30, ZN |
| 009169 | Kurbelgehäuse | Crankcase |
| 009601 | U-Scheibe DIN 1441 ST ZN 8 | Washer DIN 1441 ST ZN 8 |
| 009649 | Ventilkopf 1.Stufe | Valve head, 1st stage |
| 009687 | Halteblech-Ölschlauch LW 450 E / 450 EC | Bracket Oil Hose LW 450 E / 450 EC |
| 009688 | Halteblech-Ölschlauch LW300-530 ES | Bracket Oil Hose LW300-530 ES |
| 009694 | Öleinfüllschlauch Ø18mm, l=390mm, LW 450 E / 450 EC | Oil filler hose Ø18mm, l=390mm, LW 450 E / 450 EC |
| 009695 | Öleinfüllschlauch Ø18mm, l=325mm, LW 450 ES | Oil filler hose Ø18mm, l=325mm, LW 450 ES |
| 009852 | Gewindestange, M6x211mm | Threaded bar, M6x211mm |
| | | |
| | BG Ansaugfilter | Ass: Intake Filter |
| | BG Kurbelwelle | Ass: Crankshaft |
| | BG: Ölablassschlauch | ASS: Oil Drainage Tube |
| | BG: Ölpumpe | ASS: Oil Pump |
| | BG: Kolben 1.Stufe | Ass: Piston 1 st stage |
| | BG: Kolben 2.Stufe | ASS: Piston 2nd stage |
| | BG: Kolben 3.Stufe | ASS: Piston 3rd stage |
| | BG: Ventil 1.Stufe | Ass: Valve 1 st stage |
| | BG: Ventil 2.Stufe | ASS: Valve 2nd stage |
| | BG: Ventil 3.Stufe | ASS: Valve 3rd stage |

Kurbelwelle / Crankshaft

| Best.-Nr. / Order No. | Benennung | Description |
|-----------------------|---|---|
| 000245 | Sicherungsring DIN 471 65 x 2,5 | Circlip DIN 471 65 x 2,5 |
| 000247 | Anlaufscheibe Kurbelwelle, mit Innenfase | Thrust Washer, chamfered version |
| 000267 | Pleuel LW 450 1.Stufe | Conrod 1 st Stage LW 450 |
| 000268 | Pleuel LW 450 2.&3.Stufe | Conrod c/w Needle Bearing |
| 001189 | Schnorrnscheibe S10 N0110 ZN | Clamp Washer S10 N0110 ZN |
| 001207 | Passfeder, A8x7x35mm DIN6885 | Woodruff Key |
| 003281 | Nadellager Pleuel Ø28xØ22x20mm | Needle bearing, con-rod Ø28xØ22x20 mm |
| 003836 | Nadellager Pleuel Ø22x Ø16x16mm | Needle Bearing, conrod Ø22xØ16x16mm |
| 004809 | Konischer Schraubenkopf M6x8mm | Drive bolt M6x8mm |
| 007267 | Zylinderschraube M10x45mm DIN912 10.9 | Allen Bolt M10x45mm DIN912 10.9 |
| 008152 | Pleuel inkl. Nadellager Ø28xØ22x20mm | Conrod c/w Needle Bearing Ø28xØ22x20mm |
| 008848 | Ölschleuderring | Oil Ring |
| 008849 | Ölrohr | Oil Pipe |
| 008852 | Anlaufscheibe Kurbelwelle | Thrust Washer |
| 009004 | Kurbelwellenlager (Schwungradseite) | Main Roller Bearing (Position: Flywheel Side) |
| 009005 | Kurbelwellenlager (Ölpumpenseite) | Main Roller Bearing (Position: Oil Pump Side) |
| 009055 | Kurbelwelle, komplett mit Gegengewicht und Schraube | Crankshaft c/w Counter Weight |

C

DETAILANSICHT / DETAILED VIEW

Kurbelwelle / Crankshaft

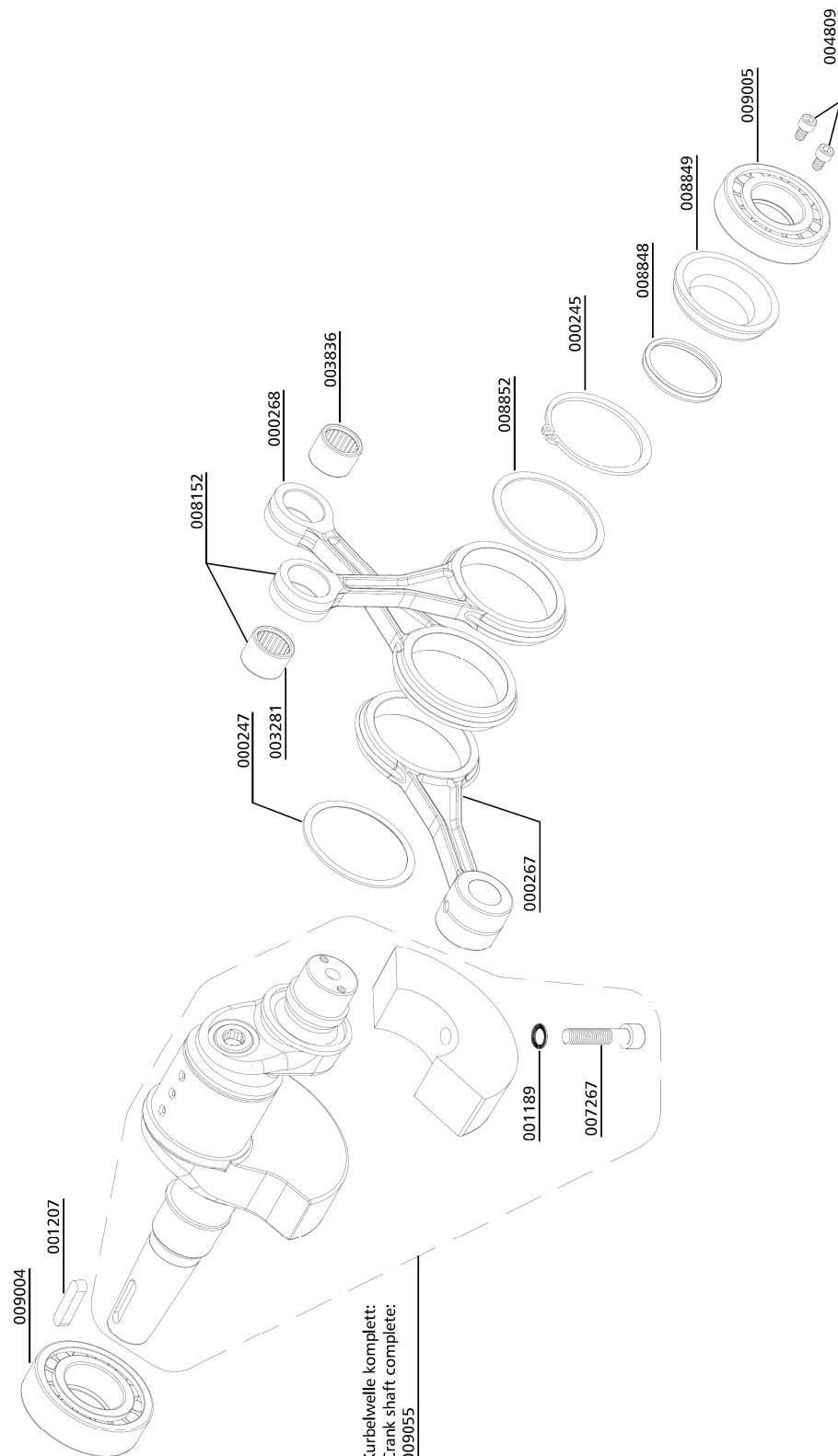

Kurbelwelle komplett:
Crank shaft complete:
009055





ERSATZTEILLISTE / SPARE PART LIST

Kolben 1. Stufe / Piston 1st Stage

| Best.-Nr. / Order No. | Benennung | Description |
|-----------------------|---------------------------------|---------------------------------|
| 000265 | Kolbenringsatz 1.Stufe, Ø 95mm | Piston Ring Set 3pcs |
| 000266 | Kolben komplett 1.Stufe, Ø 95mm | Piston complete 1.Stage, Ø 95mm |
| 001356 | Sicherungsring, I22 DIN472 | Circlip I22 DIN472 |
| 003900 | Kolbenbolzen 1.Stufe, Ø 22x85mm | Piston Pin, 1.Stage, Ø 22x85mm |

C

DETAILANSICHT / DETAILED VIEW

Kolben 1. Stufe / Piston 1st Stage

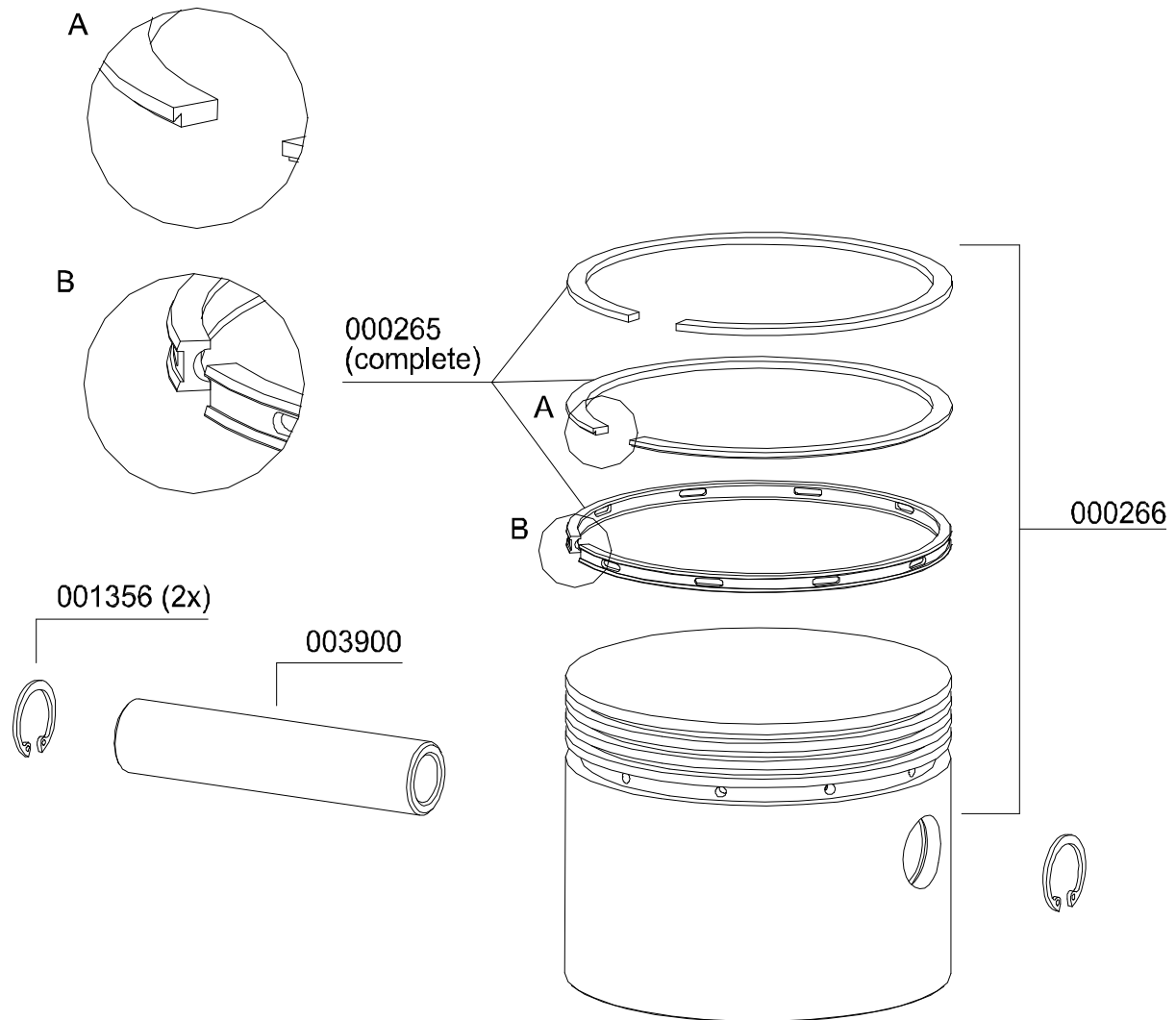



ERSATZTEILLISTE / SPARE PART LIST

Kolben 2. Stufe / Piston 2nd Stage

| Best.-Nr. / Order No. | Benennung | Description |
|-----------------------|--|--------------------------------------|
| 000263 | Kolbenringsatz 2.Stufe, 4 Stk.,Ø42 mm | Piston Ring Set 2.Stage, 4pcs, Ø42mm |
| 000264 | Kolben kompl. mit Kolbenringen, 2.Stufe, Ø42x70mm | Piston c/w Rings, 2.Stage, Ø42x70mm |
| 001002 | Kolbenbolzen 2. + 3.Stufe, Æ16x33mm | Piston Pin 2.+3.Stage, Æ16x33mm |
| 001353 | Sicherungsring, I 16 DIN472 | Circlip I 16 |

C

DETAILANSICHT / DETAILED VIEW

Kolben 2. Stufe / Piston 2nd Stage

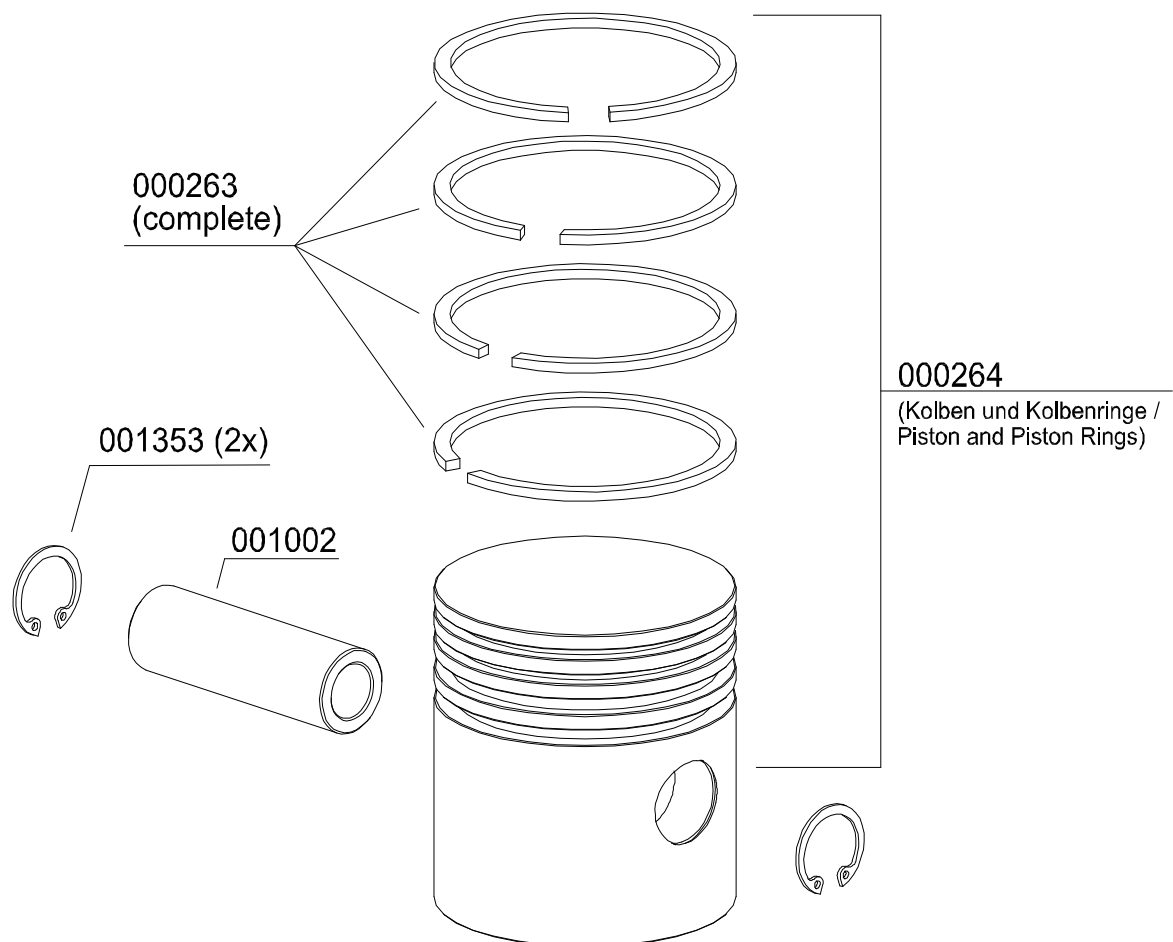



ERSATZTEILLISTE / SPARE PART LIST

Kolben 3. Stufe / Piston 3rd Stage

| Best.-Nr. / Order No. | Benennung | Description |
|-----------------------|---|--|
| 000373 | Kolbenbolzen Ø22 x 40 mm | Piston Pin Ø22 x 40 mm |
| 001356 | Sicherungsring, I 22 DIN472 | Circlip I 16 DIN472 |
| 002324 | Kolbenringsatz Ø18mm | Piston Rings Ø18mm |
| 003285 | Spezialwerkzeugsatz zur Kolbenring- u. Kolbenmontage | Special Tool Kit 3.Stage |
| 006904 | Kolben Piston Ø18mm/Ø50mm | Piston Ø18mm/Ø50mm |
| 008731 | Kolben Ø18mm/50mm mit Kolbenrin- gen, Kolbenbolzen u. Seegerringen | Piston Ø18mm/50mm c/w piston rings, piston pin and circlips |

C

DETAILANSICHT / DETAILED VIEW

Kolben 3. Stufe / Piston 3rd Stage

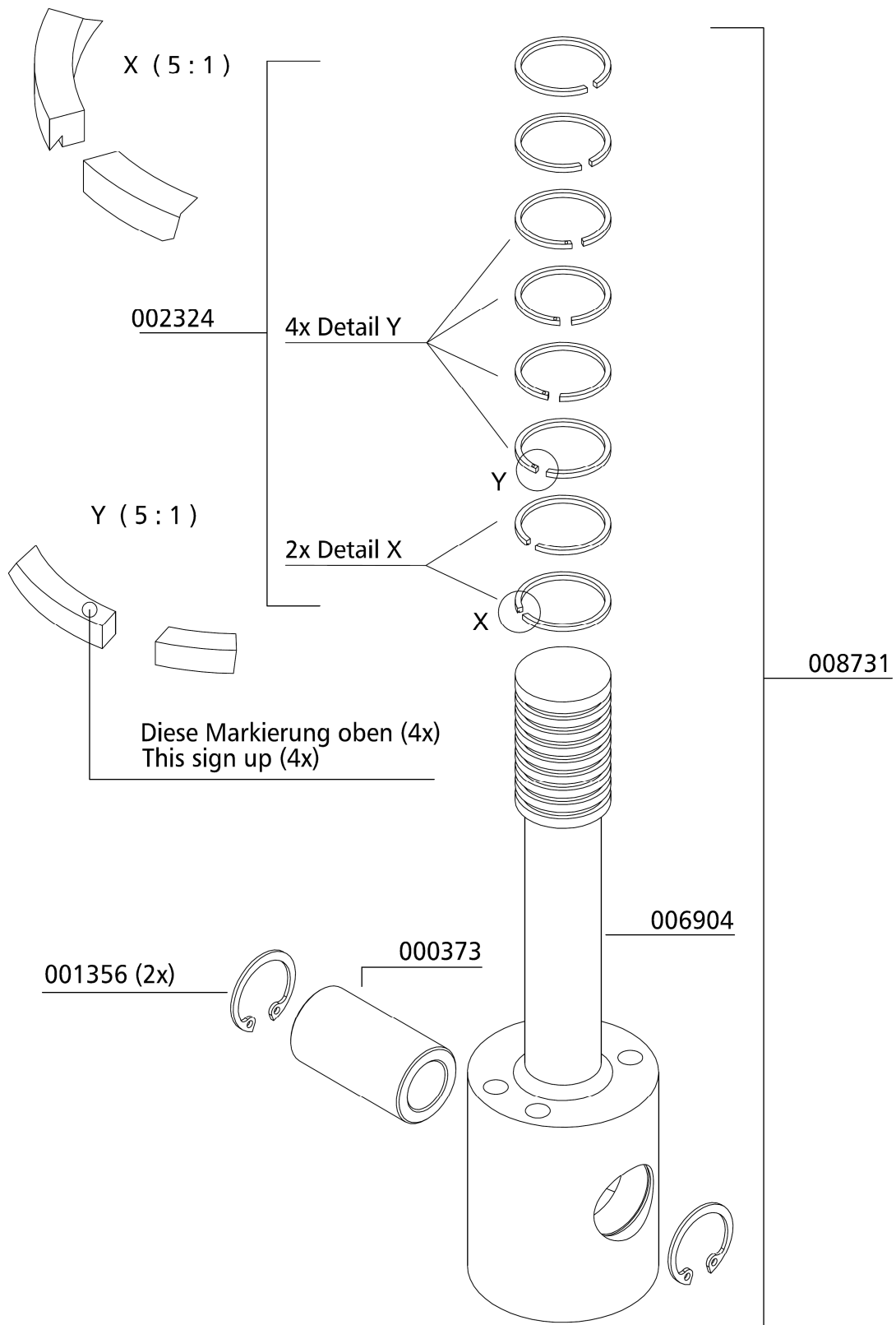

C

ERSATZTEILLISTE / SPARE PART LIST

Saug- und Druckventil 1. Stufe / In- and Outlet Valve 1st Stage

| Best.-Nr. / Order No. | Benennung | Description |
|-----------------------|-----------------------------|-----------------------------|
| 000259 | Saug- Druckventil, 1. Stufe | In-&Outlet Valve, 1st Stage |

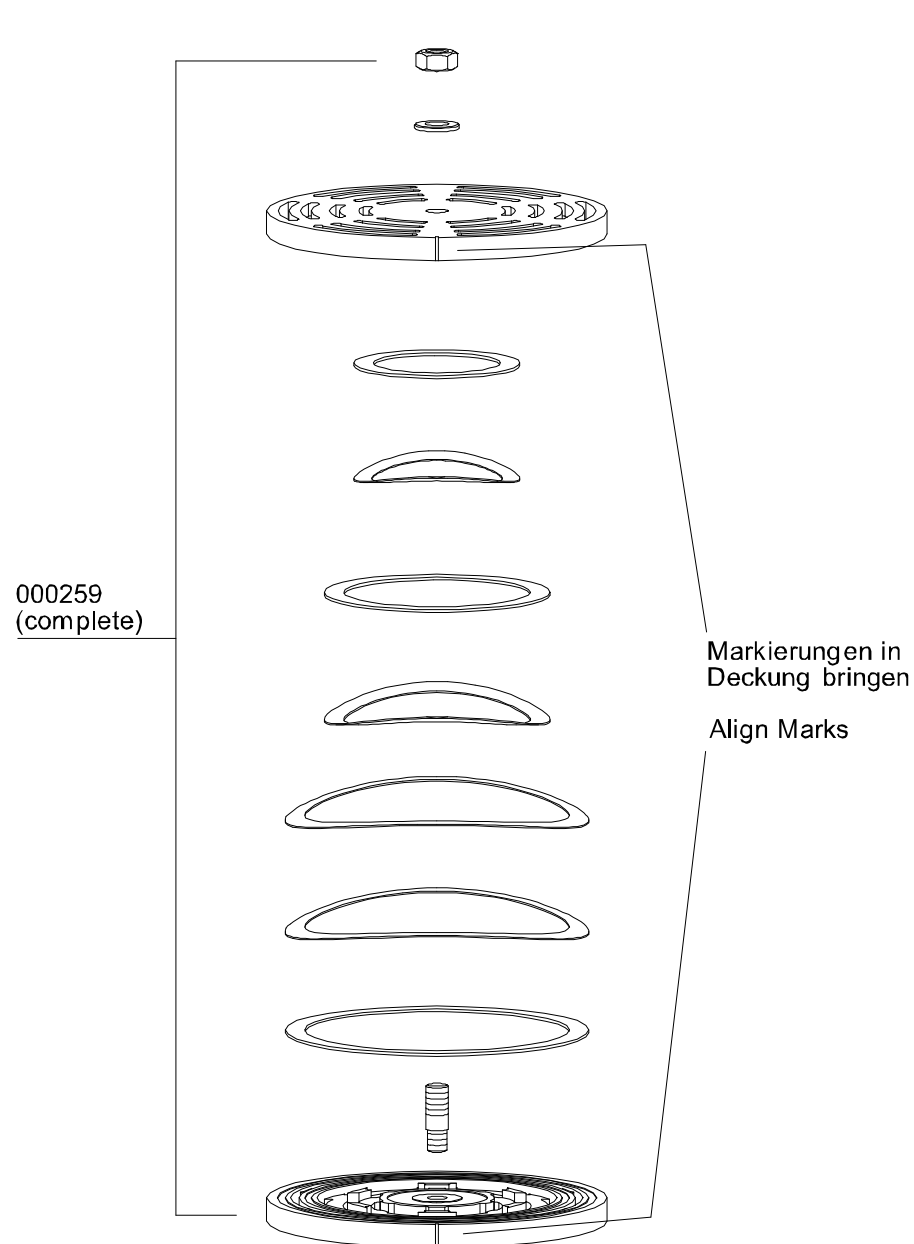

ERSATZTEILLISTE / SPARE PART LIST

Saug- und Druckventil 2. Stufe / In- and Outlet Valve 2nd Stage

| Best.-Nr. / Order No. | Benennung | Description |
|-----------------------|--------------------------------|-----------------------------------|
| 000256 | Saug- und Druckventil 2. Stufe | In- & Outlet Valve comp.2nd Stage |

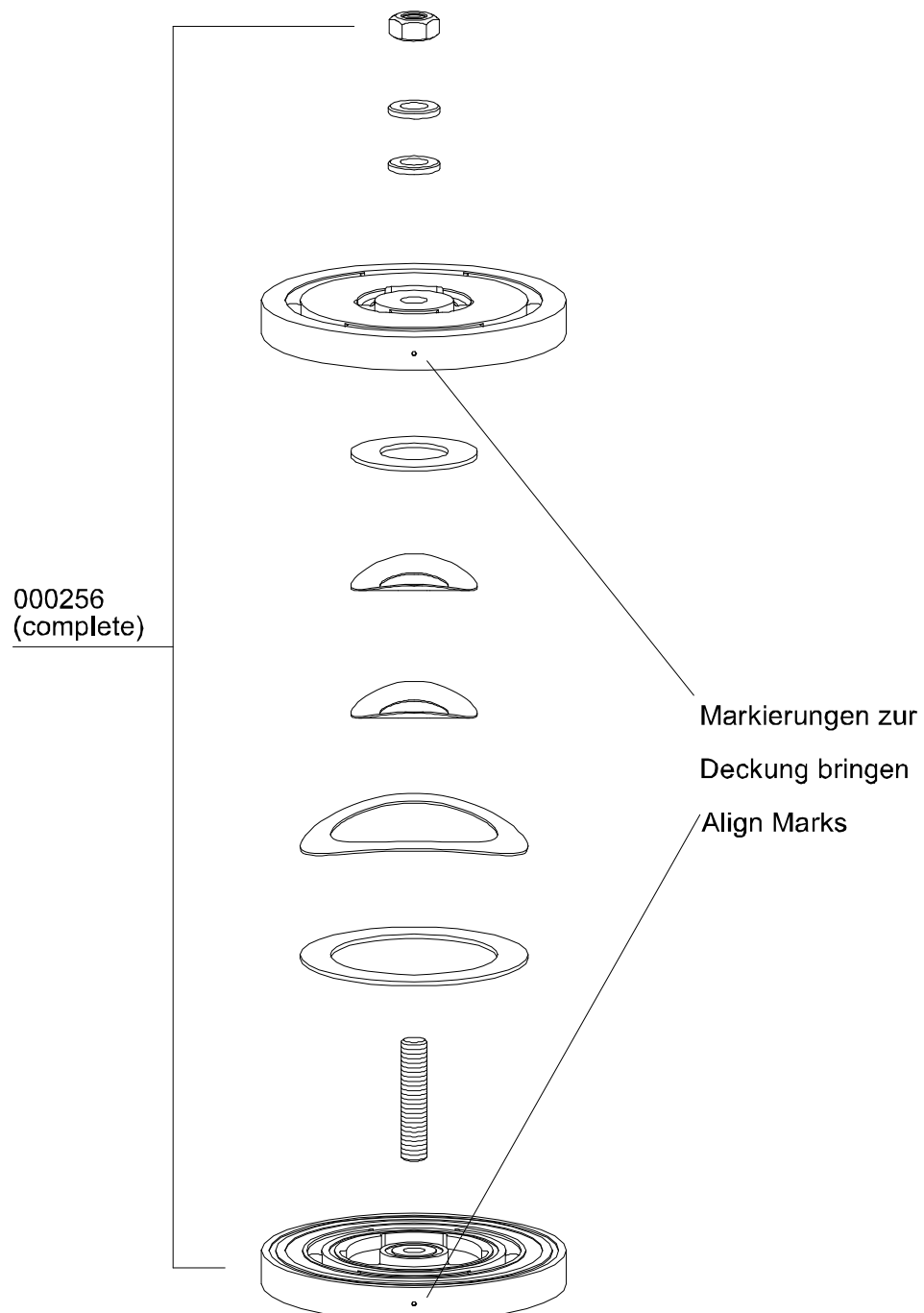

C



ERSATZTEILLISTE / SPARE PART LIST

Baugruppe: Ventil 3. Stufe / Assembly: Valve 3rd Stage

| Best.-Nr. / Order No. | Benennung | Description |
|-----------------------|--|---|
| 000525 | Saug-Druckventil, ohne Dichtungen, 4 x Ø3,0mm, ab Kompressorblock-Nr. 859 | In- & Outlet Valve, without gaskets, 4 x Ø3.0mm, from compressor block no. 859 |
| 000528 | Ventildichtung, Saug-& Druckventil unten | Lower Valve Gasket |
| 000540 | Dichtring / Dichtung , Saug- u. Druckventil oben, Alu | Upper Alloy Seal Ring |
| 000546 | Saug-Druckventil, ohne Dichtungen, 4 x Ø3,0mm, bis Kompressorblock-Nr. 858 | In- & Outlet Valve, without gaskets, 4 x Ø3.0mm, up to compressor block no. 858 |
| 010165 | Saug-Druckventil kompl. mit Dichtungen, bis Kompressorblock-Nr. 858 | In-& Outlet Valve c/w gaskets, up to compressor block no. 858 |
| 010337 | Saug-Druckventil kompl. mit Dichtungen, ab Kompressorblock-Nr. 859 | In-& Outlet Valve c/w gaskets, from compressor block no. 859 |

C

ERSATZTEILLISTE / SPARE PART LIST

Baugruppe: Ventil 3. Stufe / Assembly: Valve 3rd Stage

C

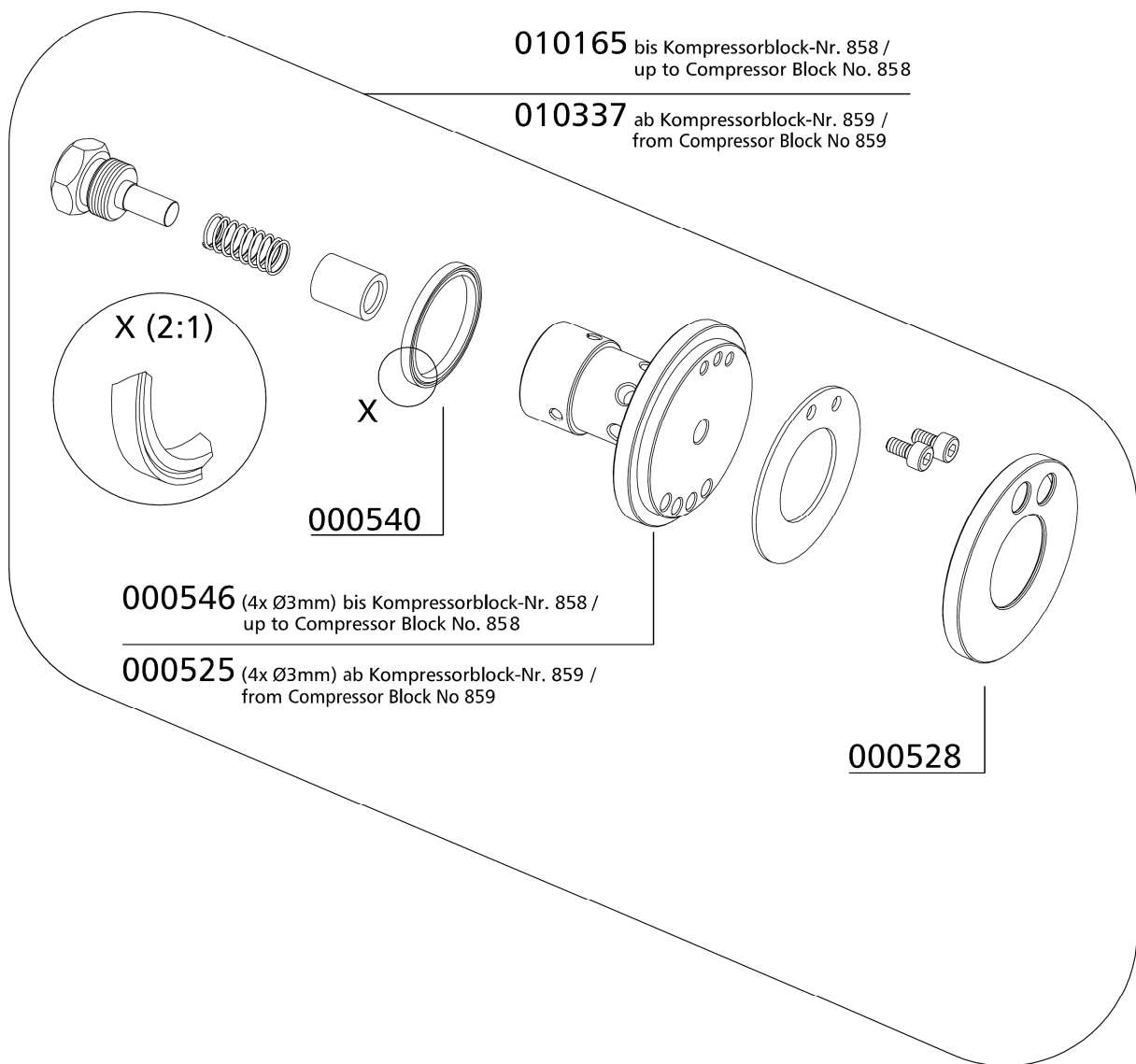



ERSATZTEILLISTE / SPARE PART LIST

Öl- und Wasserabscheider 1. Stufe / Oil- and Water Separator 1st Stage

| Best.-Nr. / Order No. | Benennung | Description |
|-----------------------|--|-------------------------------------|
| 000175 | Deckel, Wasserabscheider | Cover Water Separator |
| 000183 | Wasserabweiser | Filter Protector |
| 000184 | Sinterfilter Wasserabscheider | Sintered Filter, Oil Filter |
| 000185 | Halteteller | Plate |
| 000186 | Drallscheibe | Twist Disk |
| 000187 | Stiftschraube | Threaded Stud |
| 000562 | Wasserabscheider - Ring | Ring Water Separator |
| 000563 | Wasserabscheider - Behälter | Container Water Separator |
| 000820 | Verschraubung WE 15L RX | Elbow Connection |
| 000822 | Mutter 15L | Nut 15L |
| 000823 | Schneidring PSR 15 LX | Olive Seal 15mm |
| 000861 | Schneidring PSR 18 LX | Olive Seal 18mm |
| 000862 | Mutter M18L | Nut 18L |
| 000863 | Verschraubung WE 18L | Elbow Connection |
| 001133 | Sechskant Schraube M12x30mm DIN933 8.8 ZN | Hexagon Bolt M12x30mm DIN933 8.8 ZN |
| 001191 | U-Scheibe A12 DIN125 ZN | Washer A12 DIN125 ZN |
| 001192 | Federring A12 DIN 127 ZN | Spring Washer A12 DIN 127 ZN |
| 001272 | O-Ring Ø47 x 3 NBR70 | O-Ring Ø47 x 3 NBR70 |
| 001294 | O-Ring Ø68 x 3 NBR90 | O-Ring Ø68 x 3 NBR90 |
| 001431 | Befestigungsring Wasserabscheider | Lock Ring Water Separator |
| 002563 | Wasserabscheider Oberteil | Water Separator, Top |
| 003077 | Entwässerungsventil G1/4" AG | Drain valve G1/4" male |
| 006845 | Stopfmutter, Edelstahl, M6 DIN985 | Lock Nut, s/s, M6 DIN985 |

C

DETAILANSICHT / DETAILED VIEW

Öl- und Wasserabscheider 1. Stufe / Oil- and Water Separator 1st Stage

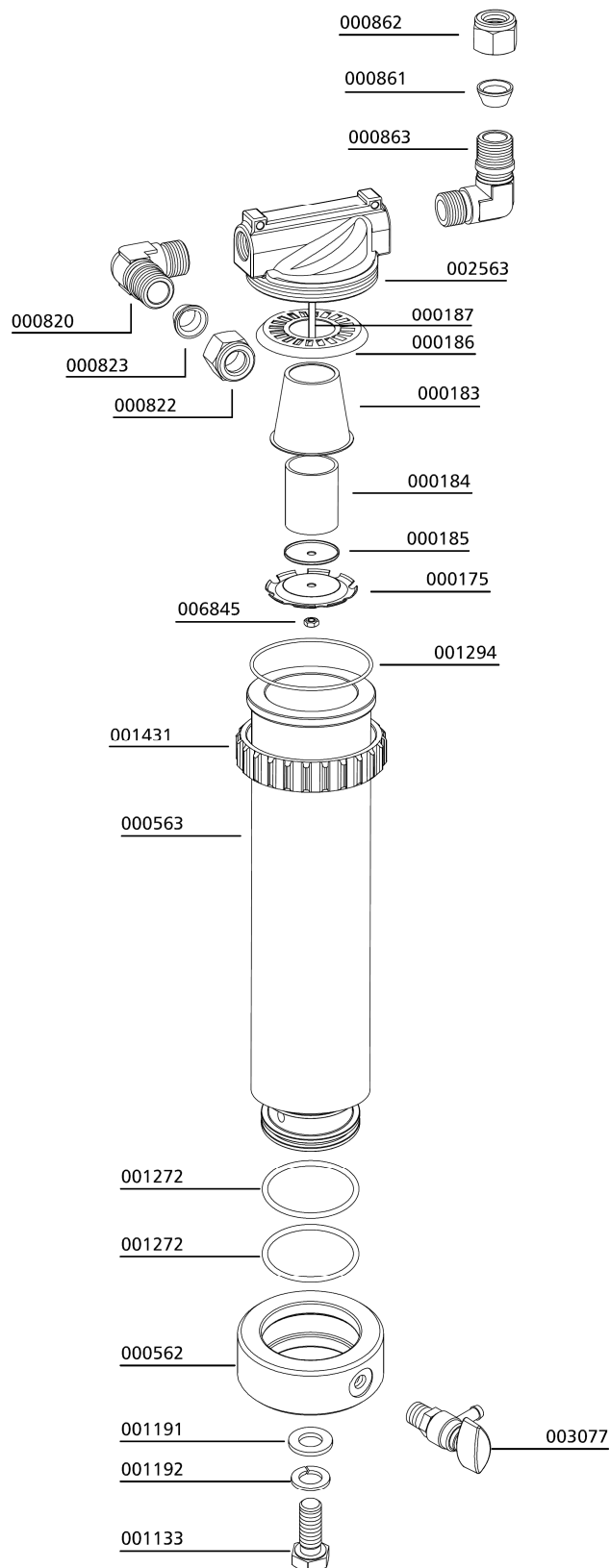

C



ERSATZTEILLISTE / SPARE PART LIST

Öl- / Wasserabscheider 2. Stufe / Oil- / Water Separator 2nd Stage

| Best.-Nr. / Order No. | Benennung | Description |
|-----------------------|--|-------------------------------|
| 000172 | Halteteller Wasserabscheider | Plastic Air Deflector |
| 000173 | Sinterfilter Wasserabscheider | Sintered Filter |
| 000174 | Drallscheibe, Wasserabscheider | Twist Disk |
| 000176 | Stiftschraube, Wasserabscheider | Treaded Stud |
| 000177 | Wasserabweiser, Wasserabscheider | Water Deflector, Plastic |
| 000379 | Wasserabscheider - Oberteil | Top ap Water Separator |
| 000562 | Wasserabscheider - Ring | Ring Water Separator |
| 000564 | Wasserabscheider – Behälter 2.Stufe LW450 | Container Water Separator |
| 000733 | Schneidring SR06 | Olive seal SR06 |
| 000758 | Verschraubung T 1/4" seitlich | T-connection with 1/4" radial |
| 000766 | Mutter L08 | Nut L08 |
| 000837 | Verschlussstopfen, VSTI R1/4"ED CFX | Plug |
| 000839 | Verschlussstopfen, VSTI R3/8"ED CFX | Plug |
| 000863 | Verschraubung | Elbow Connection |
| 000892 | Doppelnippel | Double nibble |
| 000921 | Reduzierung RI1/2X1/4CFX | Reducer RI1/2X1/4CFX |
| 001099 | 6-kant Schraube | Hexagon Screw |
| 001190 | Federring A10 | Spring Washer A10 |
| 001272 | O-Ring Wasserabscheider 47x3 NBR70 | O-Ring 47x3 |
| 003077 | Entwässerungsventil G1/4" AG | Drain valve G1/4" male |
| 006845 | Stopfmutter, Edelstahl, M6 DIN985 | Lock Nut, s/s, M6 DIN985 |

C

DETAILANSICHT / DETAILED VIEW

Öl- / Wasserabscheider 2. Stufe / Oil- / Water Separator 2nd Stage

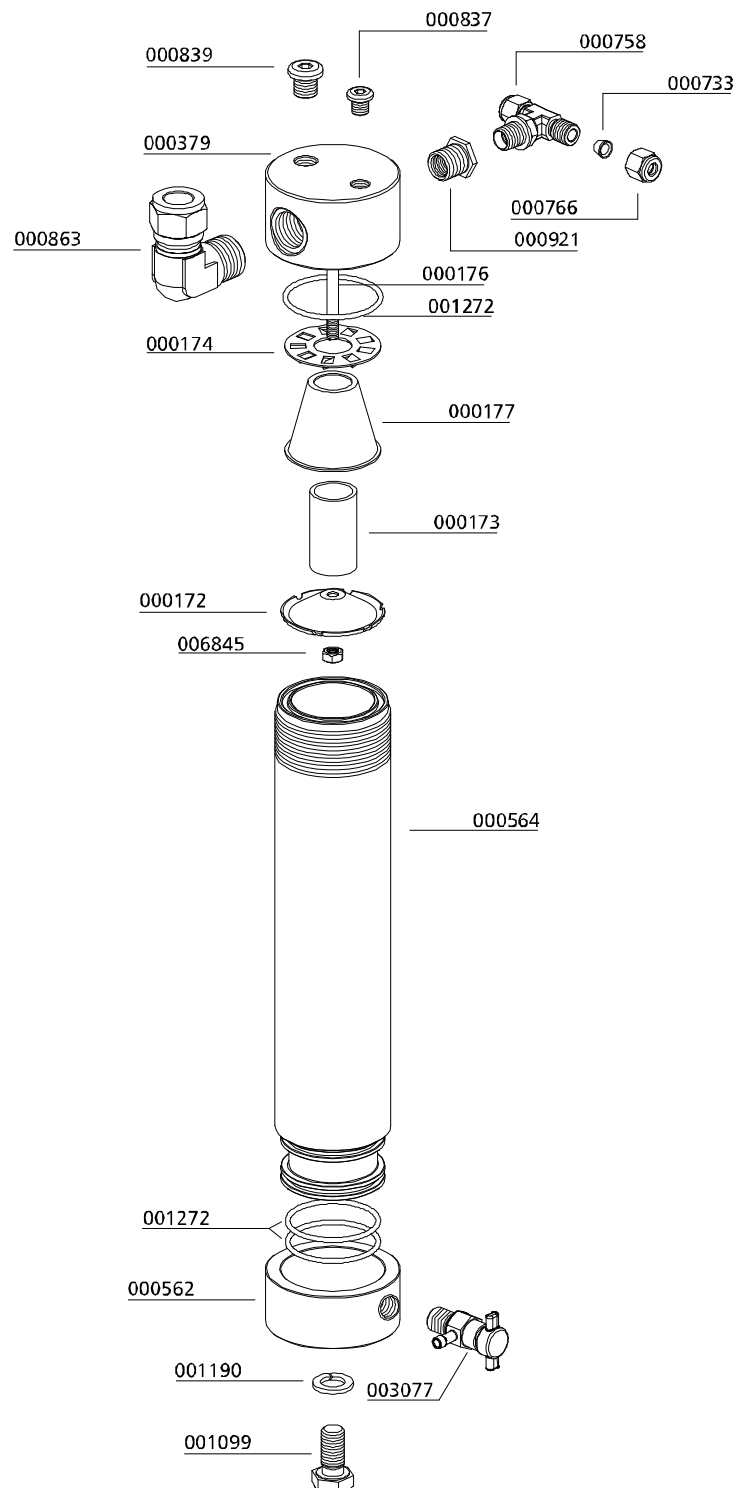

C

Filtergehäuse 1,7 l / Filter Housing 1.7 ltr

| Best.-Nr. / Order No. | Benennung | Description |
|-----------------------|---|---|
| 000002 | Filterpatrone 1,7 l | Filter Cartridge 1.7 ltr |
| 000272 | Abstandshalter für Filtergehäuse | Spacer Bracket for Filtertower |
| 000383 | Messing Adapter | Brass Filter Adapter |
| 000384 | Düse Filtergehäuse | Jet Filter Housing |
| 000761 | Winkerverschraubung, WE08L/1/4" | Elbow Connection, WE08L/1/4" |
| 000765 | Schneidring PSR 08 LX | Olive Seal PSR 08 LX |
| 000766 | Mutter M08LCFX | Union Nut M08LCFX |
| 001159 | Stopfmutter, M8 DIN985 ZN | Lock Nut, M8 DIN985 ZN |
| 001181 | U-Scheibe A8 DIN125 ZN | Washer A8 DIN125 ZN |
| 001285 | Stützring, 63,96x4,65 NBR90, 350 bar, Filtergehäuse | Back-up Ring, 63,96x4,65 NBR90, 350 bar, Filter Housing |
| 001287 | O-Ring, 62,87 x 5,33 NBR90, Filtergehäuse | O-Ring, 62,87 x 5,33 NBR90, filter housing |
| 002140 | Filterschlüssel 1,7 & 2,3 Liter Behälter | Filter tool 1,7 & 2,3 Litre |
| 002147 | Haltebügel für Filtergehäuse, beidseitig M8X35mm | Holder for filter housing, M8X35mm (both sides) |
| 002366 | Filtergehäuse, 1,7l | Filter housing 1.7ltr |
| 003077 | Entwässerungsventil G1/4" AG | Drain valve G1/4" male |
| 005244 | O-Ring, 16 x 2,5 NBR90 | O-Ring, 16 x 2,5 NBR90 |

C

DETAILANSICHT / DETAILED VIEW

Filtergehäuse 1,7 l / Filter Housing 1.7 ltr

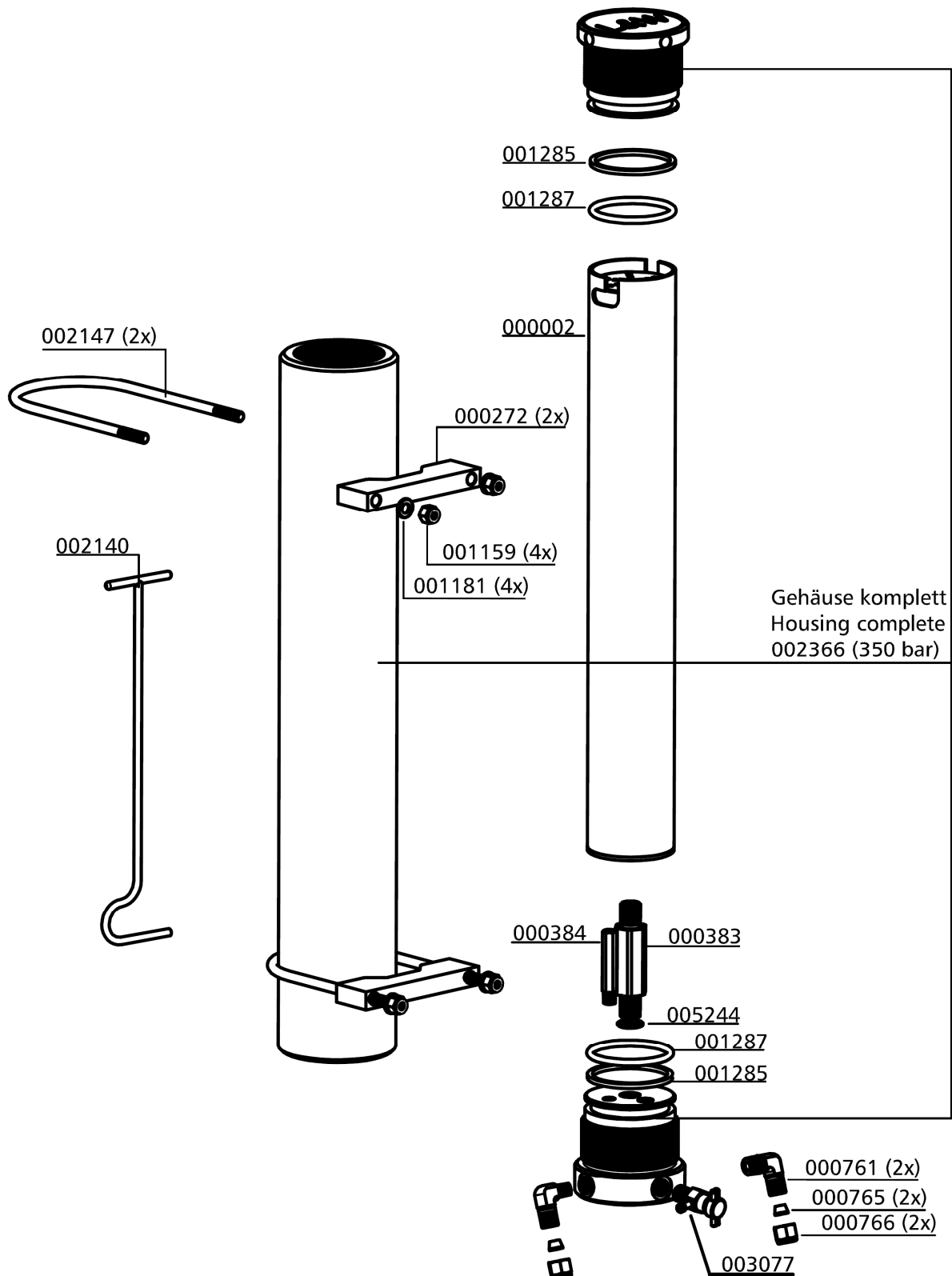

C



ERSATZTEILLISTE / SPARE PART LIST

Baugruppe: Kühler 1. Stufe / Assembly: Cooler 1st Stage

| Best.-Nr. / Order No. | Benennung | Description |
|-----------------------|--|---|
| 000568 | Halterung | Bracket |
| 001039 | Zylinderschraube | Allen Screw |
| 001058 | Zylinderschraube M8x70mm DIN912 8.8 ZN | Allen Bolt |
| 001159 | Stopfmutter | Lock Nut M8 |
| 001181 | U-Scheibe A8 DIN125 ZN | Washer A8 |
| 001205 | 4-kant Mutter | Square Nut M8 |
| 002106 | Distanzbolzen M8xSW14x53mm | Spacer bolt M8xSW14x53mm |
| 002995 | Wärmetauscher 1. u. 2. Stufe, inkl. Mutter & Schneidring | Heat Exchanger 1st & 2nd Stage, c/w nut & olive seal ring |
| 010303 | Klemmschiene Wärmetauscher, l=380mm | Metal clamp bar for cooler, l=380mm |
| 010863 | PVC Schlauch, transparent | PVC Hose for Bracket |

C

DETAILANSICHT / DETAILED VIEW

Baugruppe: Kühler 1. Stufe / Assembly: Cooler 1st Stage

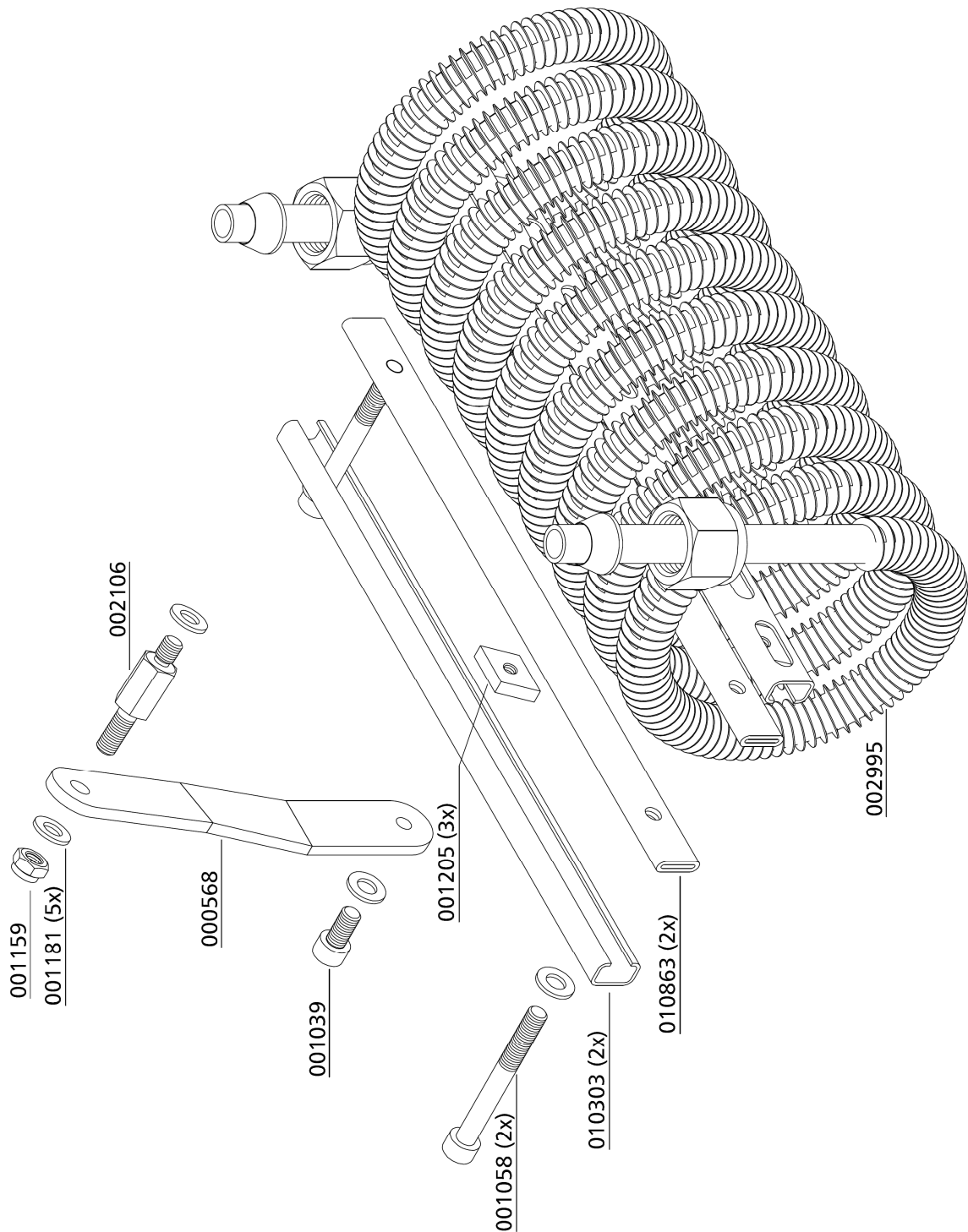

C



ERSATZTEILLISTE / SPARE PART LIST

Baugruppe: Kühler 2. Stufe / Assembly: Cooler 2nd Stage

| Best.-Nr. / Order No. | Benennung | Description |
|-----------------------|---|--|
| 000521 | Klemmschiene Wärmetauscher, l=340mm | Metal clamp bar for cooler, l=340mm |
| 000568 | Halterung | Bracket |
| 001039 | Zylinderschraube | Allen Screw |
| 001058 | Zylinderschraube M8x70mm DIN912 8.8 ZN | Allen Bolt |
| 001159 | Stopfmutter | Lock Nut M8 |
| 001181 | U-Scheibe A8 DIN125 ZN | Washer A8 |
| 001205 | 4-kant Mutter | Square Nut M8 |
| 002106 | Distanzbolzen M8xSW14x53mm | Spacer bolt M8xSW14x53mm |
| 002995 | Wärmetauscher 1. u. 2. Stufe, inkl. Mutter & Schneidring | Heat Exchanger 1st & 2nd Stage, c/w nut & olive seal ring |
| 010683 | PVC Schlauch, transparent | PVC Hose for Bracket |

C

DETAILANSICHT / DETAILED VIEW

Baugruppe: Kühler 2. Stufe / Assembly: Cooler 2nd Stage

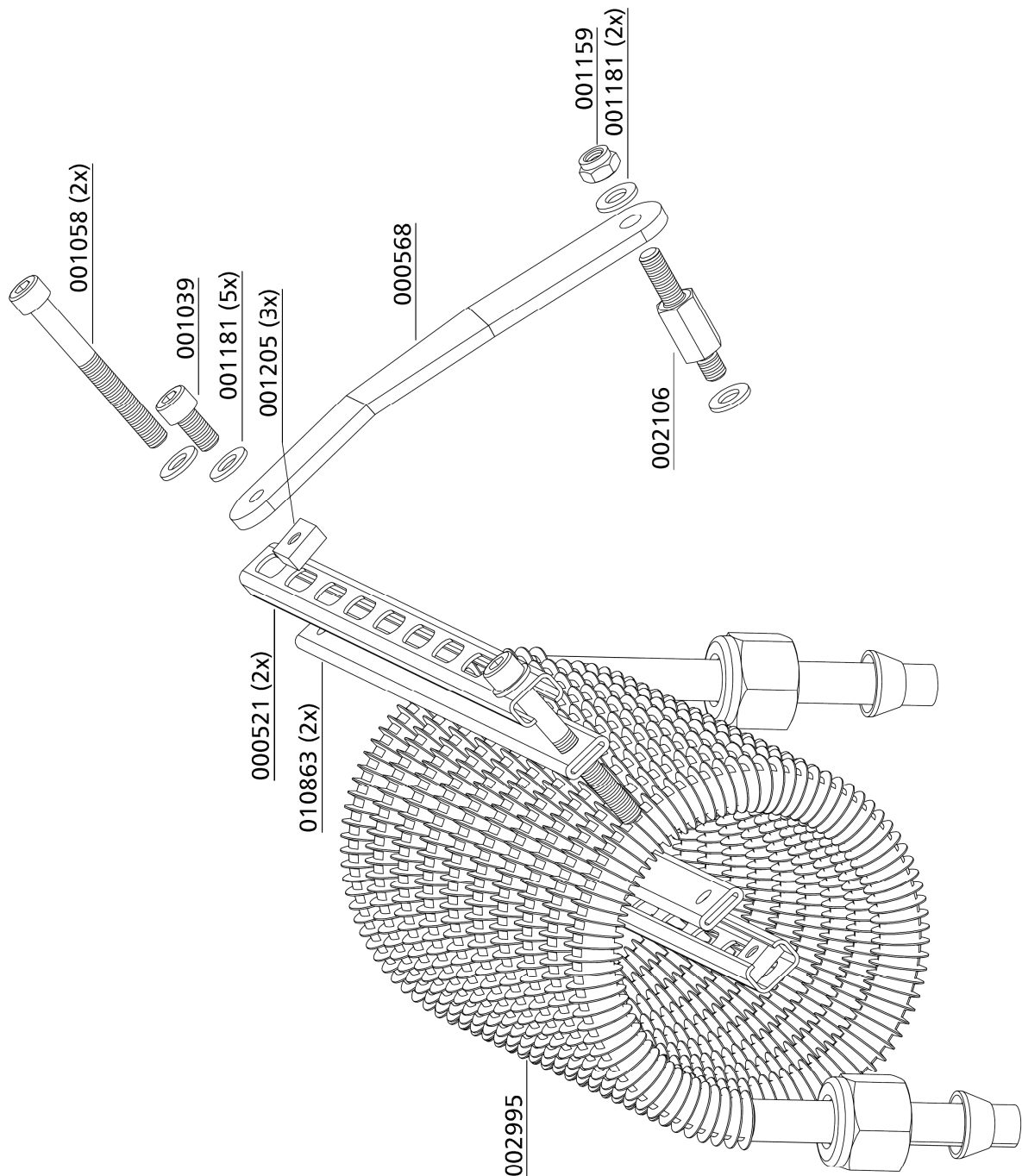

C



ERSATZTEILLISTE / SPARE PART LIST

Kühler 3. Stufe / Cooler 3rd Stage

| Best.-Nr. / Order No. | Benennung | Description |
|-----------------------|--|---------------------------------------|
| 000629 | Doppelschelle 2 x 8mm 1 Paar | Pipe Clamp 2x8mm - 1 pair |
| 000638 | Doppelschelle 2 x 8 mm 1 Paar | Pipe Clamp 2x8mm 1pair |
| 001026 | Zylinderschraube M6x40mm DIN912 8.8 ZN | Allen Bolt M6x40mm DIN912 8.8 ZN |
| 001028 | Zylinderschraube M6x25mm DIN912 8.8 ZN | Allen Bolt M6x25mm DIN912 8.8 ZN |
| 003224 | Kühlerhalteblech | Bracket, Cooler Stage 3 |
| 003225 | Kühlerhalteblech | Bracket, Cooler Stage 3 |
| 003226 | Kühlrohr 3te Stufe kompl. | Cooler, 3rd stage kompl. |
| 003574 | Kühlspirale komplett inkl. Haltearme | Cooling coil (complete) incl. bracket |

C

DETAILANSICHT / DETAILED VIEW

Kühler 3. Stufe / Cooler 3rd Stage

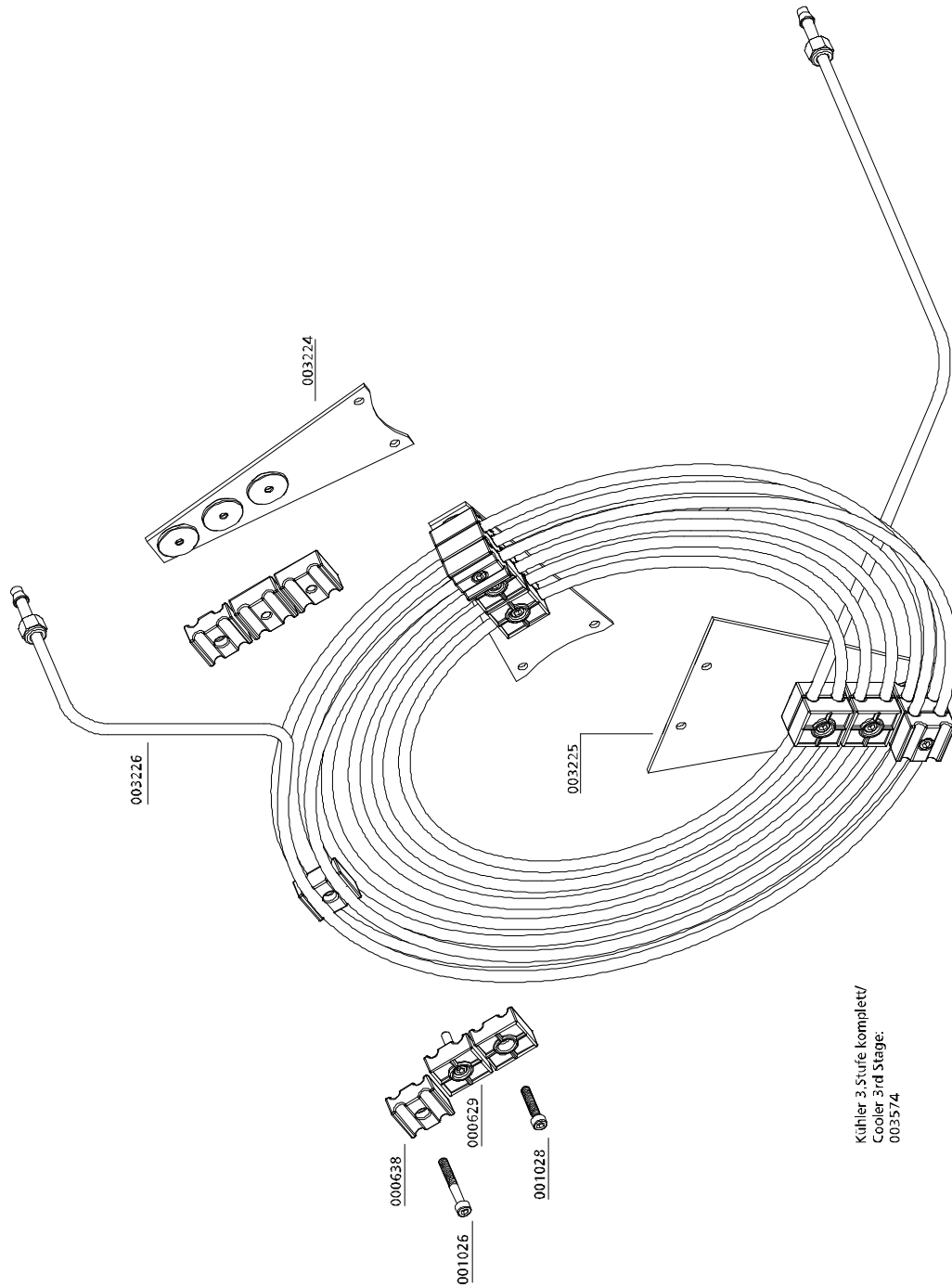



ERSATZTEILLISTE / SPARE PART LIST

Druckhalteventil / Pressure Maintaining Valve

| Best.-Nr. / Order No. | Benennung | Description |
|-----------------------|---|---------------------------------------|
| 000169 | Druckhalterückschlagventil, schwarz | Pressure Maint. Valve black |
| 000498 | U-Scheibe DIN 125 A6 | Washer DIN 125 A6 |
| 000506 | Feder | Spring |
| 000508 | USIT Ring 13,7 x Ø20 x 1,5 | Gasket Ring U-Sit 13,7 x Ø20 x 1,5 |
| 000511 | Mutter, Druckhalterückschlagventil | Lock Nut PMV |
| 000512 | Schraube, Druckhalte-Rückschlagventil | Set Bolt PMV |
| 000513 | Druckstück für Druckhalteventil, | Spring Adapter PMV, spring adapter |
| 000514 | Stift Druckhalte-/Rückschlagventil | Stud PMV |
| 000515 | Gehäuse, Druckhalte-Rückschlagventil | Main Body PMV |
| 000516 | Nutring, Druckhalterückschlagventil 5 x 10 x 5/2,5 90° Blau | Seal Ring PMV 5 x 10 x 5/2,5 90° blue |
| 000517 | Feder, Druckhalterückschlagventil | Coil Spring PMV |
| 000518 | Unterlegscheibe, Messing | Washer, Brass |
| 000519 | Dichtkappe, Druckhalte Rückschlagventil, schwarz | Plastic Seal Piston PMV, black |
| 000520 | Hohlschraube, DHRV | Inlet Jet PMV |
| 000765 | Schneidring PSR 08 LX | Olive Seal PSR 08 LX |
| 000767 | Mutter 08 S | Union Nut 08 S |
| 001023 | Zylinderschraube | Allen Bolt |

DETAILANSICHT / DETAILED VIEW

Druckhalteventil / Pressure Maintaining Valve

**Reparatursatz
003548:**

Bestehend aus:
Gelbmarkierte
Bestellnummern

**Repair kit
003548:**

Consists of:
Yellow marked
P/N's

000169 (complete)

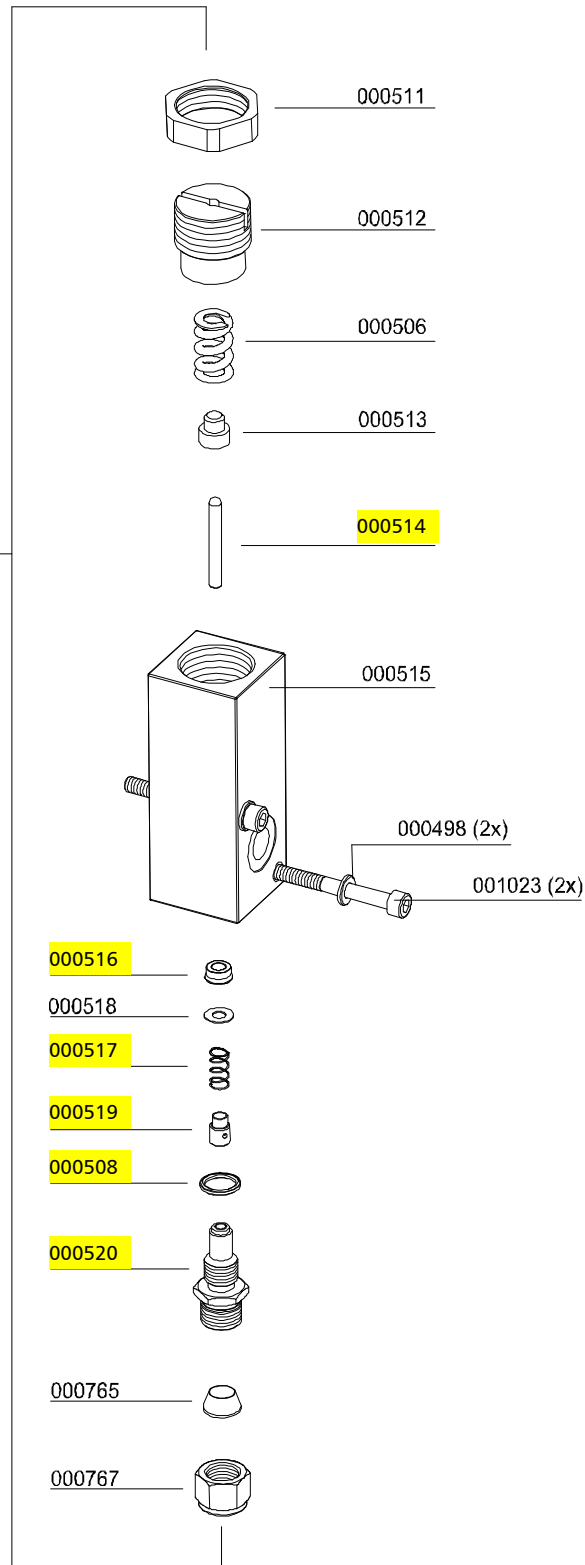

C



ERSATZTEILLISTE / SPARE PART LIST

Druckschalter / Pressure Switch

| Best.-Nr. / Order No. | Benennung | Description |
|-----------------------|---|---|
| 000203 | Druckschalter, G1/4" IG, PV 50 - 350 bar | Pressure Switch, G1/4" female 50-350 bar |
| 000216 | Halteklotz, Alu | Alloy Fixing Block, alloy |
| 000738 | Verschraubung, GE08LRFCX | Connection, GE08LRFCX |
| 000749 | Verschraubung mit fester Mutter, EVGE 08 PLR-ED | Connection with fixed nut, EVGE 08 PLR-ED |
| 000761 | Winkelverschraubung, WE08LRA3CX | Elbow Connection, WE08LRA3CX |
| 000765 | Schneidring, PSR 08 LX | Olive Seal, PSR 08 LX |
| 000766 | Mutter, M08LCFX | Nut, M08LCFX |
| 000783 | Verschraubung, GE10L - R1/4" | Straight Connection, GE10L - R1/4" |
| 000857 | Reduzierung mit fester Mutter, RED 08/06L | Reducer with fixed nut, RED 08/06L |
| 001026 | Zylinderschraube, M6x40mm DIN912 | Allen Bolt, M6x40mm DIN912 8.8 ZN |

C

DETAILANSICHT / DETAILED VIEW

Druckschalter / Pressure Switch

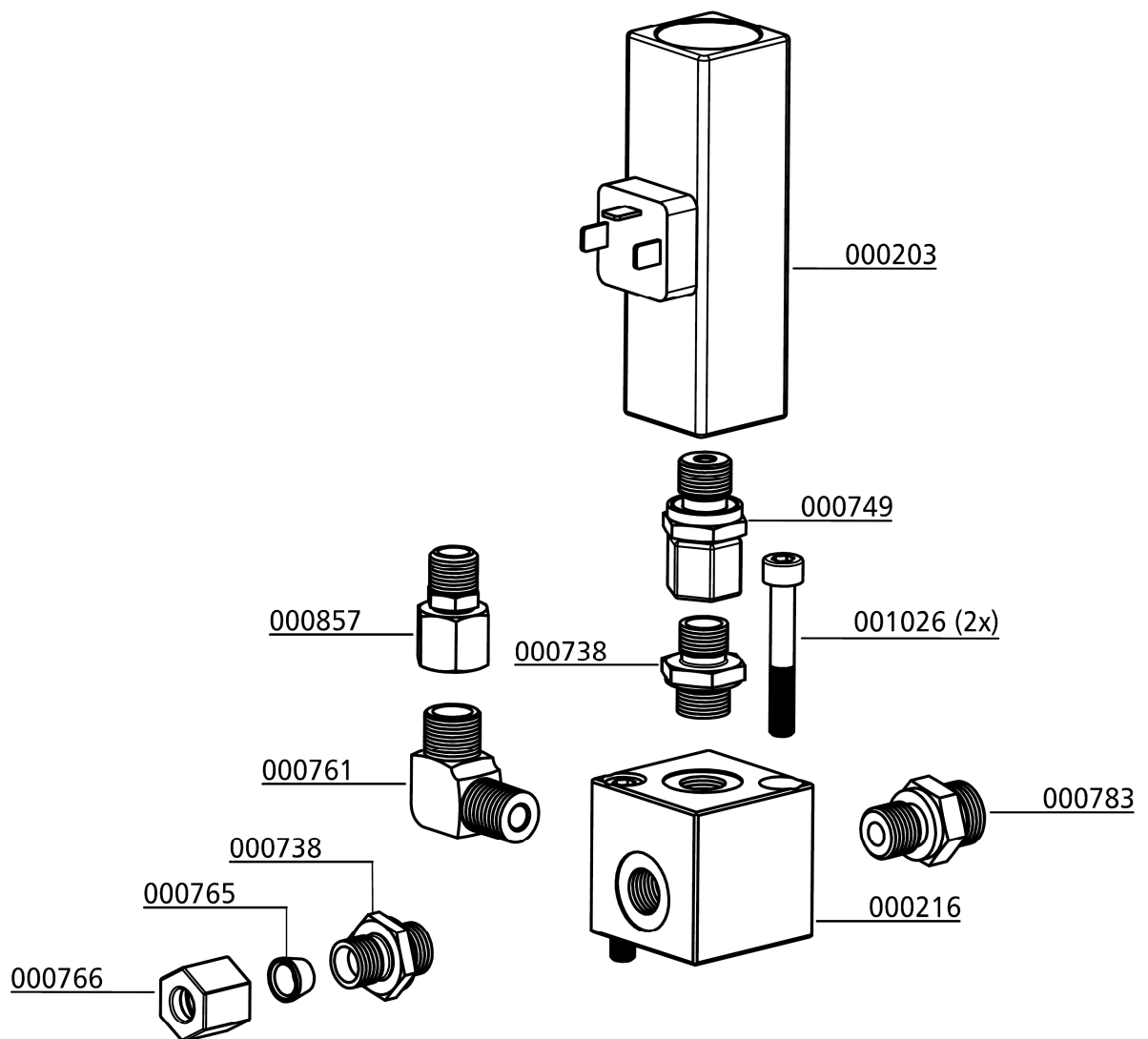

C



ERSATZTEILLISTE / SPARE PART LIST

Sicherheitsventil / Safety Valve

| Best.-Nr. / Order No. | Benennung | Description |
|-----------------------|---|--------------------------------|
| 000233 | Sockel für Sicherheitsventil mit TÜV, x G1/4" seitlich 180° | Base for Safety Valve TÜV type |
| 000553 | Sicherheitsventil 225bar mit TÜV | Safety Valve 225bar c/w TÜV |
| 000554 | Sicherheitsventil 250bar mit TÜV | Safety Valve 250bar c/w TÜV |
| 000555 | Sicherheitsventil 300bar mit TÜV | Safety Valve 300bar c/w TÜV |
| 000556 | Sicherheitsventil 330bar mit TÜV | Safety Valve 330bar c/w TÜV |
| 000557 | Sicherheitsventil 350bar mit TÜV | Safety Valve 350bar c/w TÜV |
| 000738 | Verschraubung GE08LRCFX | Connection GE08LRCFX |
| 000765 | Schneidring PSR 08 LX | Olive Seal PSR 08 LX |
| 000766 | Mutter M08LCFX | Nut M08LCFX |
| 000838 | Verschlussstopfen VSTIR1/4EDCF | Plug VSTIR1/4EDCF |
| 001044 | Zylinderschraube | Allen Bolt |
| 001058 | Zylinderschraube | Allen Bolt |
| 001158 | Mutter | Nut |
| 001181 | U-Scheibe | Washer |
| 001244 | O-Ring, Flansch Sicherheitsventil | O-Ring, Flange Safety Valve |
| 001814 | Sicherheitsventil 225bar mit CE | Safety Valve 225bar with CE |
| 001815 | Sicherheitsventil 250bar mit CE | Safety Valve 250bar with CE |
| 001816 | Sicherheitsventil 330bar mit CE | Safety Valve 330bar with CE |
| 001817 | Sicherheitsventil 350bar mit CE | Safety Valve 350bar with CE |

C

DETAILANSICHT / DETAILED VIEW

Sicherheitsventil / Safety Valve

| Druck/ Pressure | SV-Ventil mit CE-Prüfung/ Safety Valve with CE | SV-Ventil mit TÜV-Prüfung/ Safety Valve with TÜV |
|--------------------|---|---|
| 225 bar | 001814 | 000553 |
| 250 bar | 001815 | 000554 |
| 285/300 bar | ----- | 000555 |
| 330 bar | 001816 | 000556 |
| 350 bar | 001817 | 000557 |

Sonder-Einstelldrücke auf Anfrage! /
Special relieve pressures are available on request!

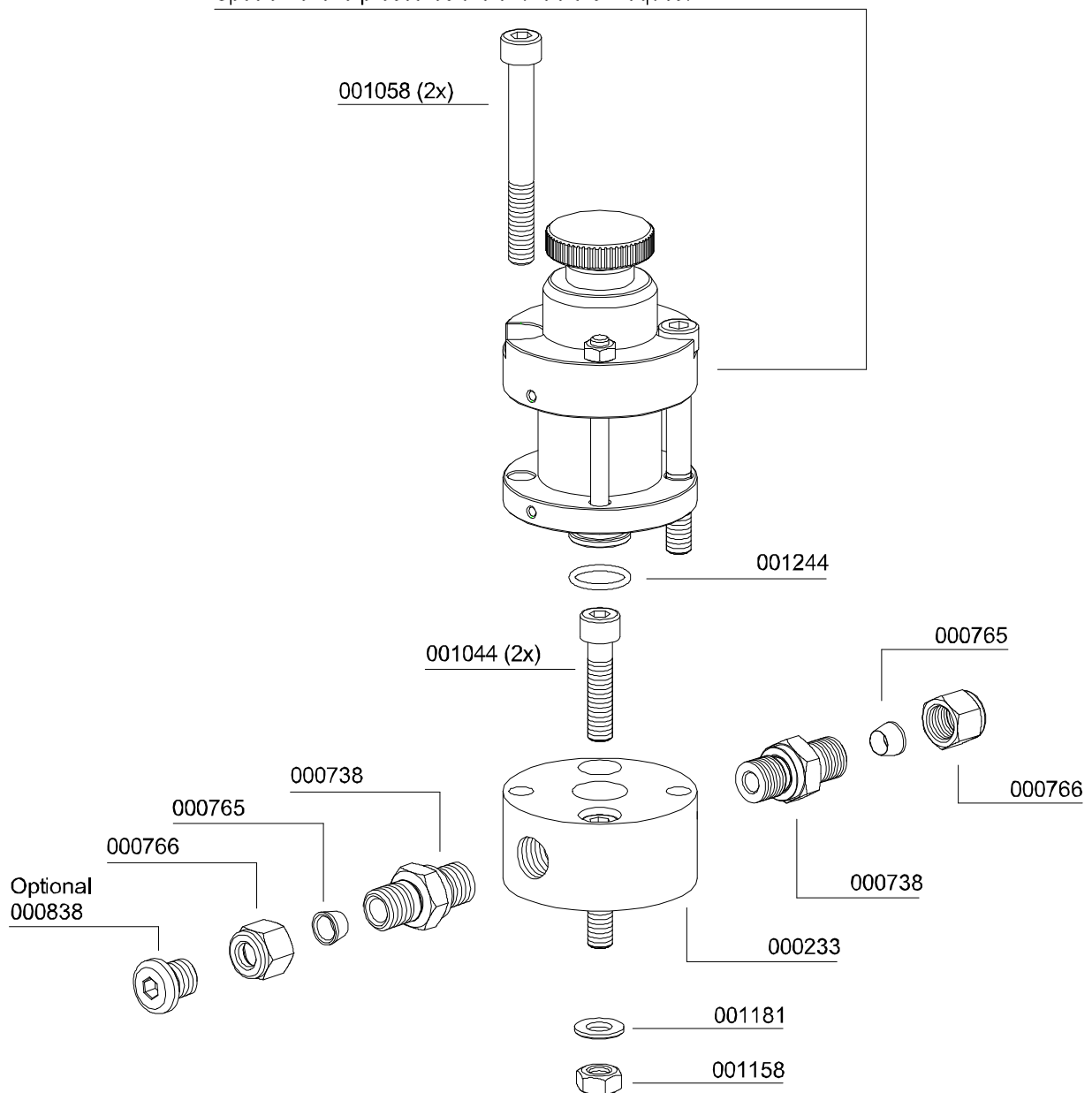

ERSATZTEILLISTE / SPARE PART LIST

Motor / Motor

| Best.-Nr. / Order No. | Benennung | Description |
|-----------------------|---|--|
| 001129 | Schlossschraube M12x40mm DIN603 8.8 ZN | Carriage Bolt M12x40mm DIN603 8.8 ZN |
| 001133 | Sechskantschraube M12x30mm DIN933 8.8 ZN | Hexagon Bolt M12x30mm DIN933 8.8 ZN |
| 001165 | Mutter M12 | Nut M12 |
| 001191 | U-Scheibe A12 | Washer A12 |
| 001192 | Federring A12 | Spring Washer A12 |
| 002872 | Antriebsmotor 11 kW 230 V 50/60 Hz | Drive motor 11kW 230V(50/60Hz) |
| 002974 | Antriebsmotor 11 kW / 400V 50/60Hz | Drive Motor 11kW 400V 50/60Hz |
| 002975 | Riemenscheibe TBA224-1, inkl. Spannbuchse | Pulley TBA224-1, c/w taper bush |
| 003172 | Schwungrad / Lüfterrad | Flywheel |
| 003175 | Passfeder (Motor) LW 300/450 | Woodruff Key (motor) |
| 004101 | Keilriemen XPA 2430 | V-belt XPA 2430 |
| 004291 | Antriebsmotor 7,5 kW / 400 V - 50/60 Hz | Motor 7,5kW, 400V, 50/60Hz |
| 004395 | Antriebsmotor 7,5kW / 230V / 50/60 Hz | Motor, 7,5kW, 230V, 50/60 Hz |
| 005122 | U-Scheibe Kurbelwelle | Washer, crank shaft |
| 005207 | Riemenscheibe SPA180-1, inkl. Spannbuchse | Pulley SPA180-1, c/w taper bush |
| 006465 | Riemenscheibe SPA190-1, inkl. Spannbuchse | Pulley SPA190-1, c/w taper bush |
| 007092 | Riemenscheibe TBA150-1, inkl. Spannbuchse | V-Belt Pulley TBA150-1, c/w inkl. taper bush |
| 009975 | Keilriemen SPA 2482 | V-Belt SPA 2482 |

C

DETAILANSICHT / DETAILED VIEW

Motor / Motor

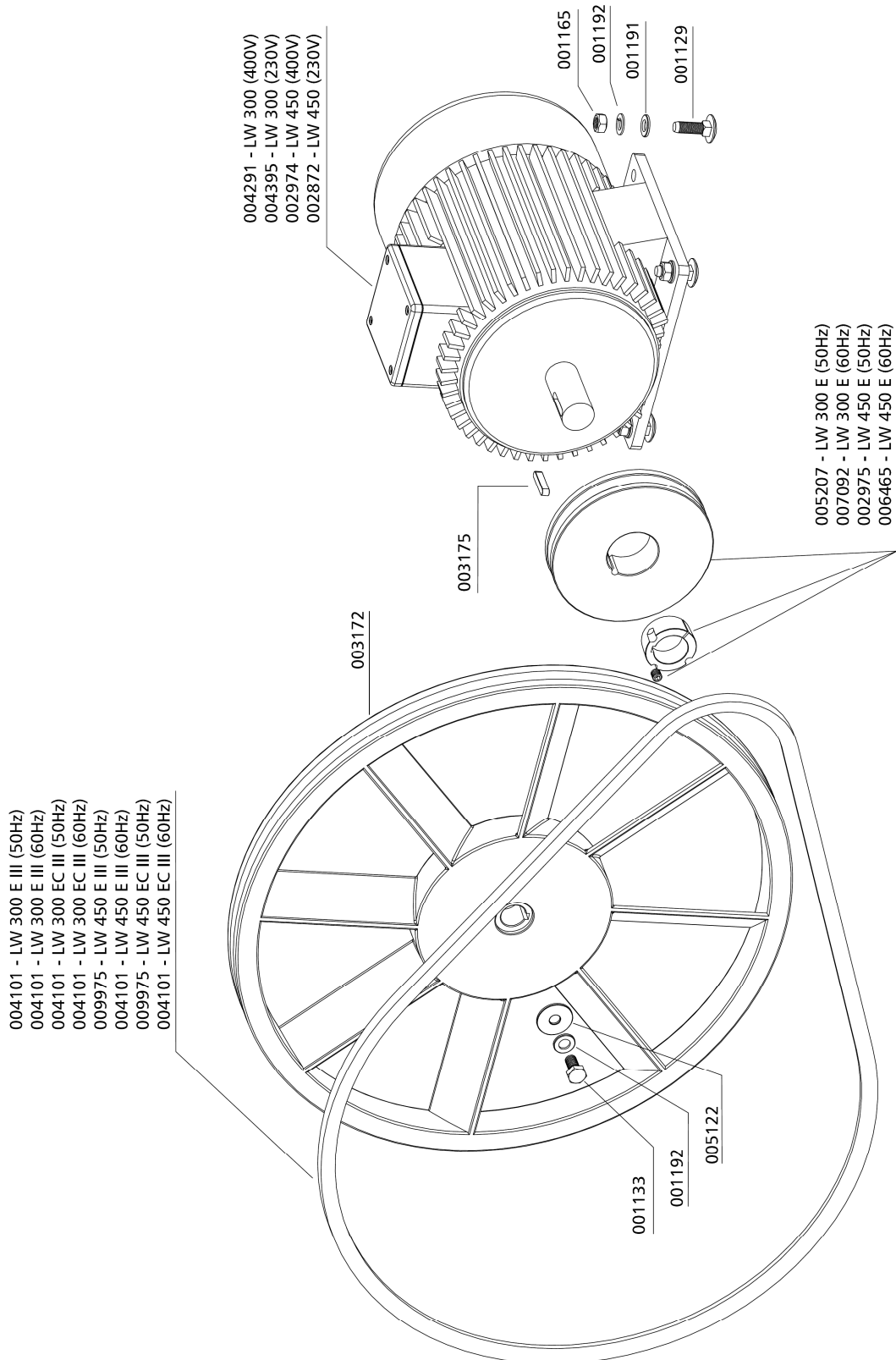



ERSATZTEILLISTE / SPARE PART LIST

Baugruppe: Ansaugfilter / Intake Filter

| Best.-Nr. / Order No. | Benennung | Description |
|-----------------------|-----------------------------|-------------------------------|
| 000170 | Ansaugfilterpatrone | Air Intake Filter Cartridge |
| 001772 | Flügelmutter, PVC-schwarz | Winged Nut, PVC black |
| 001782 | O-Ring, Ansaugfiltergehäuse | O-Ring, Intake Filter Housing |
| 009652 | Gehäuse für Ansaugfilter | Intake Filter Housing |
| 009653 | Deckel für Ansaugfilter | Cover Intake filter housing |
| 009658 | O-Ring | O-Ring |

C

DETAILANSICHT / DETAILED VIEW

Baugruppe: Ansaugfilter / Intake Filter

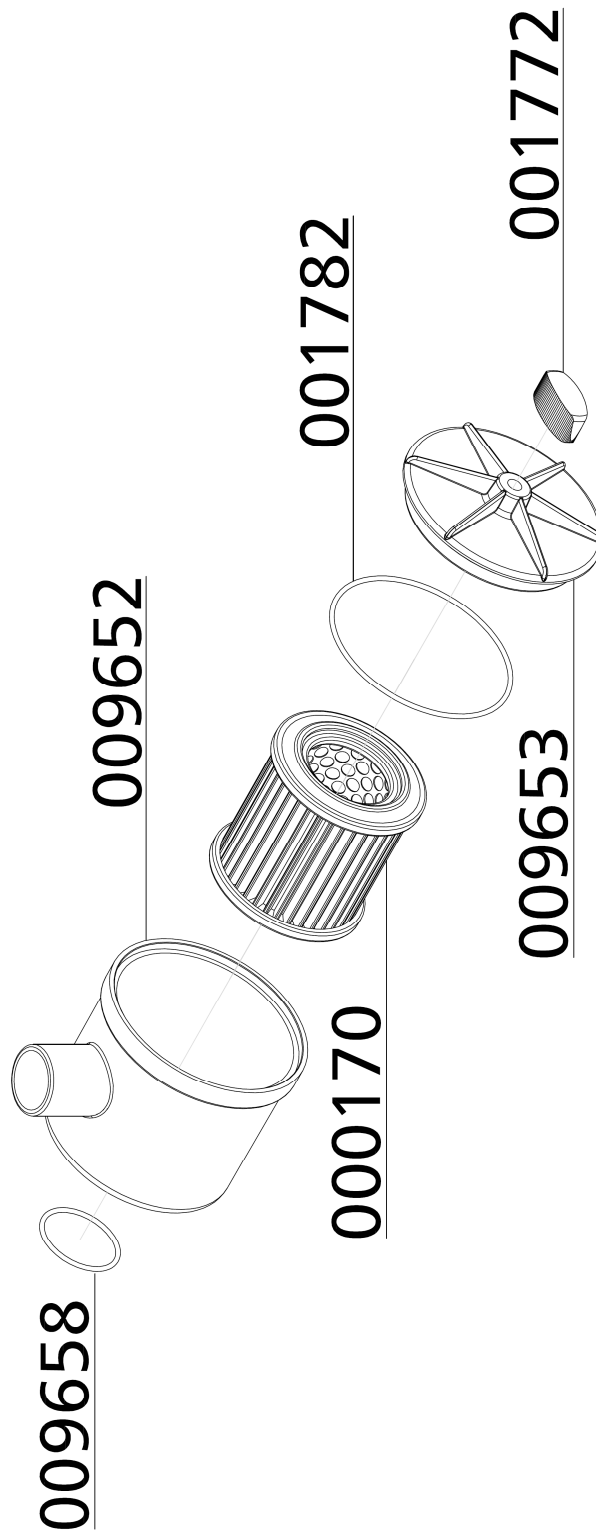

C

Ölpumpe / Oil Pump

| Best.-Nr. / Order No. | Benennung | Description |
|-----------------------|--|--------------------------------------|
| 000208 | Ölpumpenantriebsflansch | Drive Flange Oil Pump |
| 000498 | U-Scheibe DIN 125 A6 | Washer DIN 125 A6 |
| 000710 | Verschraubung GE06LRFCX | Connection GE06LRFCX |
| 000712 | Verschraubung GE06LR1/4CFX | Connection GE06LR1/4CFX |
| 000759 | Verschraubung WE 08 LL R 1/8" | Elbow connection WE 08 LL R 1/8" |
| 000761 | Winkelverschraubung WE08LRA3CX | Elbow Connection WE08LRA3CX |
| 000783 | Verschraubung GE10L - R1/4" | Straight Connection GE10L - R1/4" |
| 000837 | Verschlussstopfen VSTI R1/8" ED | Plug VSTI R1/8" ED |
| 000838 | Verschlussstopfen VSTIR1/4EDA3C | Plug VSTIR1/4EDA3C |
| 000895 | Doppelnippel G1/2" FF33MS | Double Nipple G1/2" FF33MS |
| 000921 | Reduzierung RI1/2X1/4CFX | Reducer RI1/2X1/4CFX |
| 000958 | Gewindestift M8x16mm DIN914, 5.8 ZN | Worm Screw M8x16mm DIN914 5.8 ZN |
| 001014 | Gewindestift mit Zapfen M6X14mm DIN915 | Allen Screw with Pin M6X14mm DIN915 |
| 001027 | Zylinderschraube M6x30mm DIN912 8.8 ZN | Allen Bolt M6x30mm DIN912 8.8 ZN |
| 001045 | Zylinderschraube M8x45mm DIN912 8.8 ZN | Allen Screw M8x45mm DIN912 8.8 ZN |
| 001159 | Stopfmutter M8 DIN985 ZN | Lock Nut M8 DIN985 ZN |
| 001181 | U-Scheibe A8 DIN125 ZN | Washer A8 DIN125 ZN |
| 002340 | O-Ring Ölpumpenflansch 32,2x3 NBR70 | O-Ring, oil pump flange 32,2x3 NBR70 |
| 008851 | Ölpumpenflansch | Oil Pump Flange |
| 008872 | O-Ring 72-2 NBR70 RX | O-Ring 72-2 NBR70 RX |
| 009183 | Halter Ölverteilerblock | Bracket oil distributor block |
| 009241 | Öldruckleitung Ø10mm, LW 450 / 530 / 570 | Oil Suction Pipe, LW 450 / 530 / 570 |
| 009242 | Öldruckleitung Ø8mm | Oil Suction Pipe Ø8mm |
| 009371 | Ölverteilerblock | Oil distributor block |
| 009445 | Niederdruckfilter, 10 bar | Low-Pressure Filter, 10 bar |
| 009446 | Anschraubpatrone | Screw on Cartridge |
| 009498 | Öldruckleitung Ø6mm | Oil Suction Pipe Ø6mm |
| 009500 | Öldruckleitung Ø6mm | Oil Pressure Pipe Ø6mm |
| 009610 | Ölpumpe | Oil Pump |

DETAILANSICHT / DETAILED VIEW

Ölpumpe / Oil Pump

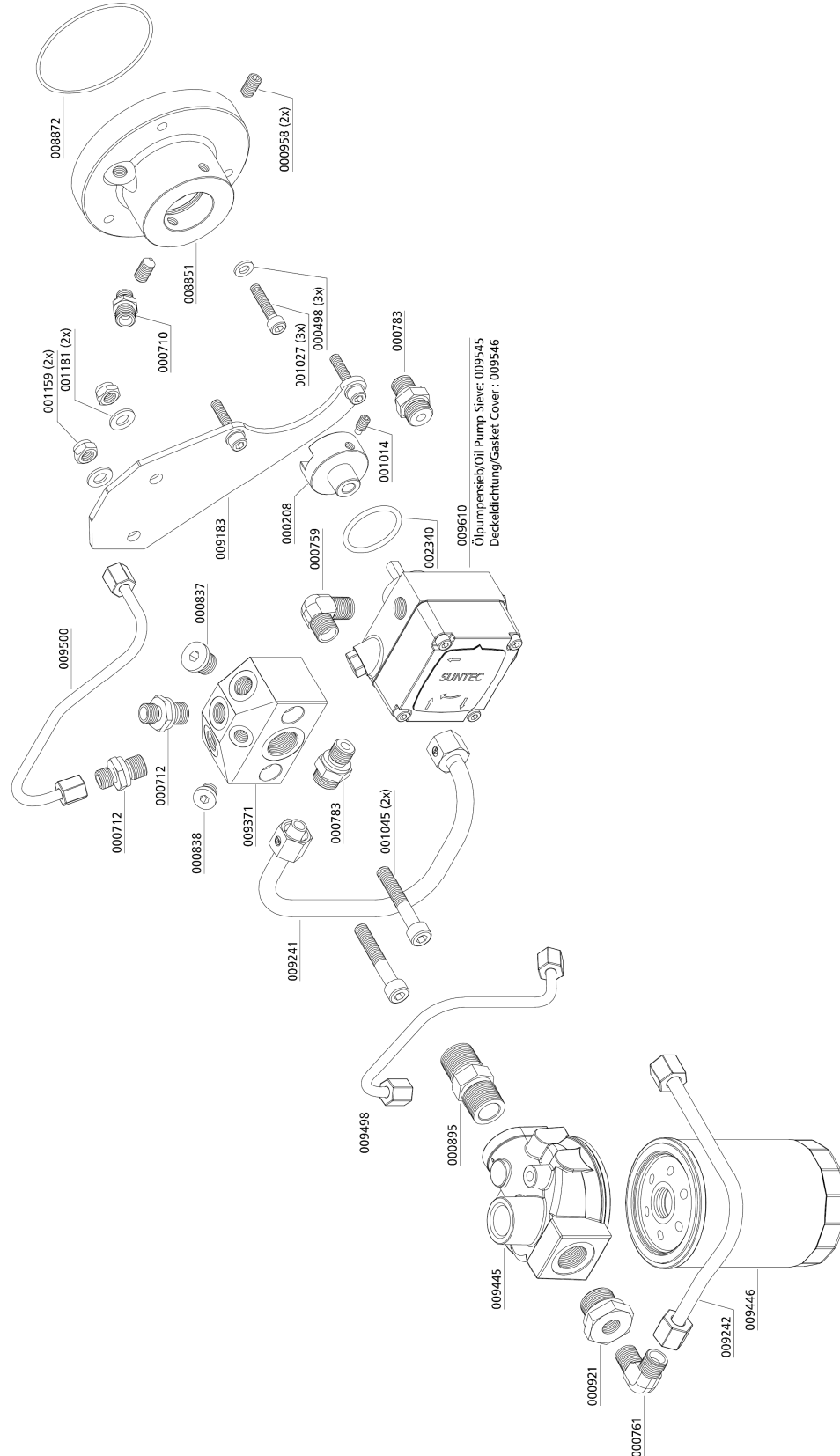

C



ERSATZTEILLISTE / SPARE PART LIST

Baugruppe: Ölablassschlauch / Assembly: Oil Drainage Tube

| Best.-Nr. / Order No. | Benennung | Description |
|-----------------------|--|---|
| 000817 | Verschraubung | Connection |
| 001548 | Ölablassventil (Kugelhahn) | Oil Drain Valve - ball valve |
| 002153 | Ölablassschlauch inkl. Kugelhahn | Oil drain hose c/w ball valve |
| 006417 | Ölablassschlauch | Oil drain hose |
| 008655 | Linsenflanschschraube mit Innensechskant M6x12 mm, DIN 7380F, 10.9 | Lens Head Screw M6x12 mm, DIN 7380F, 10.9 |
| 009772 | Halter Öl-Ablausschlauch | Holder Oil drain hose |

C

DETAILANSICHT / DETAILED VIEW

Baugruppe: Ölablassschlauch / Assembly: Oil Drainage Tube

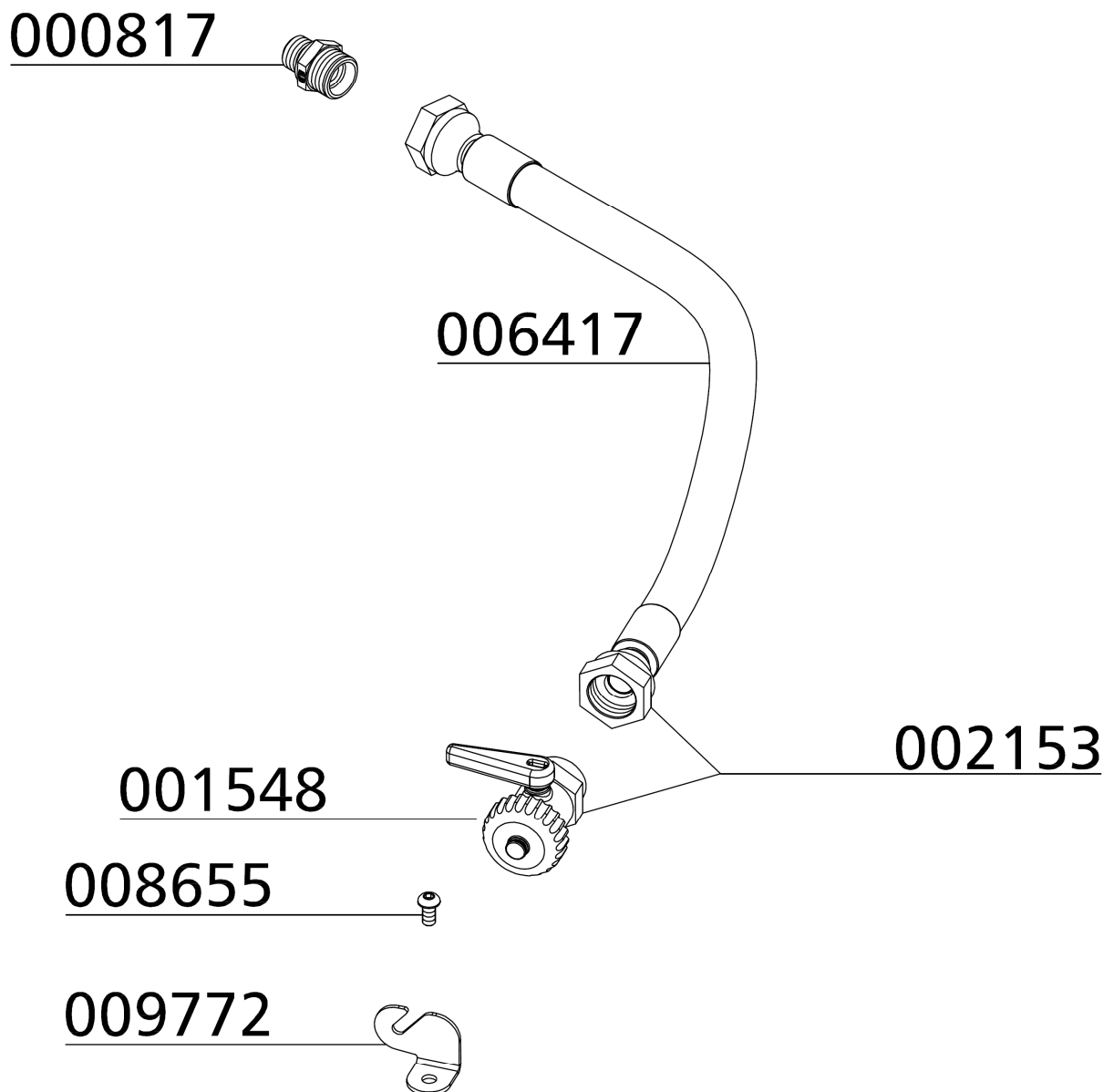

C



OPTIONS



Table of Contents

| | |
|---|----|
| Auto Shut Down..... | 1 |
| Automatic Condensation Drain..... | 6 |
| Auto Start Function..... | 39 |
| Oil Pressure Gauge | 45 |
| Oil Pressure Monitoring | 48 |
| Oil Temperature Monitoring | 54 |
| Cylinder Head Temperature Monitoring | 57 |
| Interstage Pressure Gauges..... | 60 |
| 200+300bar Parallel Filling Pressure Operation..... | 63 |
| Air Cooler Connection Kit..... | 70 |
| Condensate Tank 60L | 73 |



AUTO SHUT DOWN

D

AUTO SHUT DOWN

Final pressure switch

The pressure switch shuts off the compressor automatically when the selected final pressure is reached. The final pressure switch is already adjusted to the corresponding cut-out pressure.

The pressure can be adjusted with the upper adjusting screw as follows:

Increasing cut-out pressure:

Turn the adjusting screw clockwise

Reducing cut-out pressure:

Turn the adjusting screw anti-clockwise

Adjust the pressure switch in steps of a quarter turn.

Restart the compressor after every adjustment step to verify the actual cut-out pressure.

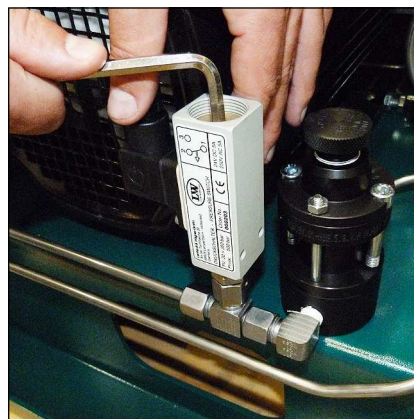

Final pressure switch

D



Note

Do not adjust the final pressure switch to the safety valve pressure. The final pressure switch has to be adjusted to min. 10 bar below the safety valve pressure. Otherwise, the safety valve can open during operation. This considerably reduces the life of the safety valve.

Example settings:

| Safety valve | Max. Operating Pressure |
|--------------|-------------------------|
| 225 bar | 215 bar |
| 250 bar | 240 bar |
| 330 bar | 320 bar |

AUTO SHUT DOWN

Safety valve test



Note

Do not fill any tank during test phase!

Safety valve test as follows:

- Disconnect compressor from the electrical power supply and protect against unexpected restart.
- Remove the cover of the switch box.
- Switch on the "Test Safety Valve" switch (pressure switch will be deactivated!).
- Mount the cover of the switch box.
- Connect the compressor to the electrical power supply.
- Close filling valves.
- Start the compressor.
- Watch the final pressure gauge. The safety valve should open when reaching working pressure of the compressor. If not, switch off the unit and take out of service until the safety valve has been replaced.
- Switch off the compressor (compressor vented).
- Disconnect the compressor from the electrical power supply and protect against unexpected restart.
- Remove the cover of the switch box.
- Switch off the "Test Safety Valve" switch (pressure switch will be activated!).
- Mount the cover of the switch box.
- Connect the compressor to the electrical power supply.

The safety valve test is now completed.

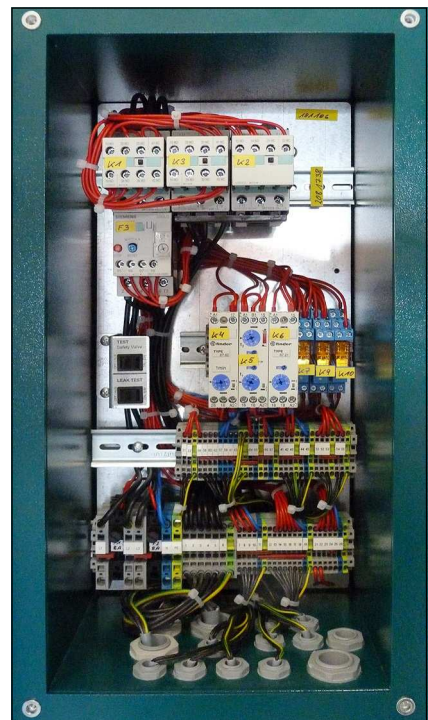

Switch box

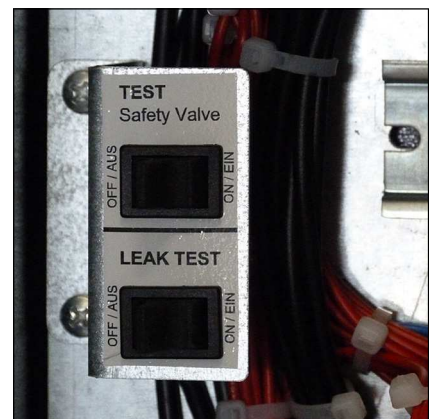

Safety valve test switch (up)



AUTO SHUT DOWN

Druckschalter / Pressure Switch

| Best.-Nr. / Order No. | Benennung | Description |
|-----------------------|---|-------------------------------------|
| 000203 | Druckschalter 50-350 bar | Pressure Switch 50-350 bar |
| 000749 | Verschraubung, mit fester Mutter | Connection with fixed nut |
| 000757 | T-Verschraubung mit fester Mutter seitl. EL 08 L | T-Connection with fixed nut EL 08 L |
| 000765 | Schneidring PSR 08 LX | Olive Seal PSR 08 LX |
| 000766 | Mutter 08L CFX | Nut 08L CFX |

D

AUTO SHUT DOWN

Druckschalter / Pressure Switch

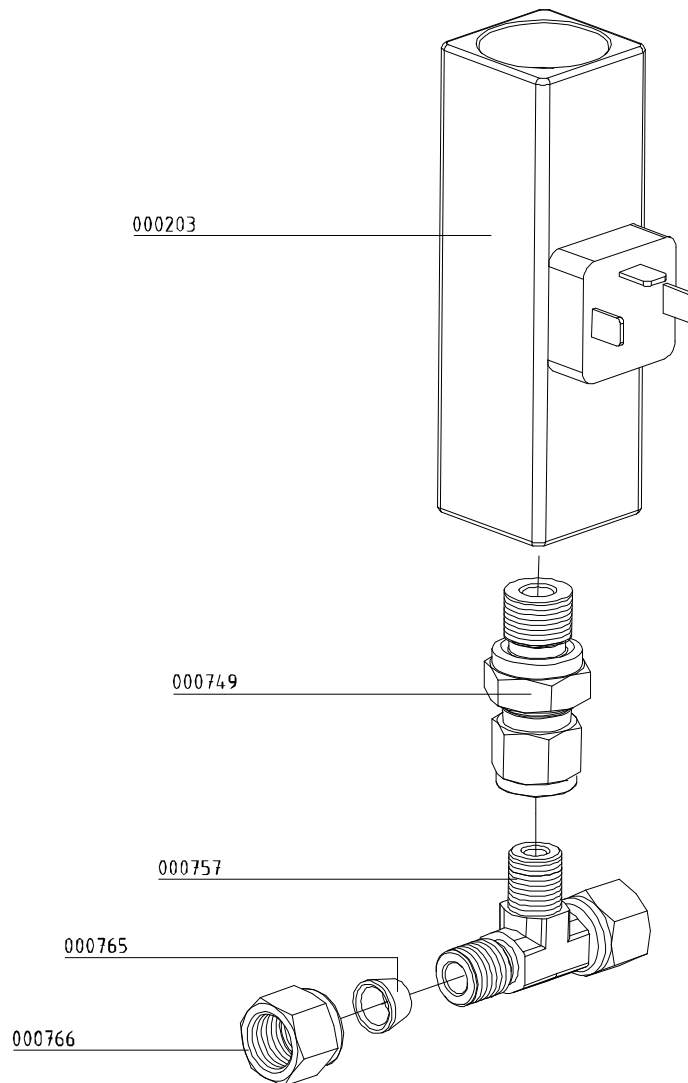

D



AUTOMATIC CONDENSATION DRAIN

D

AUTOMATIC CONDENSATION DRAIN

Automatic condensation dump system



Note

The collected condensate can contain oil and has to be disposed according to regulations.

The LW 450 E Compact III is optional with an automatic condensation dump system available. Solenoids drain all condensate separators every 15 minutes.

To test the system, press the blue condensate test drain button on the operating panel.

Oil / water separators

Condensate is separated after every stage of compression. All three oil / water separators are equipped with electronic timer controlled solenoids. The timer is located in the switch box and activates the dump valves about every 15 minutes.

The condensate drains through the black plastic hoses into the 10 liter condensate catch tank.

The drain noise can be kept to a minimum by using a silencer.

Maintenance intervals

We recommend to clean oil and water separators every 500 operating hours or at least once a year, to check for corrosion damage and to replace o-rings if necessary.

All oil / water separators have an integrated sinter filter which has to be replaced every 1,000 operating hours.

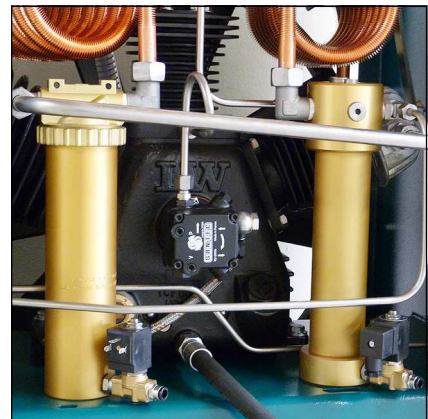

Oil / water separators 1st and 2nd stage



Condensate Catch Tank 10 Litre

AUTOMATIC CONDENSATION DRAIN

Oil / water separator 1st stage - maintenance



Note

Clean all parts thoroughly before assembly.

Change / clean oil / water separators 1st stage as follows:

- Loosen pipes and mounting screws.
- Remove oil / water separators.
- Open ring nut and remove separator top (Fig. 1).
- Open nut and remove separator top (Fig. 2).
- Change sinter filter (Fig. 3).
- Reassemble all parts and tighten nut.
- Change o-ring, previously grease new o-ring (Page 51, Fig. 4).
- Place separator top and tighten ring nut manually.
- Remove the base ring (Page 51, Fig. 5).
- Change o-rings, previously grease new o-rings (Page 51, Fig. 6).
- Remove the connection of the base ring and change the sinter filter (Page 51, Fig. 7).
- Reassemble the connection.
- Mount the base ring.
- Mount oil / water separator.
- Tighten pipes and mounting screws.

Oil / water separator maintenance is now completed.



Fig. 1 - Open ring nut and remove separator top



Fig. 2 - Loosen nut at the separator top



Fig. 3 - Change sinter filter

AUTOMATIC CONDENSATION DRAIN

Oil / water separator 1st stage - maintenance - continued from previous page



Fig. 4 - Change o-ring



Abb. 5 - Remove the base ring



Abb. 6 - Change o-rings



Abb. 7 - Change sinter filter

AUTOMATIC CONDENSATION DRAIN

Oil / water separators 2nd stage - maintenance



Note

Clean all parts thoroughly before assembly.

Maintenance / cleaning of oil / water separators 2nd stage as follows:

- Loosen pipes and mounting screws.
- Remove oil / water separators.
- Unscrew and remove filter top (Fig. 1).
- Open nut of separator top (Fig. 2).
- Change sinter filter (Fig. 3).
- Reassemble all parts and tighten nut.
- Pull the condensate stop valve out of the filter housing by using a threaded rod
- Change o-ring, previously grease new o-ring (Page 53, Fig. 4).
- Push the condensate stop valve into the filter housing by using a threaded rod.
- Change o-ring on the top of the filter housing, previously grease new o-ring (Page 53, Fig. 5).
- Place separator top and tighten manually.
- Remove the base ring (Page 53, Fig. 6).
- Change o-rings, previously grease new o-rings (Page 53, Fig. 7).
- Remove the connection of the base ring and change the sinter filter (Page 51, Fig. 8).
- Reassemble the connection.
- Mount the base ring.
- Mount oil / water separators.
- Tighten pipes and mounting screws.

The oil / water separator maintenance is now completed.



Fig. 1 - Unscrew and remove filter top

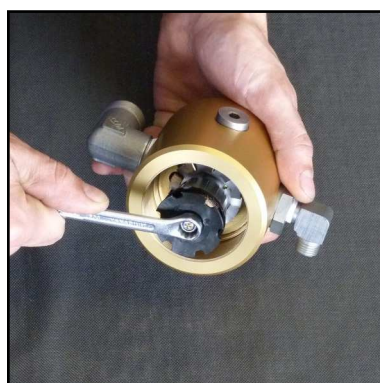

Fig. 2 - Loosen nut at the separator top



Fig. 3 - Change sinter filter

AUTOMATIC CONDENSATION DRAIN

Oil / water separators 2nd stage - maintenance - continued from previous page



Abb. 4 - Change o-ring



Abb. 5 - Change o-ring



Abb. 6 - Remove the base ring



Abb. 7 - Change o-rings



Abb. 8 - Change sinter filter

AUTOMATIC CONDENSATION DRAIN

Condensate stop valve - maintenance



Note

Clean all parts thoroughly before assembly.

Change/clean condensate stop valve as follows:

- Loosen pipes and mounting screws.
- Remove condensate stop valve housing.
- Remove allen bolts and pull off the cover by screwing two allen bolts into the threaded holes (Fig. 2).
- Pull the condensate stop valve out of the filter housing by using a threaded rod
- Change o-ring, previously grease new o-ring (Fig. 3).
- Push the condensate stop valve into the filter housing by using a threaded rod.
- Change o-ring of the cover, previously grease new o-ring (Fig. 4).
- Mount the cover, tighten the allen bolts crosswise.
- Remove the connection on the cover ring and change the sinter filter (Fig. 5).
- Reassemble the connection
- Mount condensate valve housing.
- Tighten mounting screws and pipes

The oil / water separator maintenance is now completed.

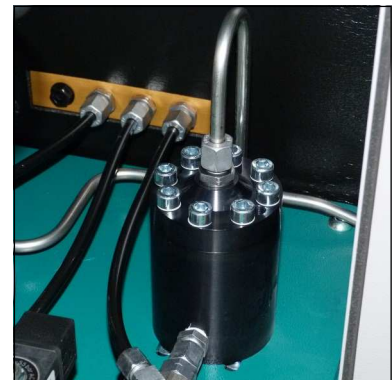

Fig. 1 - Condensate stop valve housing



Fig. 2 - Remove the cover



Abb. 3 - O-Ring wechseln
(Kondensat-Stopp-Ventil)



Abb. 4 - O-Ring wechseln (Deckel
Kondensat-Stopp-Ventil)



Abb. 5 - Sinterfilter wechseln

AUTOMATIC CONDENSATION DRAIN

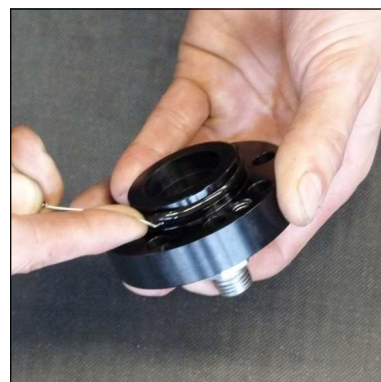
Pneumatic condensate valve - maintenance



Note

Clean all parts thoroughly before assembly.

Pneumatic condensate valve change as follows:

- Loosen pipe connections and mounting screws.
- Remove pneumatic condensate valve.
- Loosen connection (Fig. 2).
- Change sinter filter (Fig. 3).
- Tighten horizontal screw.
- Mount pneumatic condensate valve.
- Tighten pipe connections and mounting screws.

Pneumatic condensate valve maintenance is now completed.



Pneumatic Condensate Valve

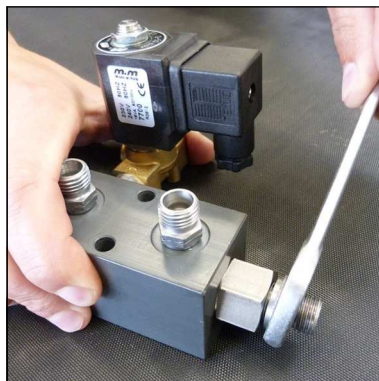

Fig. 2 - Loosen connection

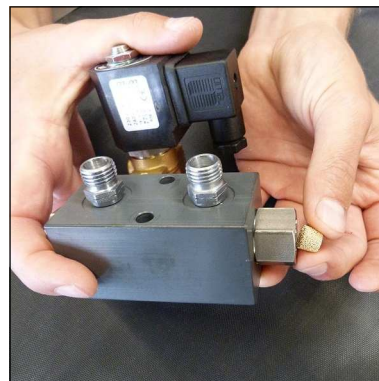

Fig. 3 - Change sinter filter

AUTOMATIC CONDENSATION DRAIN

Pre-Filter 0.8 ltr

In particle filter particles are filtered out up to a size of $10\ \mu\text{m}$. The pre-filter are separating water before final filter housing.

Maintenance intervals

The life of the 0.8 ltr filter cartridge is substantially depend on the operating temperature, from the state of wear of the compressor, of the filter size and the operating pressure.

It needs to be cleaned annually and serviced when 1000h are reached. We recommend to monitor the state of the filter.



Filterhousing 1.7l (right), and filter unit 0,8l with safety valve (left)

D

AUTOMATIC CONDENSATION DRAIN

0.8ltr filter element change

Filter element change as follows:

- Start the compressor and run up to a pressure of 100 bar.
- Stop the compressor.
- Open vent tap to release pressure from 1.7l filter housing.
- Loosen pipe connections and mounting screws (Fig. 1 a. 2)
- Remove complete pre-filter housing.
- Open pre-filter cover (Fig. 3).
- Change the filter element (stuck in filter cover) (Fig. 4).
- Change o-ring, previously grease new o-ring .
- Grease thread of filter cover, o-ring and back-up ring.
- Reassemble pre-filter cover and filter housing. Note the correct position of th filter back-up!
- After you have screwed it completely, loosen the pre-filter cover about 90 °. This avoids a terminals of the pre-filter cover due to a hard shaking while operation.

The filter element change is now completed.



Note

Ensure that the old filter element is disposed correctly at an approved waste point.



Fig. 1 - Loosen pipe connections and mounting screws



Fig. 2 - Loosen pipe connections and mounting screws

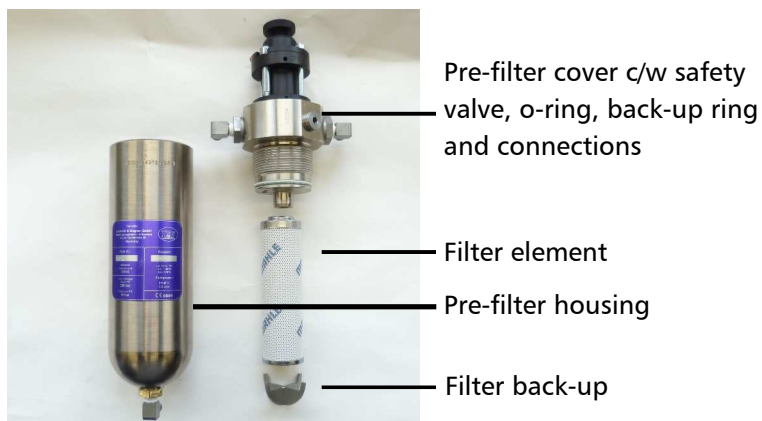

Fig. 4 - 0.8ltr pre-filter parts



Fig. 3 - Open pre-filter cover

AUTOMATIC CONDENSATION DRAIN

0,8l Pre-filter housing - maintenance



Note

Clean all parts thoroughly before assembly.

Pre-filter housing maintenance as follows:

Dismount pre-filter housing

- Loosen pipe connections and nuts (siehe S.59, Abb. 1 u.2).
- Remove pre-filter housing.

Pre-filter housing maintenance

- Open pre-filter Cover (siehe S.59, Abb. 3).
- Change o-ring and back-up ring, previously grease both (Abb. 1)
- Screw filter base tight in



Fig. 1 - Change o-ring and back-up ring

Install pre-filter housing

- Connect pipe connections and tighten.
- Adjust holding clamp and tighten nuts

The pre-filter housing maintenance is now completed.

D

AUTOMATIC CONDENSATION DRAIN

Oil / water separators final stage - maintenance



Note

Clean all parts thoroughly before assembly.

Change/clean oil / water separators final stage as follows:

- Loosen pipe connections and mounting screws.
- Remove oil / water separators.
- Open ring nut and remove separator top (Fig. 1).
- Loosen nut at the separator top.
- Change sinter filter (Fig. 2).
- Reassemble all parts and tighten nut.
- Change o-ring, previously grease new o-ring (Fig. 3).
- Place separator top and tighten ring nut manually.
- Replace silencer.
- Mount oil / water separators.
- Tighten pipe connections and mounting screws.

The oil / water separator maintenance is now completed.

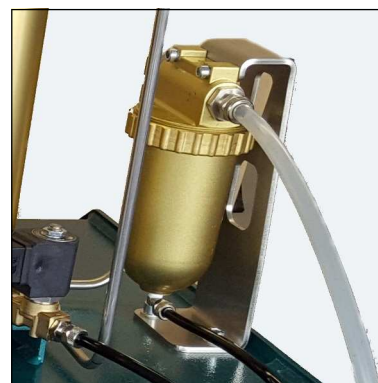

Oil / water separators final stage



Fig. 1 - Loosen ring nut

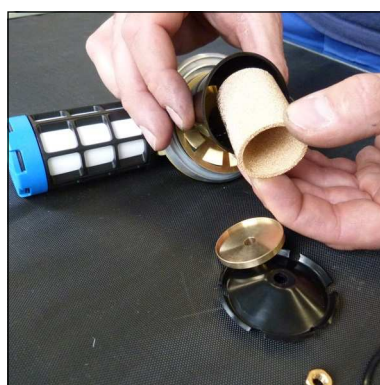

Fig. 2 - Change sinter filter

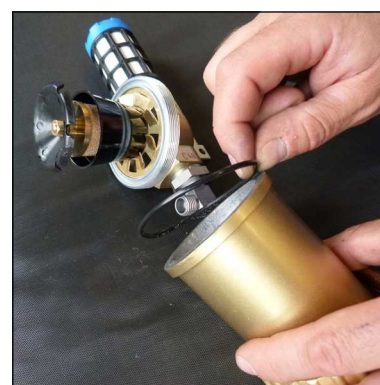

Fig. 3 - Change o-ring

AUTOMATIC CONDENSATION DRAIN

Leak test



Note

Do not fill any tank during test phase!

Leak test as follows:

- Disconnect the compressor from the electrical power supply and protect against unexpected restart.
- Remove the cover of the switch box.
- Switch on the leak test switch (solenoid valves will be deactivated!).
- Mount the cover of the switch box.
- Connect the compressor to the electrical power supply.
- Close filling valves.
- Start the compressor.
- Switch off the compressor at a pressure of approx. 150 bar.
- Verify the compressor for release noises. (A slight hiss of the air inlet filter nozzle can be ignored). If release noises occur, localise blow off position(s).
- Switch off the compressor.
- Disconnect the compressor from the electrical power supply and protect against unexpected restart.
- Remove the cover of the switch box.
- Switch off the leak test switch (solenoids will be activated!).
- Mount the cover of the switch box.
- Connect the compressor to the electrical power supply (compressor vented).

The leak test is now completed.

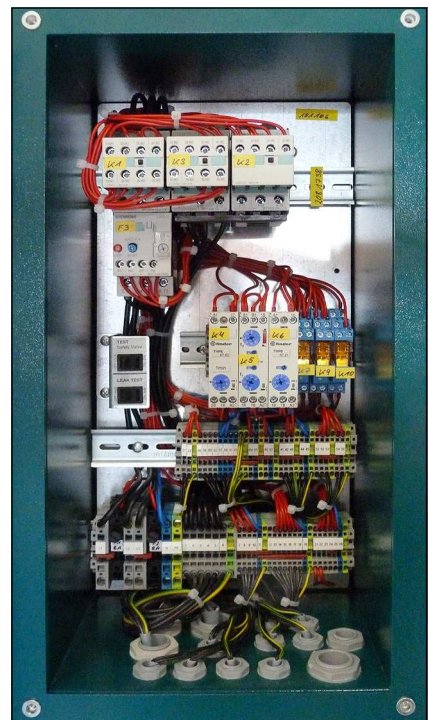

Switch box

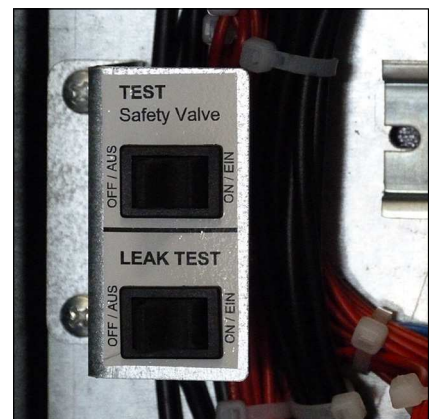

Leak test switch (lower)

AUTOMATIC CONDENSATION DRAIN

Switch box with condensate drain test switch

| Best.-Nr. / Order No. | Benennung | Description |
|-----------------------|------------------------------|---------------------------|
| 002089 | Betriebsstundenzähler | Hour counter |
| 002502 | Kondensat Test Schalter | Drain test switch |
| 002942 | START/STOP Schalter mit LED | Start/Stop switch c/w LED |
| 003121 | NOT-AUS Schalter | Emergency switch |
| 004704 | Warnlampe | Warning Lamp |
| 005670 | Einlegeschild Kondensat Test | Label Drain Test |
| 006859 | Schildträger | Label holder |
| 006925 | Einlegeschild Motorschutz | Label Motor protect |

D





AUTOMATIC CONDENSATION DRAIN

Öl- / Wasserabscheider 1. Stufe / Oil- / Water Separator 1st Stage

| Best.-Nr. / Order No. | Benennung | Description |
|-----------------------|---|--|
| 000175 | Deckel, Wasserabscheider | Cover Water Separator |
| 000183 | Wasserabweiser | Filter Protector |
| 000184 | Sinterfilter Wasserabscheider | Sintered Filter, Oil Filter |
| 000185 | Halteteller | Plate |
| 000186 | Drallscheibe | Twist Disk |
| 000187 | Stiftschraube | Threaded Stud |
| 000820 | Verschraubung WE 15L RX | Elbow Connection |
| 000822 | Mutter 15L | Nut 15L |
| 000823 | Schneidring PSR 15 LX | Olive Seal 15mm |
| 000861 | Schneidring PSR 18 LX | Olive Seal 18mm |
| 000862 | Mutter M18L | Nut 18L |
| 000863 | Verschraubung WE 18L | Elbow Connection |
| 001133 | Sechskant Schraube M12x30mm DIN933 8.8 ZN | Hexagon Screw M12x30mm DIN933 8.8 ZN |
| 001191 | U-Scheibe A12 DIN125 ZN | Washer A12 DIN125 ZN |
| 001192 | Federring A12 DIN 127 ZN | Spring Washer A12 DIN 127 ZN |
| 001272 | O-Ring 47x3 NBR70 | O-Ring 47x3 NBR70 |
| 001294 | O-Ring 68x3 NBR90 | O-Ring 68x3 |
| 001431 | Befestigungsring Wasserabscheider LW 450 | Lock Ring Water Separator |
| 002563 | Wasserabscheider Oberteil | Water Separator Top |
| 002914 | Sinterfilter für Wasserabscheider- sockel, M12x1,5mm | Sintered filt. water sep. base, M12x1,5mm |
| 003347 | Unterer Ring, Wasserabscheider | Base Ring, water separator |
| 003348 | Filterverschraubung für Wasserabscheider | Connec. for sintered filter |
| 006421 | Wasserabscheider-Behälter | Container Water Separ. |
| 006845 | Stopfmutter, Edelstahl, M6 DIN985 | Lock Nut, s/s, M6 DIN985 |

D

AUTOMATIC CONDENSATION DRAIN

Öl- / Wasserabscheider 1. Stufe / Oil- / Water Separator 1st Stage

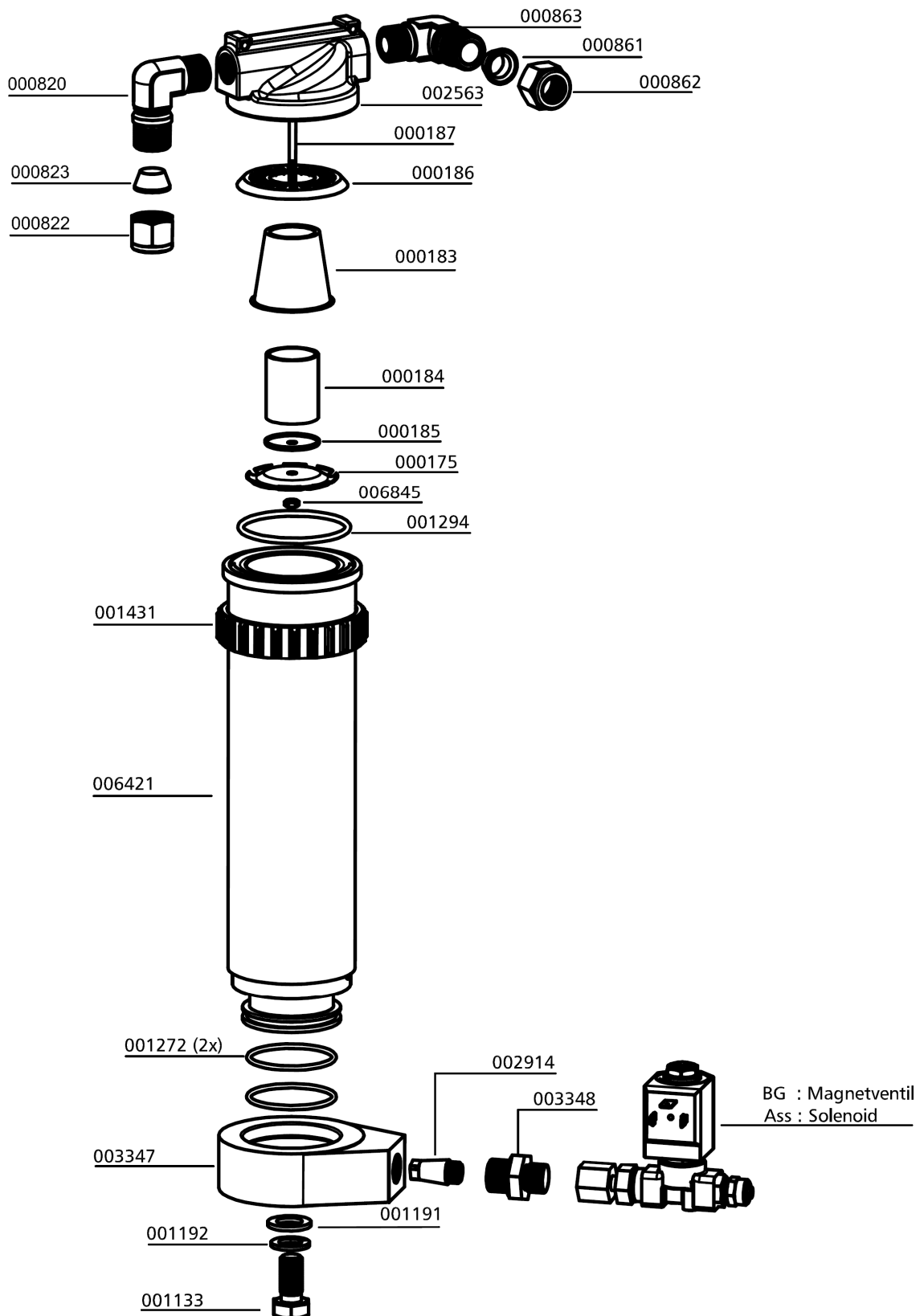

D



AUTOMATIC CONDENSATION DRAIN

Öl- / Wasserabscheider 2. Stufe / Oil- / Water Separator 2nd Stage

| Best.-Nr. / Order No. | Benennung | Description |
|-----------------------|---|--|
| 000172 | Halteteller Wasserabscheider | Plastic Air Deflector |
| 000173 | Sinterfilter Wasserabscheider | Sintered Filter |
| 000174 | Drallscheibe, Wasserabscheider | Twist Disk |
| 000176 | Stiftschraube, Wasserabscheider | Treaded Stud |
| 000177 | Wasserabweiser, Wasserabscheider | Water Deflector, Plastic |
| 000379 | Wasserabscheider - Oberteil | Top ap Water Separator |
| 000564 | Wasserabscheider – Behälter 2.Stufe LW450 | Container Water Separator |
| 000761 | Verschraubung WE08LRCTX | Elbow Connection WE08LRCTX |
| 000765 | Schneidring PSR 08 LX | Olive Seal PSR 08 LX |
| 000766 | Mutter L08 | Nut L08 |
| 000837 | Verschlussstopfen, VSTI R1/4"ED CFX | Plug |
| 000839 | Verschlussstopfen, VSTI R3/8"ED CFX | Plug |
| 000863 | Verschraubung | Elbow Connection |
| 000924 | Reduzierung 1/4"x1/8" | Reducer 1/4"x1/8" |
| 001133 | Sechskantschraube M12x30mm DIN933 8.8 ZN | Hexagon Screw M12x30mm DIN933 8.8 ZN |
| 001191 | U-Scheibe A12 DIN125 ZN | Washer A12 DIN125 ZN |
| 001192 | Federring A12 DIN 127 ZN | Spring Washer A12 DIN 127 ZN |
| 001272 | O-Ring Wasserabscheider 47x3 NBR70 | O-Ring 47x3 |
| 002914 | Sinterfilter für Wasserabscheider- sockel, M12x1,5mm | Sintered filt. water sep. base, M12x1,5mm |
| 003347 | Unterer Ring, Wasserabscheider | Base Ring, water separator |
| 006845 | Stopfmutter, Edelstahl, M6 DIN985 | Lock Nut, s/s, M6 DIN985 |
| 008827 | Kondensat-Stopp-Ventil Einsatz | Condensate-Stop-Valve Assembly |
| 009693 | Filterverschraubung für Wasserab- scheider | Connec. for sintered filter |

AUTOMATIC CONDENSATION DRAIN

Öl- / Wasserabscheider 2. Stufe / Oil- / Water Separator 2nd Stage

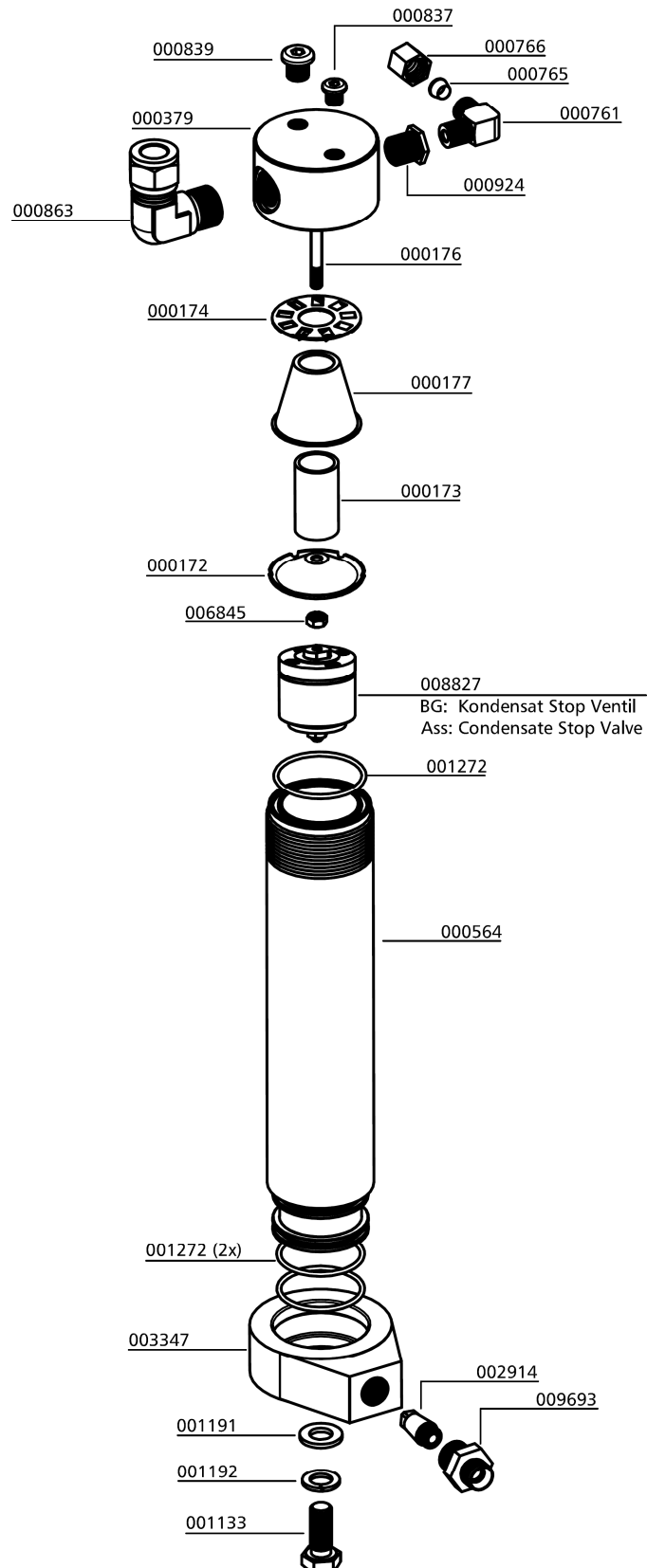

D



AUTOMATIC CONDENSATION DRAIN

Filter 0,8l / Filter 0.8ltr

| Best.-Nr. / Order No. | Benennung | Description |
|-----------------------|---|---------------------------------------|
| 000761 | Verschraubung WE08LRCFX | Elbow Connection WE08LRCFX |
| 000838 | Verschlussstopfen VSTIR1/4EDCF | Plug VSTIR1/4EDCF |
| 000921 | Reduzierung RI1/2X1/4CFX | Reducer RI1/2X1/4CFX |
| 001158 | Mutter M8 DIN934 ZN | Nut M8 DIN934 ZN |
| 001181 | U-Scheibe A8 DIN125 ZN | Washer A8 DIN125 ZN |
| 003980 | Partikelfilterpatrone | Particle filter cartridge |
| 003994 | Filterbehälter 350 bar, 0,8 l, komplett | Filter case 350 bar, 0.8ltr, complete |
| 003997 | Filterstütze Partikelfilter 0,8 l | Filter support 0,8 ltr |
| 004221 | O-Ring, 54,2 x 3,0 FKM80 | O-Ring, 54,2 x 3,0 FKM80 |
| 004222 | Stützring 55,4x60x1,4 | Back-up Ring 55,4x60x1,4 |
| 006363 | Haltebügel Filtergehäuse 0,8 l | U-Clamp Filterhousing 0.8 ltr |
| 006364 | Halteschalen Filtergehäuse 0,8 l | Bracket Filter Housing 0.8 ltr |

D

AUTOMATIC CONDENSATION DRAIN

Filter 0,8l / Filter 0.8ltr

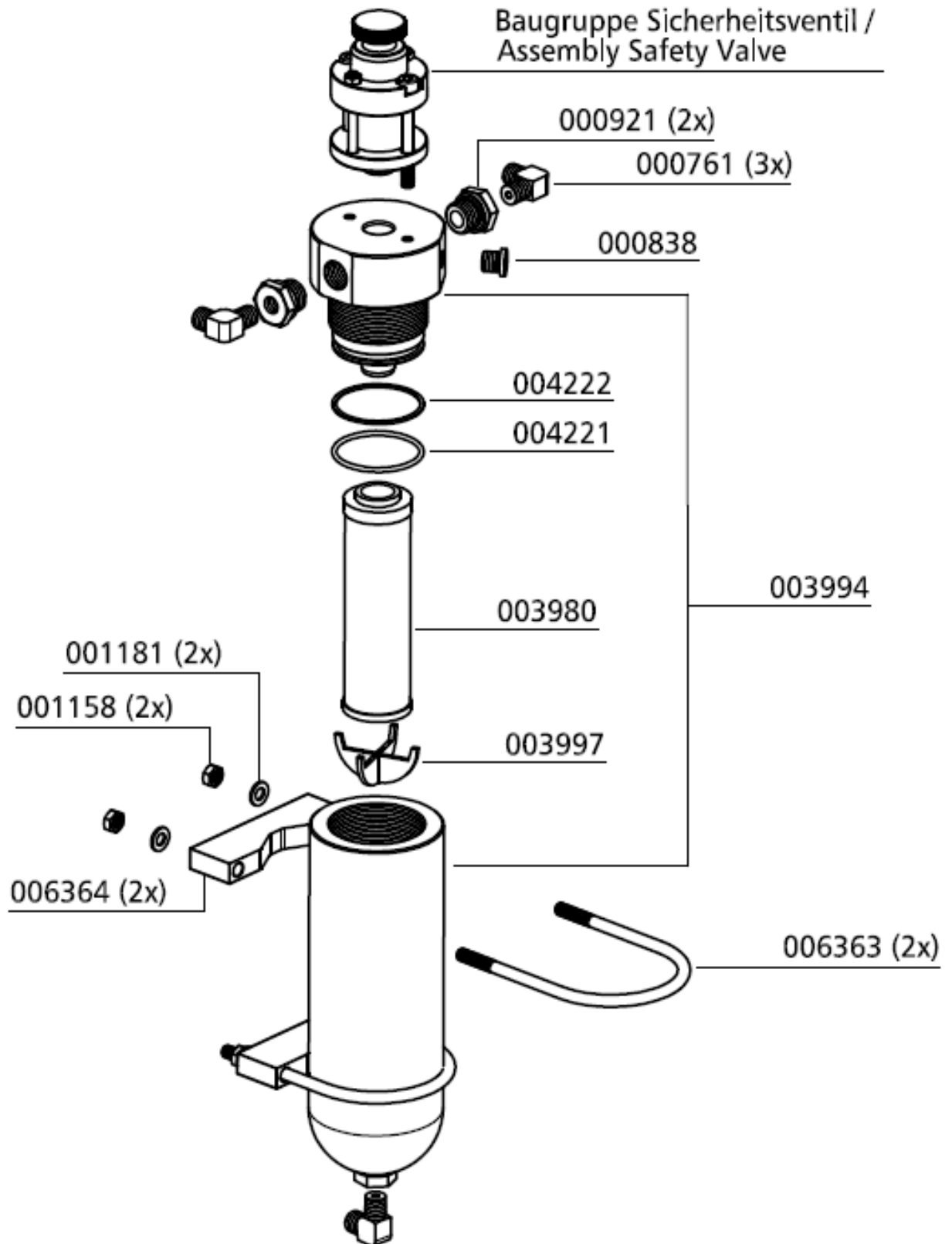

D



AUTOMATIC CONDENSATION DRAIN

Öl- / Wasserabscheider Endstufe / Oil- / Water Separator Final Stage

| Best.-Nr. / Order No. | Benennung | Description |
|-----------------------|--|---|
| 000175 | Deckel, Wasserabscheider | Cap |
| 000178 | Schalldämpfer G1/2" | Silencer G1/2" |
| 000183 | Wasserabweiser | Filter Protecor |
| 000184 | Sinterfilter Wasserabscheider | Siltered Filter, Oil Filter |
| 000185 | Halteteller | Plate |
| 000186 | Drallscheibe | Twist Disk |
| 000498 | Unterlegscheibe | Washer A6 |
| 000761 | Verschraubung WE 08 PLR CFX | Connection |
| 000921 | Reduzierung 1/2"-1/4" | Reducer 1/2"-1/4" |
| 001027 | Zylinderschraube M6x30 | Allen Bolt M6x30 |
| 001039 | Zylinderschraube M8x16mm DIN912 8.8 ZN | Allen Bolt M8x16mm DIN912 8.8 ZN |
| 001156 | Stopfmutter M6 DIN985 ZN | Lock Nut M6 |
| 001181 | U-Scheibe A8 DIN125 ZN | Washer A8 DIN125 ZN |
| 001294 | O-Ring 68x3 NBR90 | O-Ring 68x3 |
| 001431 | Befestigungsring Wasserabscheider LW 450 | Lock Ring Water Separator |
| 002466 | Kondensatbehälter für Abscheider | Condensate bowl |
| 002563 | Wasserabscheider Oberteil PN 15 bar | Water Separator, upper comp. PN15 bar |
| 005856 | Winkeleinschraubverschraubung, G1/8" - 8 mm, inkl. Mutter | Elbow Hose Connection, G1/8" - 8 mm, c/w nut |
| 007068 | Halter Endabscheider a. Grundkon- sole, Edelstahl, s/s | Bracket Final Separator, s/s |

D

AUTOMATIC CONDENSATION DRAIN

Öl- / Wasserabscheider Endstufe / Oil- / Water Separator Final Stage

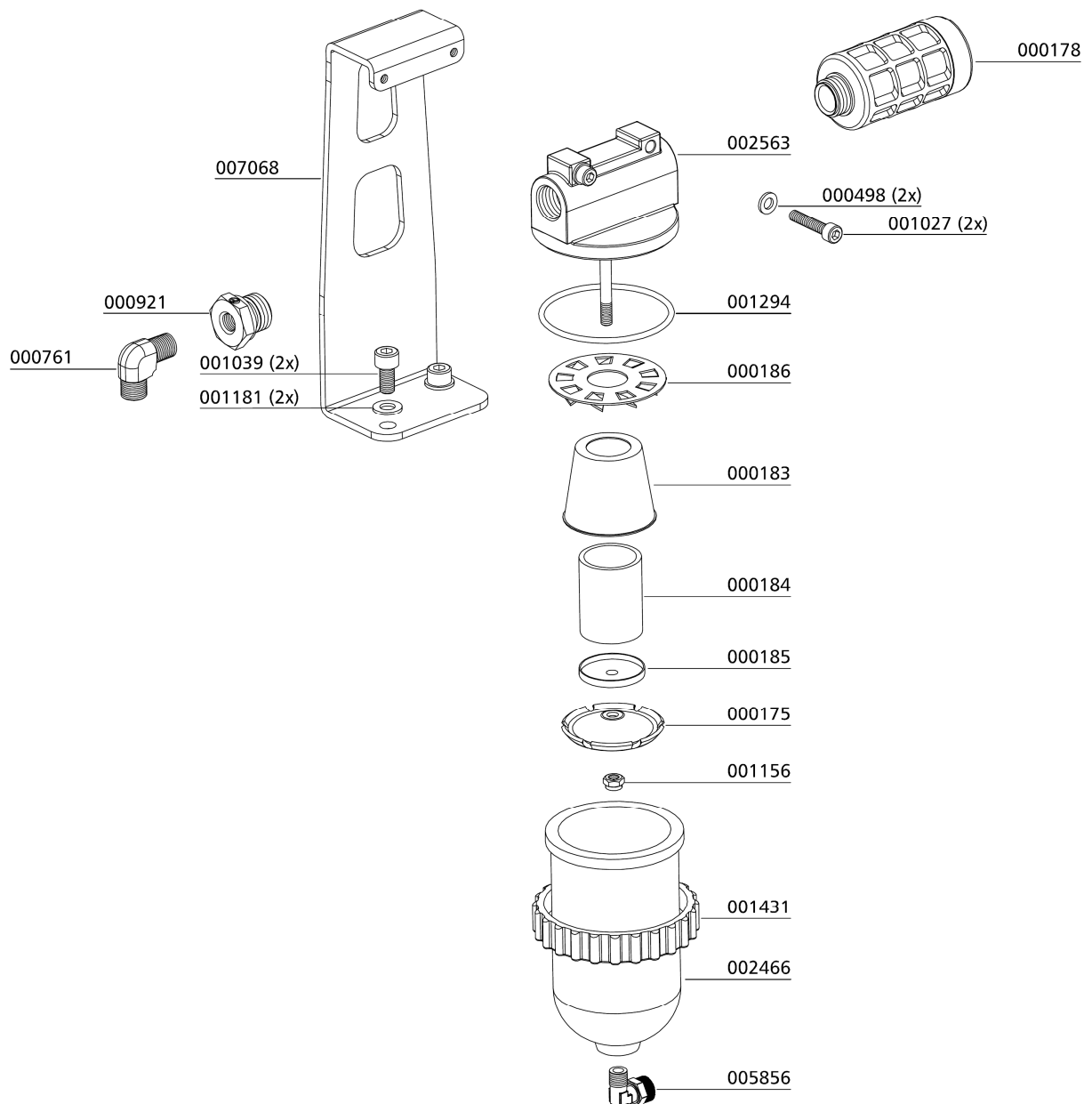

D



AUTOMATIC CONDENSATION DRAIN

Baugruppe: Kondensat-Stopp-Ventil-Gehäuse / Assembly: Housing Condensate-Stop-Valve

| Best.-Nr. / Order No. | Benennung | Description |
|-----------------------|---|--|
| 000739 | Verschraubung GE08L/1/4KEGCFX | Connection GE08L/1/4KEGCFX |
| 000741 | Verschraubung, GE08LR3/8CFX | Connection, GE08LR3/8CFX |
| 000765 | Schneidring PSR 08 LX | Olive Seal PSR 08 LX |
| 000766 | Mutter M08LCFX | Nut M08LCFX |
| 001055 | Zylinderschraube, M8x55mm DIN912 8.8 ZN | Allen Screw, M8x55mm DIN912 8.8 ZN |
| 001184 | Schnorr-Scheibe S8 N0110 ZN | Clamp Washer S8 S8 N0110 ZN |
| 002914 | Sinterfilter für Wasserabscheidersockel, M12x1,5mm AG | Sintered filt. water sep. Base, M12x1,5mm AG |
| 006368 | Behälter Kondensat-Stopp-Ventil | Container Condensate-Stop-Valve |
| 006369 | Behälterdeckel Kondensat-Stopp-Ventil | Cover Condensate-Stop-Valve |
| 006382 | O-Ring 38x3,5 NBR90 | O-Ring 38x3,5 NBR90 |
| 008827 | Kondensat-Stopp-Ventil Einsatz | Condensate-Stop-Valve Assembly |
| 008828 | Kondensat-Stopp-Ventil kompl., inkl. Ventileinsatz 008827 | Condensate-Stop-Valve, compl., incl. valve assembly 008827 |

D

AUTOMATIC CONDENSATION DRAIN

Baugruppe: Kondensat-Stopp-Ventil-Gehäuse / Assembly: Housing Condensate-Stop-Valve

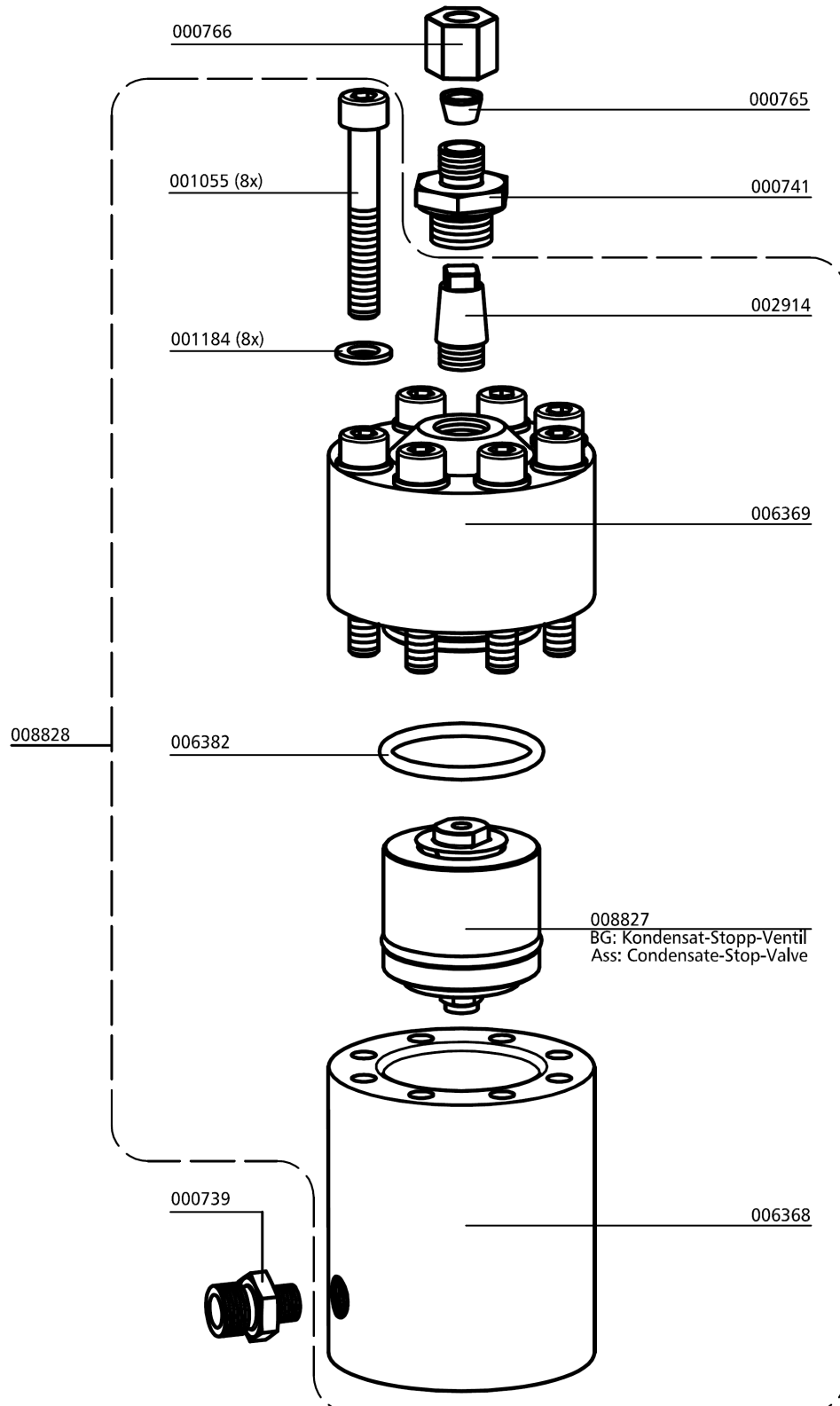

D



AUTOMATIC CONDENSATION DRAIN

Baugruppe: Kondensat-Stopp-Ventil / Assembly: Condensate-Stop-Valve

| Best.-Nr. / Order No. | Benennung | Description |
|-----------------------|------------------------------------|------------------------------------|
| 000498 | U-Scheibe DIN 125 A6 | Washer DIN 125 A6 |
| 001156 | Stopfmutter M6 DIN985 ZN | Lock Nut M6 DIN985 ZN |
| 001264 | O-Ring, 38 x 3 NBR70 | O-Ring, 38 x 3 NBR70 |
| 006370 | Gehäuse Kondensat-Stopp-Ventil | Housing-Condensate-Stop-Valve |
| 006372 | Ventilkegel Kondensat-Stopp-Ventil | Valve Condensate Stop Valve |
| 006373 | Stauscheibe Kondensat-Stopp-Ventil | Baffle Plate Condensate Stop Valve |
| 006380 | Druckfeder | Compression Spring |
| 008827 | Kondensat-Stopp-Ventil Einsatz | Condensate-Stop-Valve Assembly |

D

AUTOMATIC CONDENSATION DRAIN

Baugruppe: Kondensat-Stopp-Ventil / Assembly: Condensate-Stop-Valve

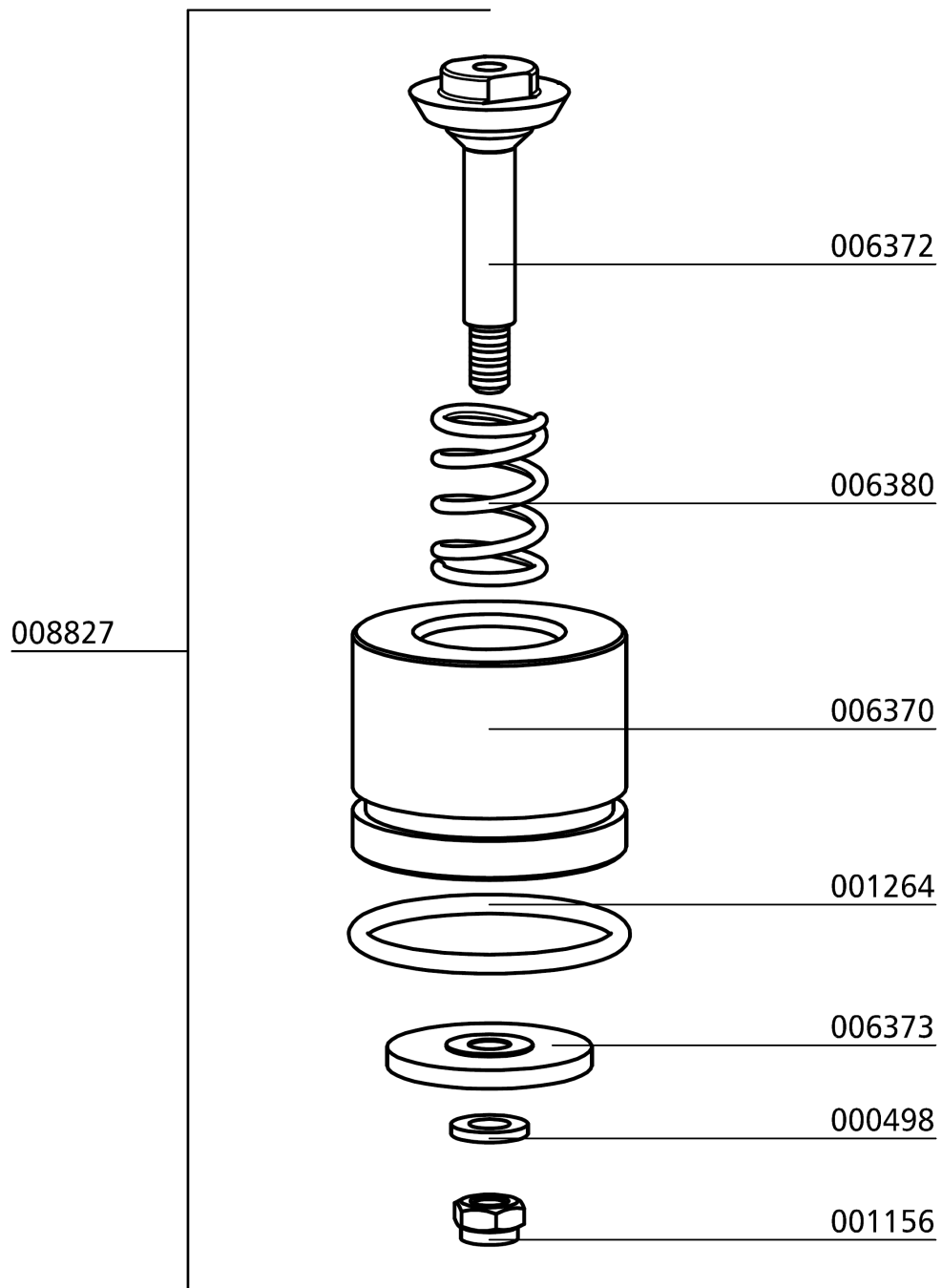

D



AUTOMATIC CONDENSATION DRAIN

Pneum. Kondensat-Ablassventil / Pneumatic Condensate Valve

| Best.-Nr. / Order No. | Benennung | Description |
|-----------------------|---|----------------------------------|
| 000188 | Sinterfilter | Sintered Filter |
| 000191 | Steuerkolben, pneum. Kondensatventil | Piston |
| 000194 | Reparatursatz pneum. Kondensatventil | Repair Kit Condensate Valve |
| 000196 | Düsenschraube, pneum. Kondensatventil | Inlet Jet Screw |
| 000197 | Stopfen, pneum. Kondensatventil | Plug |
| 000198 | Gehäuse, pneum. Kondensatventil | Body PCV |
| 000199 | Pneum. Kondensatventil (Kondensatablassventil) | Pneumatic Condensate Valve |
| 000498 | U-Scheibe DIN 125 A6 | Washer DIN 125 A6 |
| 000737 | Verschraubung GE08LR1/8CFX | Connection GE08LR1/8CFX |
| 000738 | Verschraubung GE08LR1/8CFX | Connection GE08LR1/8CFX |
| 000765 | Schneidring PSR 08 LX | Olive Seal PSR 08 LX |
| 000766 | Mutter M08LCFX | Union Nut M08LCFX |
| 001011 | Zylinderschraube M6x60mm DIN912 8.8 ZN | Allen Bolt M6x60mm DIN912 8.8 ZN |

D

AUTOMATIC CONDENSATION DRAIN

Pneum. Kondensat-Ablassventil / Pneumatic Condensate Valve

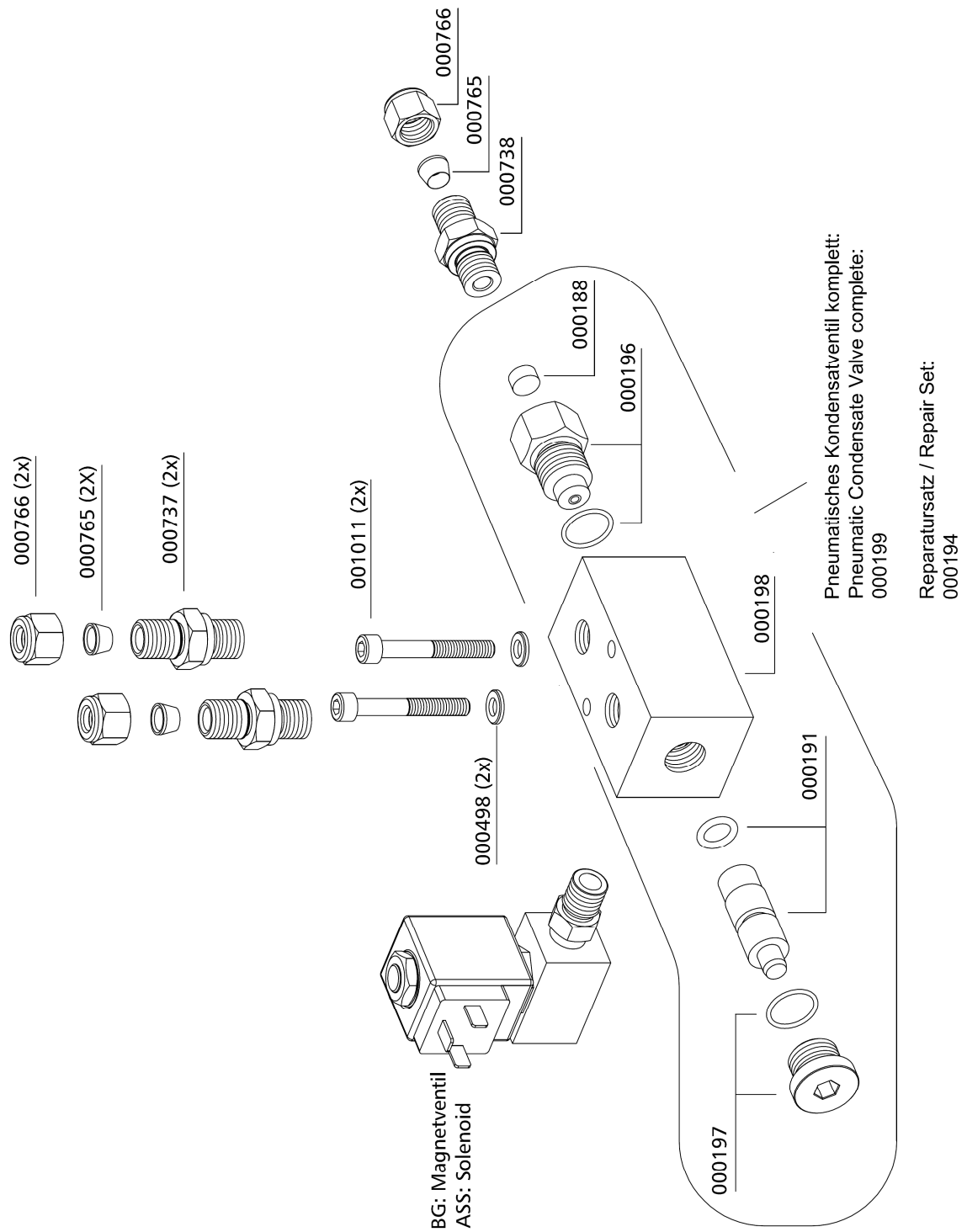

D

AUTOMATIC CONDENSATION DRAIN

Baugruppe: Magnetventil / Assembly: Solenoid

| Best.-Nr. / Order No. | Benennung | Description |
|-----------------------|---|---|
| 000892 | Doppelnippel 4F3MK4S G1/8"-1/4" | Double Nipple 4F3MK4S G1/8"-1/4" |
| 001546 | Aludichtring für Magnetventile G1/4", 18 x 13,2 x 2,5mm | Alloy Seal Ring for solenoid G1/4", 18 x 13,2 x 2,5mm |
| 005857 | Gerade Einschraubverschraubung, G1/4" - 8 mm | Straight Hose Connection, G1/4" - 8 mm |
| 006113 | Magnetventil 0-55bar, komplett mit Spule | Solenoid 0-55bar, c/w coil |

D

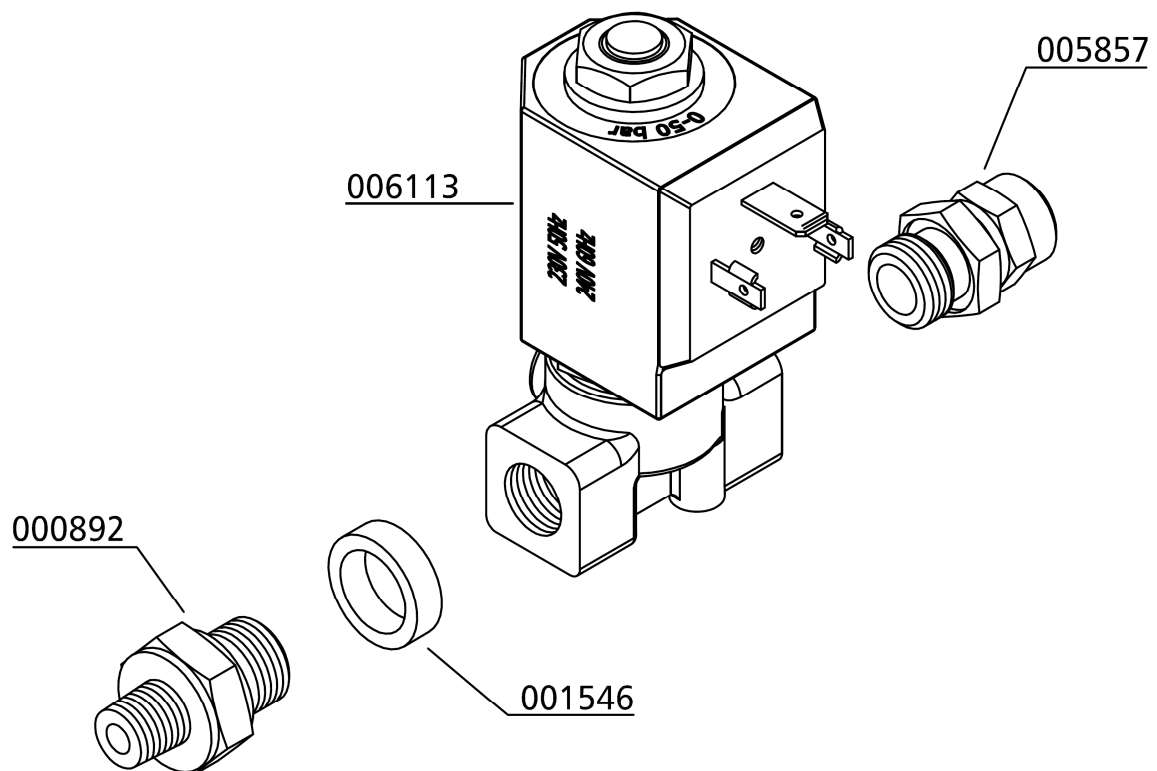



AUTOMATIC CONDENSATION DRAIN

Magnetventil mit Rückschlagventil / Solenoid Valve with non-return valve

| Best.-Nr. / Order No. | Benennung | Description |
|-----------------------|---|---|
| 000741 | Verschraubung, GE08LR3/8CFX | Connection, GE08LR3/8CFX |
| 000749 | Verschraubung mit fester Mutter, EVGE 08 PLR-ED | Connection with fixed nut, EVGE 08 PLR-ED |
| 000757 | T-Verschraubung mit fester Mutter, EVL08LOMDCF | T-Connection with fixed nut, EVL08LOMDCF |
| 000765 | Schneidring, PSR 08 LX | Olive Seal, PSR 08 LX |
| 000766 | Mutter, M08LCFX | Nut, M08LCFX |
| 001472 | Magnetventil, Edelstahl, 350bar 230V/50Hz | Solenoid, s/s, 350 bar 230V/50Hz |
| 001546 | Aludichtring für Magnetventile G1/4" | Alloy Seal Ring for G1/4" male |
| 003159 | Sinterfilter G1/4" mit Schlitz | Sintered filter G1/4" male with slot |
| 003707 | Rückschlagventil, Stahl, 2 x G3/8" | Non-Return Valve, steel, 2 x G3/8" |

D

AUTOMATIC CONDENSATION DRAIN

Magnetventil mit Rückschlagventil / Solenoid Valve with non-return valve

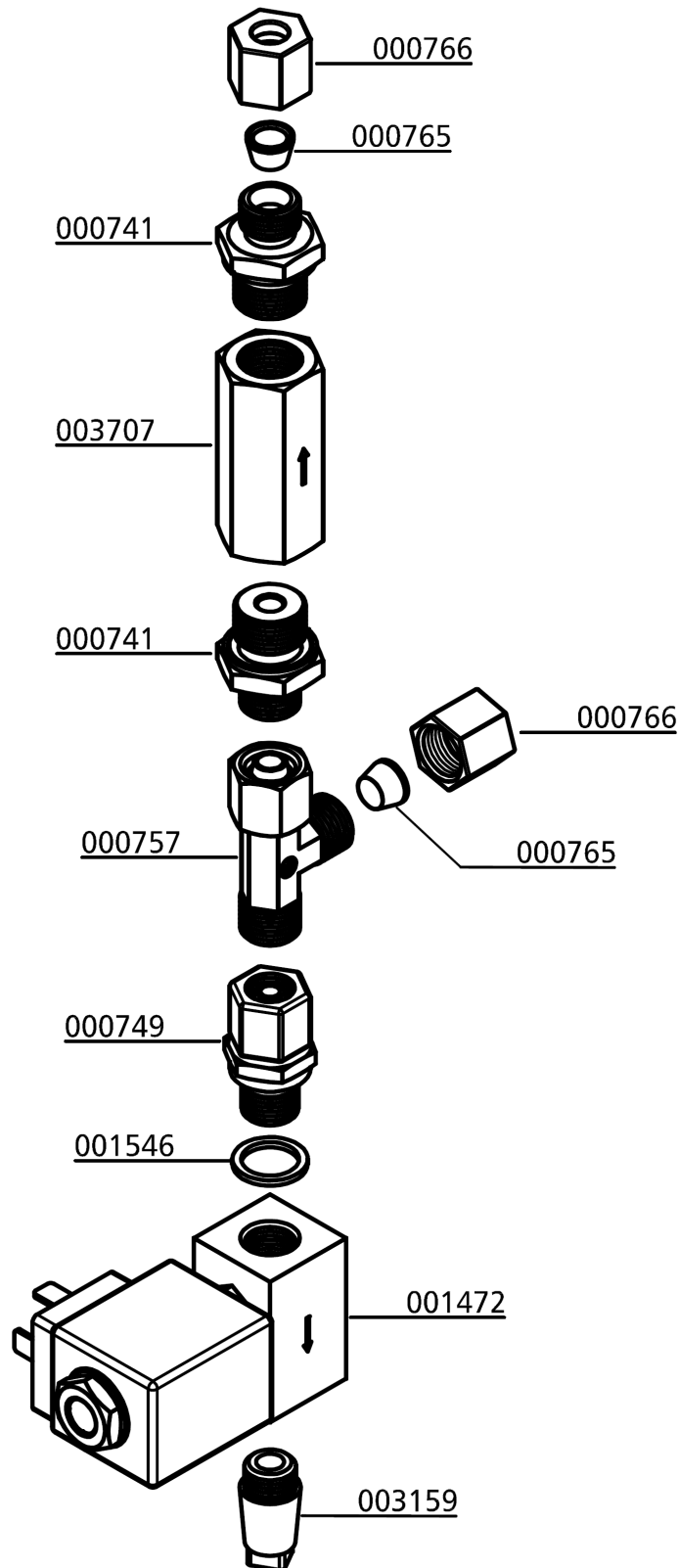

D



AUTOMATIC CONDENSATION DRAIN

Baugruppe: Kondensat-Sammelbehälter / Assembly: Housing Condensate-Catch-Tank

| Best.-Nr. / Order No. | Benennung | Description |
|-----------------------|---|---|
| 000739 | Verschraubung GE08L/1/4KEGCFX | Connection GE08L/1/4KEGCFX |
| 000779 | Verschlussstopfen 1/4" HHP-S | Plug 1/4" HHP-S |
| 001179 | U-Scheibe A6 M0030 ZN | Washer A6 M0030 ZN |
| 002152 | O-Ring 80x2,5 NBR70 | O-Ring 80x2,5 NBR70 |
| 005842 | Linsenflanschschraube mit Innensechskant M6x16 mm, DIN 7380F, | Lens Head Screw M6x16 mm, DIN 7380F, 10.9 |
| 006106 | Linsenflanschschraube mit Innensechskant M6x10 mm - DIN7380, Zn | Socket Button Head M6x10 mm - DIN7380, Zn |
| 006356 | Kondensatbehälter 10 Liter | Condensate Catch Tank 10 Litre |
| 006379 | Zugfeder Kondensatfilterpatrone | Spring Condensate Filter Cartr |
| 006459 | Adapter Kondensatbehälter | Adapter Condensate Catch Tank |
| 006460 | Federspannblech Kondensatbehälter | Spring Clamping Plate CCT |
| 006461 | Halteblech Kondensatbehälter | Bracket Condensate Catch Tank |
| 006462 | Filter Kondensatbehälter | Filter Condensate Catch Tank |
| 008357 | Verschlusskappe für 006356 | Cap for Condensate Catch Tank 006356 |
| 009995 | Kondensatschlauch, Ø8x1,5, L: 565mm | Condensate Hose Ø8x565mm |
| 009996 | Kondensatschlauch, Ø8x1,5, L: 580mm | Condensate Hose Ø8x580mm |
| 009997 | Kondensatschlauch, Ø8x1,5, L: 612mm | Condensate Hose Ø8x612mm |

D

AUTOMATIC CONDENSATION DRAIN

Baugruppe: Kondensat-Sammelbehälter / Assembly: Housing Condensate-Catch-Tank

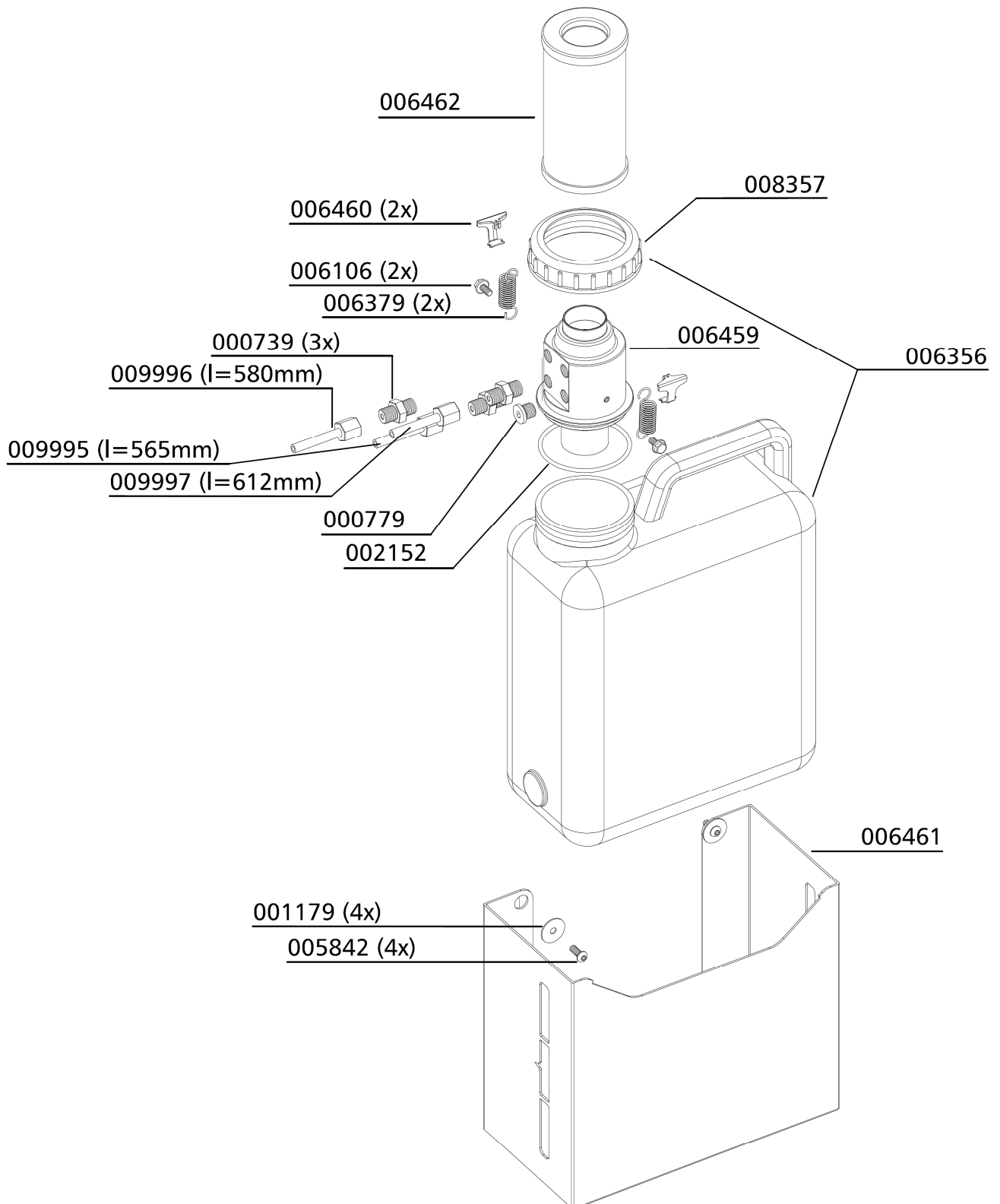

D



AUTO START FUNCTION

D

AUTO START FUNCTION

Auto Start Function

The auto start function allows operating the compressor optionally in automatic or semi-automatic mode by turning the selector switch.

Semi-automatic operation:

Start the compressor by pushing the Start button. The compressor automatically shuts off when final pressure is reached. To restart the compressor, push the Start button again. The unit can be shut down at any time during operation by pushing the Stop button.



Selector switch auto start function

Automatic operation:

Start the compressor only once by pushing the Start button. The Start button lights up and the unit automatically shuts off when final pressure is reached. If outlet pressure decreases below the selected minimum pressure, the unit automatically restarts.



Note

The compressor can not be manually started during automatic operation.

To enable a manual start, shut off automatic operation by pushing the Stop button (Start button lamp goes out). Now turn selector switch to semi-automatic mode and start the compressor with the Start button.

Adjust re-start pressure (minimum filling pressure)

The pressure switch for start pressure is located after the pressure maintaining valve. The pressure can be adjusted with the upper adjusting screw.

Increasing re-start pressure: turn adjusting screw clockwise

Reducing re-start pressure: turn adjusting screw anti-clockwise

Adjust pressure switch in steps of a quarter turn. Check settings after every adjustment step.

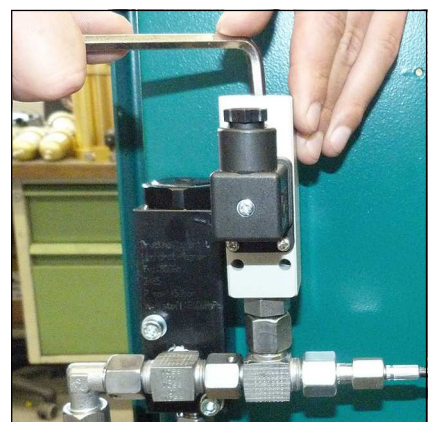

Adjust re-start pressure

AUTO START FUNCTION

Filling procedure semi-automatic operation



Caution! Only fill cylinders which:

- are marked with the test mark and the test stamp of the expert.
- have been hydro static tested (check last test date).
- are rated for the final pressure.
- are free from humidity.



Note

The unit shuts down when final pressure is reached. Thus, the unit always has to be restarted manually.

1. Turn selector switch to semi-automatic mode.
2. Close all filling valves.
3. Connect closed compressed air cylinders.
4. Open filling valves.
5. Start compressor by pushing the ON button.
6. When filling pressure gauge increases, open filling valves slowly.
7. Fill compressed air cylinders to the desired pressure, subsequently close filling valves slowly.
8. Close and vent all filling valves.
9. Disconnect all compressed air cylinders from filling valves.

AUTO START FUNCTION

Filling procedure automatic operation

**Caution! Only fill cylinders which:**

- are marked with the test mark and the test stamp of the expert.
- have been hydro static tested (check last test date).
- are rated for the final pressure.
- are free from humidity.

**Note**

The unit shuts down when final pressure is reached. Thus, the unit always has to be restarted manually.

1. Turn selector switch to automatic mode.
2. Close all filling valves.
3. Connect closed compressed air cylinders.
4. Open filling valves.
5. Start compressor by pushing the ON button.
6. When filling pressure gauge increases, open filling valves slowly.
7. Fill compressed air cylinders to the desired pressure, subsequently close filling valves slowly.
8. Close and vent all filling valves.
9. Disconnect all compressed air cylinders from filling valves.
10. If automatic operation is interrupted by:
 - pushing the OFF button
 - turning the selector switch
 - tripping the emergency shut-off switch
 - opening of the doors or the coverthe unit has to be restarted.



AUTO START FUNCTION

Spare part lists

| Best.-Nr. / Order No. | Benennung | Description |
|-----------------------|-----------------------------------|---------------------------------|
| 000203 | Druckschalter 50-350 bar | Pressure Switch 50-350 bar |
| 000652 | Manometer 0-400 bar | Pressure Gauge 0-400 bar |
| 000794 | T-Verschraubung mit fester Mutter | T-Connection with fixed nut |
| 001440 | Hochdruckschlauch 10L (1500mm) | High Pressure Hose 10L (1500mm) |
| 005812 | Manometerverschraubung | Pressure Gauge Connection |

D

AUTO START FUNCTION

Spare part lists

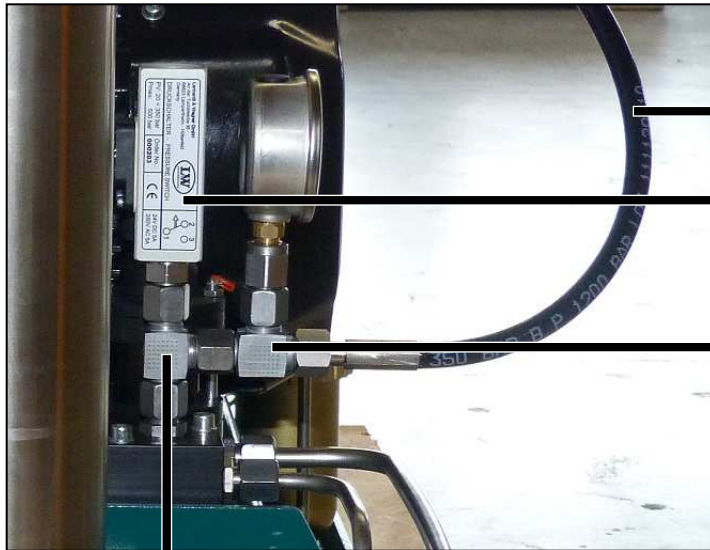

001440

000203

000794

000794

D



000652

005812



OIL PRESSURE GAUGE

D

OIL PRESSURE GAUGE

Oil pressure gauge

The oil pressure gauge shows the compressor oil pressure during operation. Oil pressure values at operating temperature should remain between:

- min. + 1.3 bar
- max. + 1.5 bar

If oil pressure value stays below the minimum value:

- Wrong compressor rotation direction (see rotation direction arrow)
- Oil level too low, not enough oil in the compressor
- Oil pump sieve contaminated
- Oil intake hose damaged / defective
- Oil temperature below +5 °C - lubrication not possible
- Oil temperature higher than +120 °C - oil viscosity too low
- Oil pump defective

If oil pressure value stays above the maximum value:

- Low oil temperature, between +5 °C and +10 °C
- Should stay within the range of tolerance when operation temperature is reached..

Oil pressure control

If oil pressure remains outside the range of tolerance, it can be adjusted at the oil pump.

Increasing oil pressure

- Turn adjusting screw clockwise

Reduce oil pressure

- Turn adjusting screw anti-clockwise



Warning

Only adjust the oil pressure at operating temperature!

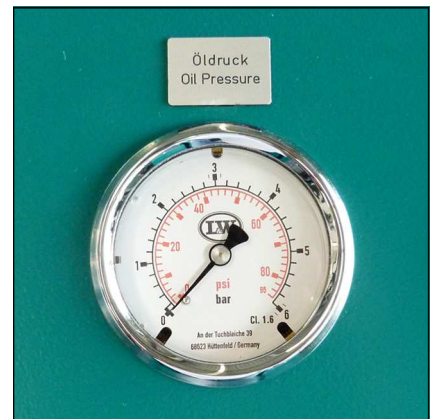

Oil pressure gauge

D



Adjusting the oil pressure

OIL PRESSURE GAUGE

Spare part lists

| Best.-Nr. / Order No. | Benennung | Description |
|-----------------------|-------------------|-------------------------|
| 000655 | Öldruckmanometer | Oil Pressure Gauge |
| 004169 | Manometerschlauch | Hose for Pressure Gauge |

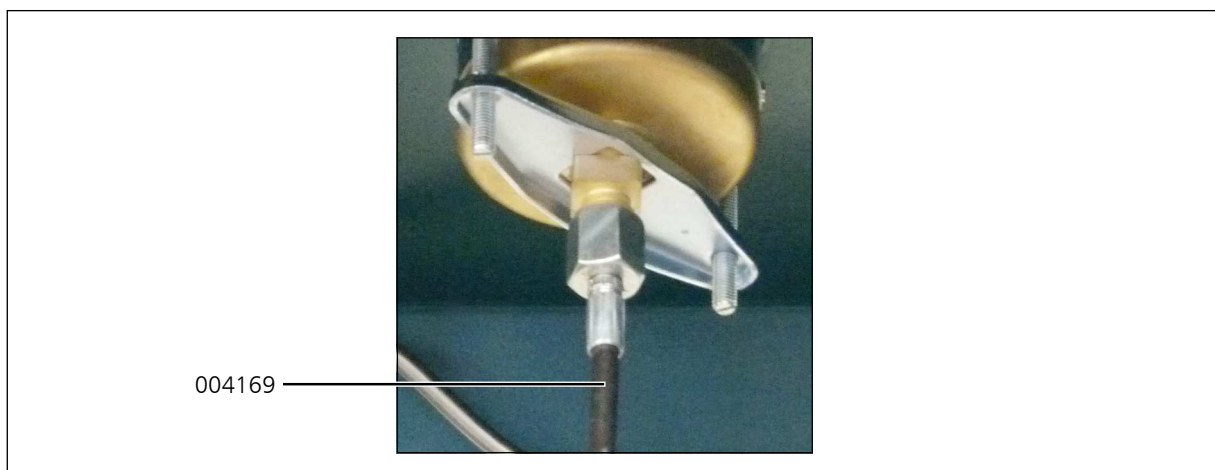
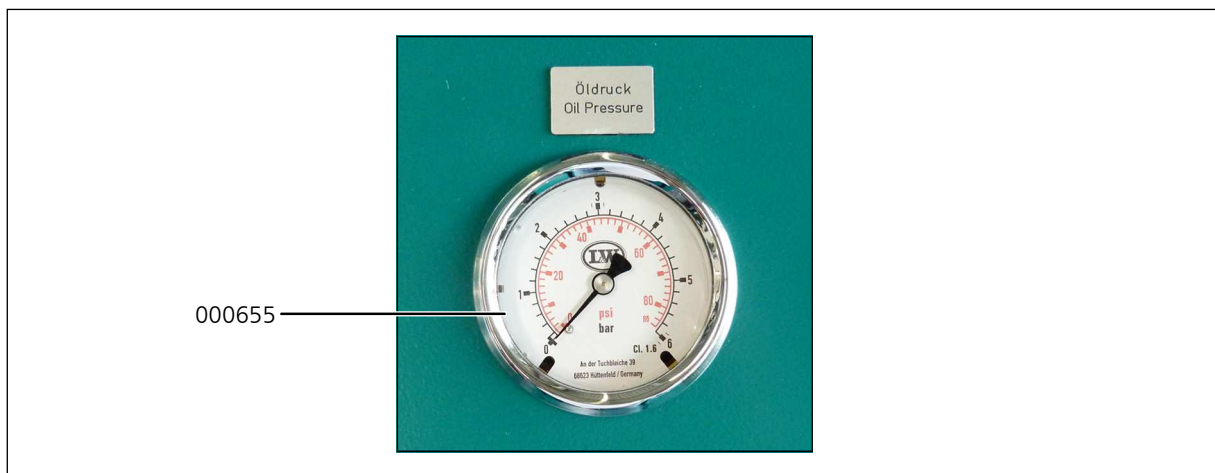

D



OIL PRESSURE MONITORING

D

OIL PRESSURE MONITORING

Oil pressure monitoring

The oil pressure is maintained by a pressure switch during operation. The compressor automatically shuts off when oil pressure decreases below the minimum pressure of +0.5 bar. The red warning lamp "Oil Pressure Monitoring" lights up.

Possible causes of fault:

- Wrong compressor rotation direction
(see rotation direction arrow)
- Oil level too low, not enough oil in the compressor
- Oil pump sieve contaminated
- Oil intake hose damaged / defective
- Oil temperature below +5 °C - lubrication not possible
- Oil temperature higher than +120 °C - oil viscosity too low
- Oil pump defective



Oil Pressure Monitoring

OIL PRESSURE MONITORING

Spare part lists

| Best.-Nr. / Order No. | Benennung | Description |
|-----------------------|----------------------|-------------------------|
| 004701 | Warnlampe | Warning Lamp |
| 004703 | Schild | Label |
| 004704 | Relais für Warnlampe | Relais for warning lamp |
| 006859 | Schildträger | Label holder |

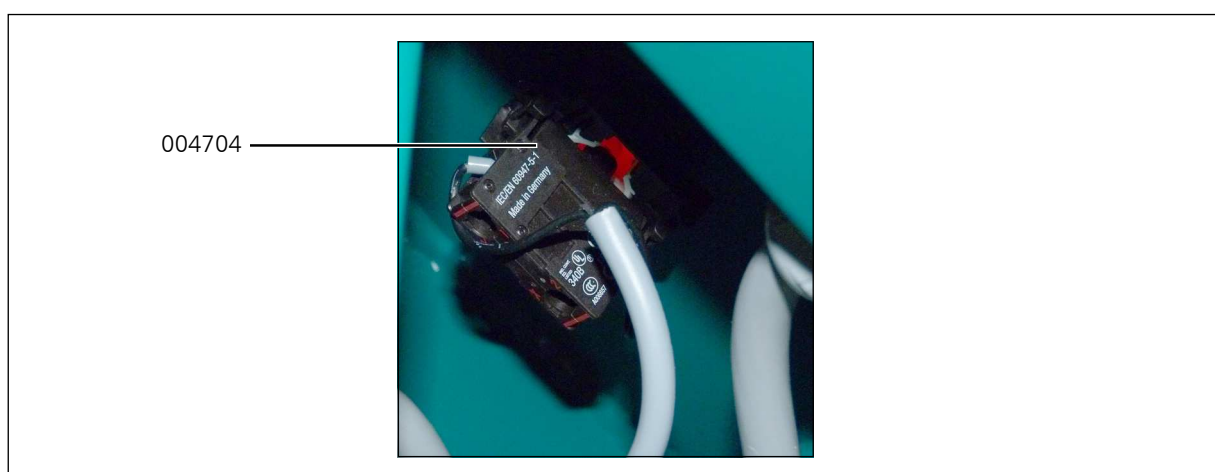



OIL PRESSURE MONITORING

Baugruppe: Öldrucküberwachung / Assembly: Oil Pressure Monitoring

| Best.-Nr. / Order No. | Benennung | Description |
|-----------------------|---------------------------------------|--------------------------------|
| 000655 | Einbaumanometer mit Befestigungsbügel | Press.Gauge, glycerine, brass |
| 000710 | Verschraubung | Connection w/o nut& olive seal |
| 000720 | Verschraubung | Connection with fixed nut |
| 000732 | Mutter | Union Nut 06L |
| 001022 | Zylinderschraube | Allen Bolt |
| 001176 | U-Scheibe A5 | Washer A5 |
| 001447 | Manometerschlauch 800mm | Pressure Gauge Hose |
| 002395 | Verschlusskegel 06mm | Locking cone 06mm |
| 005261 | Druckschalter inkl. Stecker | Oil Pressure Switch 0.2-2 bar |
| 008995 | Winkelverschraubung | Elbow Connection |
| 009243 | Öldruckleitung 6mm | Oil Suction Pipe |
| 009460 | Abstandhalter | Spacer |

D

OIL PRESSURE MONITORING

Baugruppe: Öldrucküberwachung / Assembly: Oil Pressure Monitoring

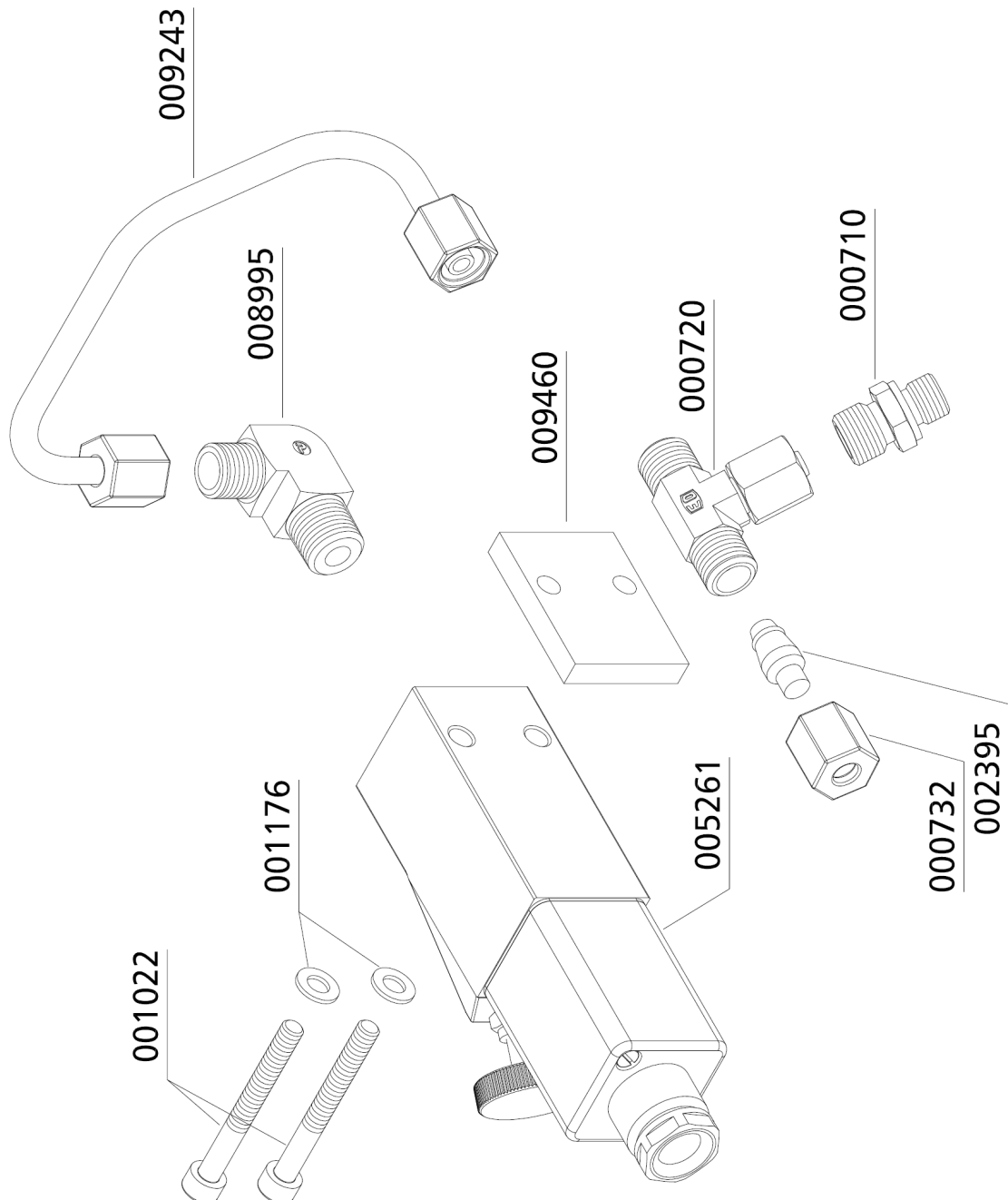

D

OIL PRESSURE MONITORING

Baugruppe: Öldrucküberwachung / Assembly: Oil Pressure Monitoring

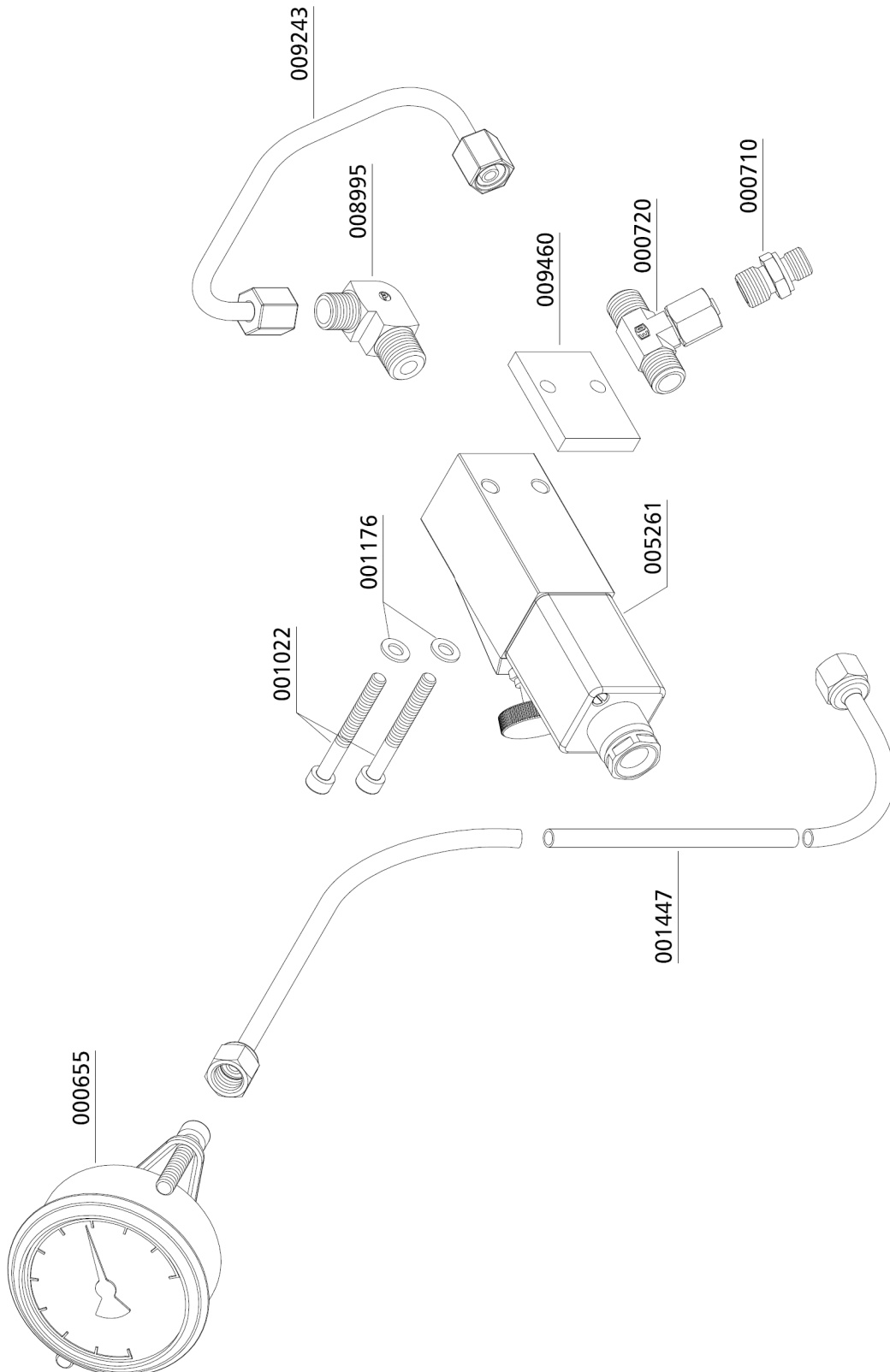

D



OIL TEMPERATURE MONITORING

D

OIL TEMPERATURE MONITORING

Oil temperature monitoring

Oil temperature monitoring

The oil temperature is maintained by a temperature sensor inside the compressor block during operation.

The compressor automatically shuts off when oil temperature exceeds the maximum pressure of +100 °C. The red warning lamp "Oil Temperature Monitoring" lights up.

Possible causes of fault:

- Ambient temperature too high
- Cooling air flow not sufficient
- Oil level too low
- Cooling pipes contaminated



Oil Pressure Monitoring



Warning

Risk of burns!

Allow the unit to cool before beginning troubleshooting.

OIL TEMPERATURE MONITORING

Spare part lists

| Best.-Nr. / Order No. | Benennung | Description |
|-----------------------|--------------------|--------------------|
| 004342 | Display | Display |
| 004730 | Display und Sensor | Display and Sensor |

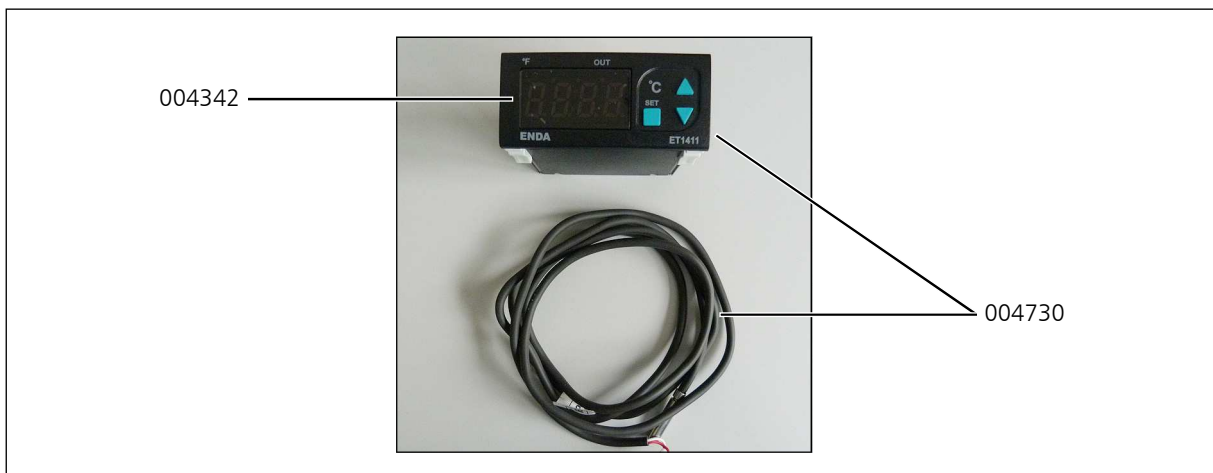

D



CYLINDER HEAD TEMPERATURE MONITORING

D

CYLINDER HEAD TEMPERATURE MONITORING

Cylinder head temperature monitoring

The cylinder head temperature is maintained by a temperature sensor at the cylinder head of the high pressure stage during operation. The compressor shuts off automatically when cylinder head temperature exceeds the maximum pressure of +120° C. The red warning lamp "Cylinder Head Temperature Monitoring" lights up.

Possible causes of fault:

- Ventilation of the compressor room is not sufficient
- Cooling air flow not sufficient
- Cooling pipes contaminated



Warning

Risk of burns!

Allow the unit to cool before beginning troubleshooting.

CYLINDER HEAD TEMPERATURE MONITORING

Spare part lists

| Best.-Nr. / Order No. | Benennung | Description |
|-----------------------|--------------------------------|------------------------------|
| 004726 | Display | Display |
| 005585 | Sensor | Sensor |
| 007613 | Ventilkopf (Spezielle Version) | Valve Head (special version) |

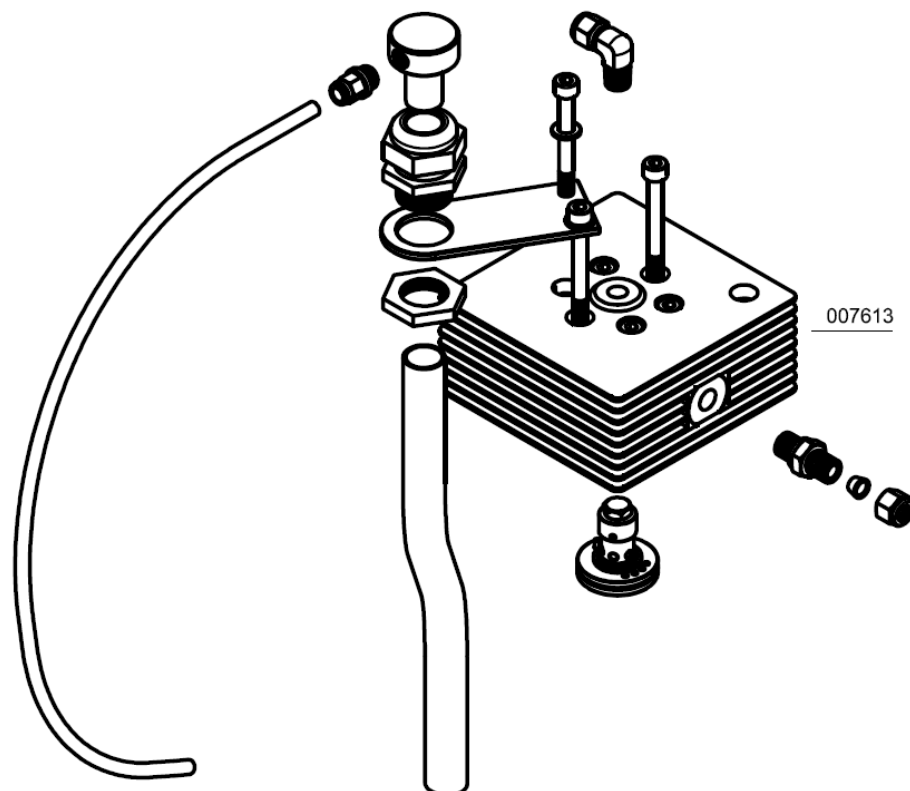
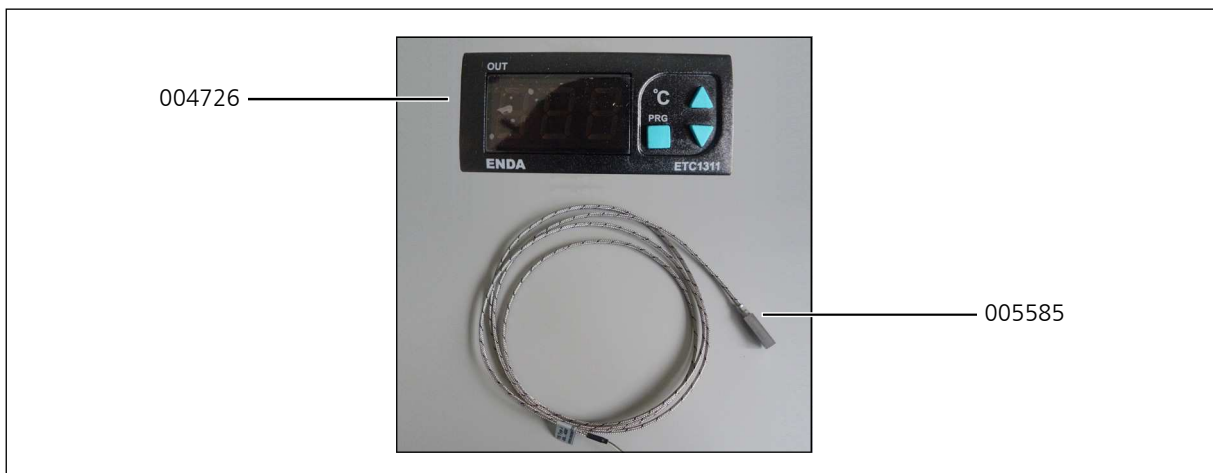

D



INTERSTAGE PRESSURE GAUGES

D

INTERSTAGE PRESSURE GAUGES

Interstage pressure gauges

Each of the 3 pressure stages is monitored by a single pressure gauge. This is serviceable for troubleshooting and allows detecting faults at an early stage.

Indicated interstage pressures depend on final pressure settings.

The pressure gauges should show the following values at a final pressure of 300 bar:

1. 3rd stage: approx. 4.2 bar
2. 3rd stage: approx. 42 bar
3. 3rd stage: approx. 300 bar

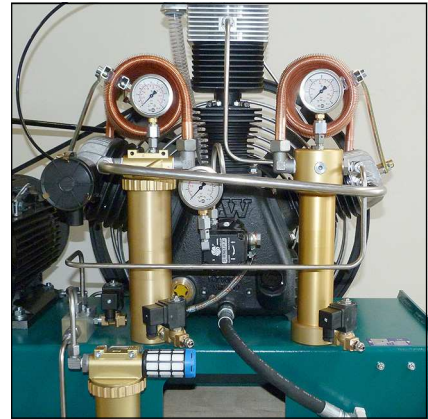

Interstage pressure gauges

INTERSTAGE PRESSURE GAUGES

Spare part lists

| Best.-Nr. / Order No. | Benennung | Description |
|-----------------------|------------------------|--------------------------|
| 000645 | Manometer 1. Stufe | Pressure gauge 1st stage |
| 000648 | Manometer 2. Stufe | Pressure gauge 2nd stage |
| 000710 | Gerade Verschraubung | Straight Connection |
| 000769 | Manometerverschraubung | Gauge connection |

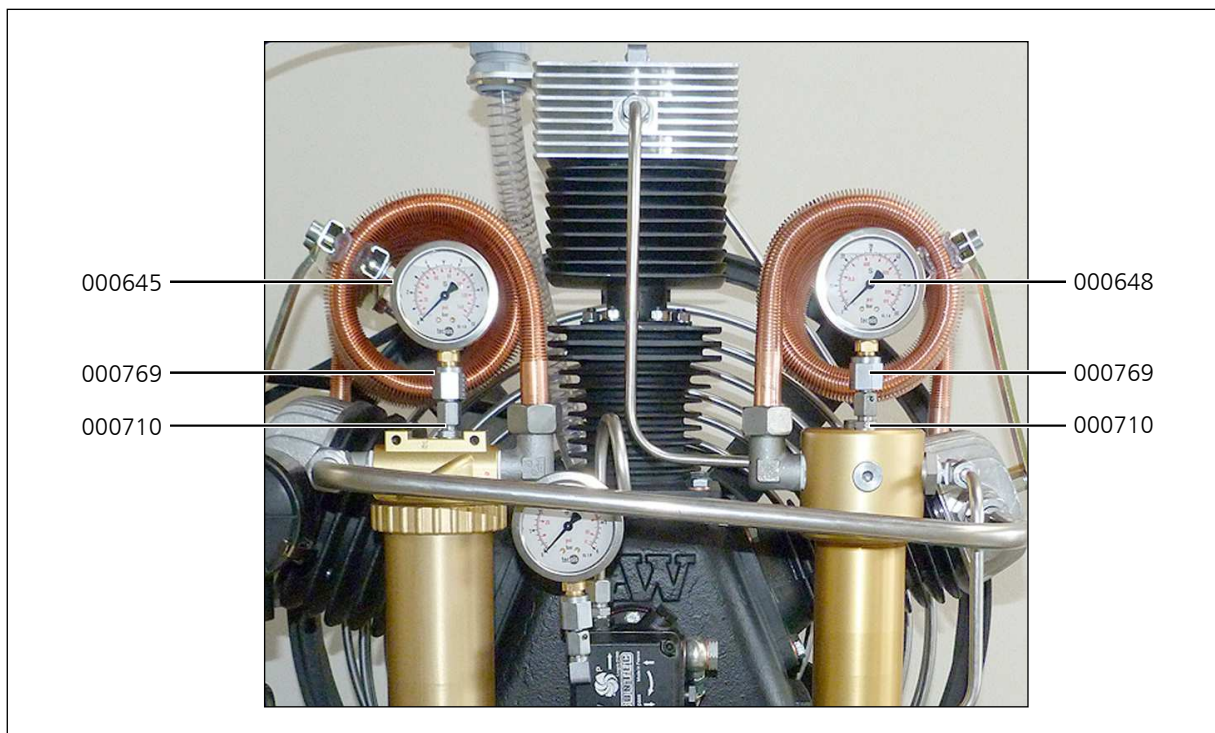



**200 / 300 BAR
PARALLEL FILLING
PRESSURE OPERATION**

D

200 / 300 BAR PARALLEL FILLING PRESSURE OPERATION

200 bar / 300 bar parallel filling pressure operation

This option allows the filling of 200 bar and 300 bar at once.

In this case, the compressor is equipped with a pressure reducer, a second final pressure safety valve and a second filling pressure gauge.

The handwheels (or bellows) are colour-coded to allow an optical differentiation:

- 200 bar: black
- 300 bar: red

Furthermore, the corresponding filling pressures at the compressor are marked with labels.



DIN handwheels 200 bar and 300 bar



Fig. Safety valve: 225 bar (left),
pressure reducer: 330 / 225 bar (right)

Füllschlauch / Filling Hose

| Best.-Nr. / Order No. | Benennung | Description |
|-----------------------|--|-------------------------------|
| 001440 | Hochdruckschlauch 10L, 1500 mm, starr | HP-Hose 10L 1500 mm, fixed |

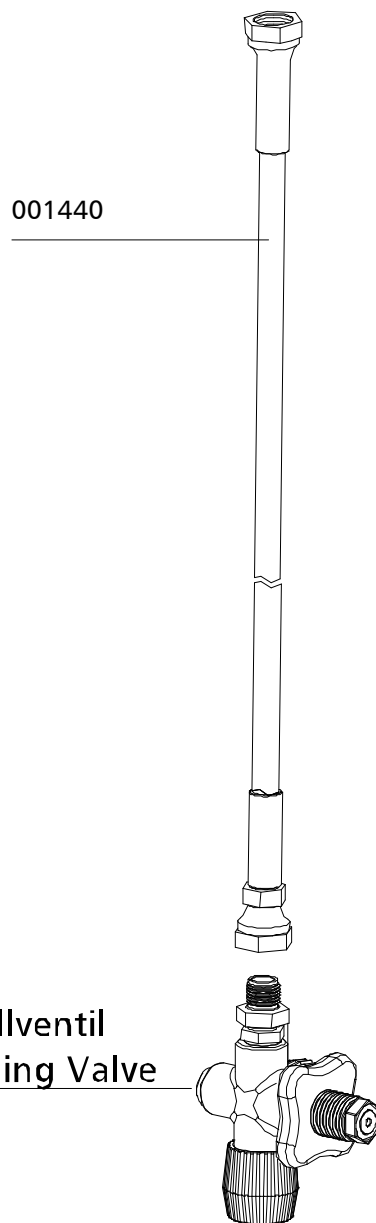

D



200 / 300 BAR PARALLEL FILLING PRESSURE OPERATION

Füllventil mit Manometer / Filling Valve with Pressure Gauge

| Best.-Nr. / Order No. | Benennung | Description |
|-----------------------|--|--|
| 000213 | Handrad, schwarz, 200/232 bar DIN, G 5/8" | Hand Wheel DIN 200 bar, black, G 5/8" |
| 000215 | Handrad rot, 300 bar DIN | Hand Wheel DIN 300 bar, red |
| 000386 | Gleitscheibe, Kreuzventil | Slide Washer |
| 000387 | Feder, Kreuzventil | Coil Spring, cross d. valve |
| 000666 | Manometerschutzkappe Ø63mm | Protector Pressure Gauge Ø63mm |
| 000696 | Füllanschluss o. Handrad, Messing verchr., 200 bar, AG M16x1,5 | Filling Connect. w/o handwheel. 200 bar, AG M16x1,5 |
| 000697 | Füllanschluss o. Handrad, ab 2005, 300bar,AG M16X1,5 für Schlauch | Filling Connec. w/o handwheel, 300bar, AG M16X1,5 hose |
| 000709 | Füllventil Kreuzbauweise, v2 x G1/4" IG, 1 x M16 x 1,5mm IG | Filling Valve cross design |
| 000785 | Verschraubung konisch, GE 10L R1/4" | Connection conical, GE 10L R1/4" |
| 001237 | O-Ring DIN Flaschenanschluss 200/300bar, 12,37x2,62 NBR90 | O-Ring DIN filling connector 200/300bar, 12,37x2,62 NBR90 |
| 001391 | O-Ring, Kreuzventil | O-Ring, / Cross design Filling Valve |
| 001392 | Füllhandrad Kreuzventil Ø35mm | Hand Wheel Filling Valve cross Ø35mm |
| 001393 | Entlüftungsspindel | Vent Spindle |
| 001394 | Entlüftungshandrad Ø27mm | Vent Hand Wheel Ø27mm |
| 001395 | Gleitscheibe, schwarz, Kreuzventil | Slide Washer, plastic black |
| 001397 | Kupferdichtung 8 x 14 x 1mm | Copper Seal Ring 8 x 14 x 1mm |
| 001398 | Madenschraube M3x8mm | Worm Screw M3x8mm |
| 001399 | Adapterwelle, Kreuzventil | Adapter Shaft |
| 001400 | Dichtspindel, Kreuzventil | Seal Spindle Filling Valve |
| 001401 | Schlitzmutter | Slotted Nut |
| 001402 | Klemmverschraubung, kompl. mit O -Ring | Filling Spindle Body, c/w O-rings |
| 004977 | Manometer, Edelstahl | Pressure Gauge, S/S |

D

200 / 300 BAR PARALLEL FILLING PRESSURE OPERATION

Füllventil mit Manometer / Filling Valve with Pressure Gauge

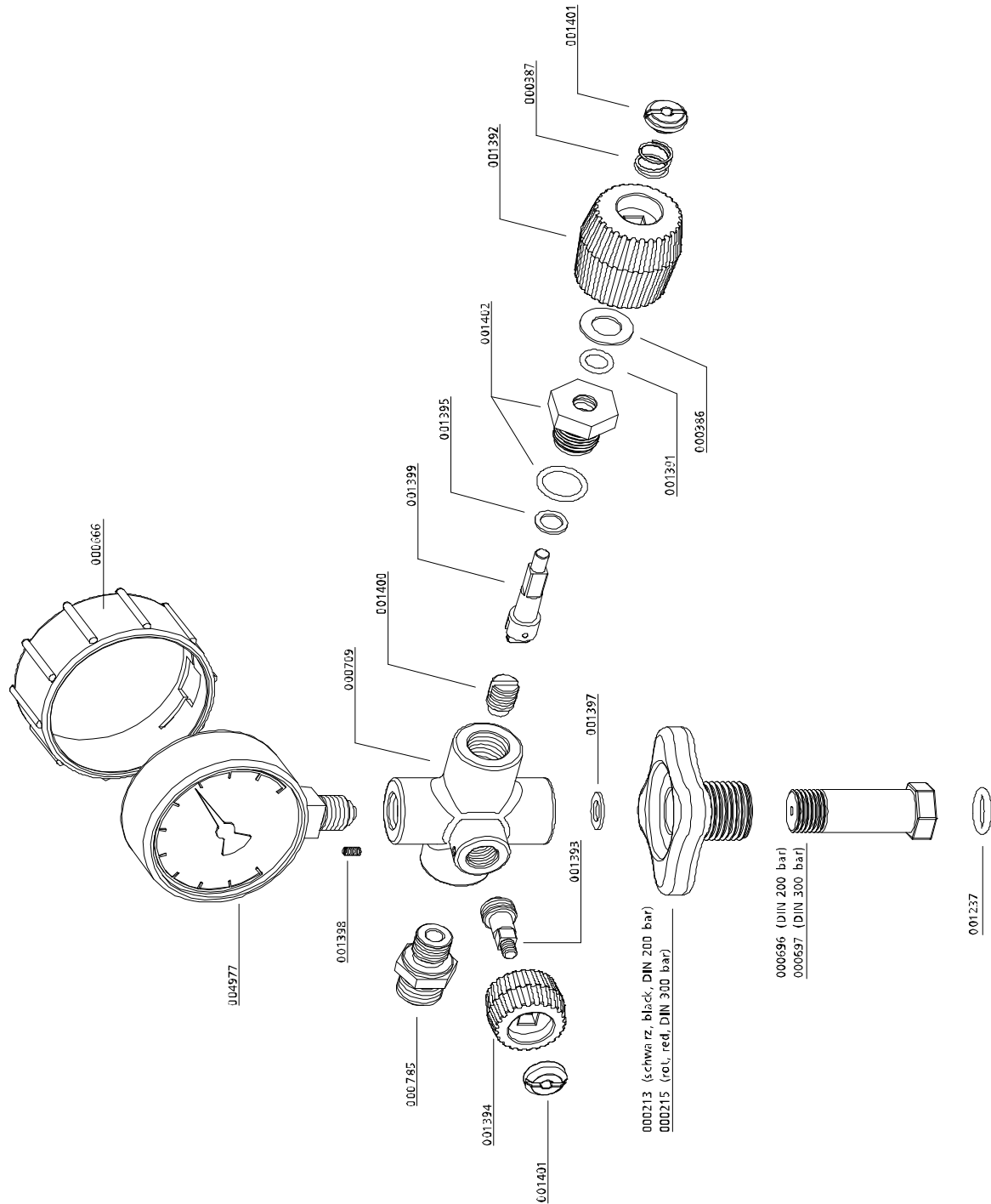



200 / 300 BAR PARALLEL FILLING PRESSURE OPERATION

Baugruppe: Verteilerblock / Assembly: Distributor Block

| Best.-Nr. / Order No. | Benennung | Description |
|-----------------------|---------------------------------------|---|
| 000210 | Verteilerblock, Al, 2 Druckbereiche | Distributor Block, alloy, dual pressure |
| 000498 | Unterlegscheibe A6 | Washer A6 |
| 000710 | Verschraubung ohne Mutter & | Connection w/o nut& olive seal, |
| 000721 | Verschraubung WE 06 PLR CFX 1/4" | Connection WE 06 PLR CFX 1/4" |
| 000732 | Mutter M06LCFX | Union Nut M06LCFX |
| 000733 | Schneidring SR06 | Olive Seal SR06 |
| 000738 | Verschraubung GE 08 PLR1/4" | Connection GE 08 PLR1/4" |
| 000750 | Verschraubung, EVGE 08 PSR-ED / G1/4 | Connection with fixed nut, EVGE 08 PSR- |
| 000761 | Verschraubung WE 08 PLR CFX 1/4" | Elbow connection WE 08 PLR CFX 1/4" |
| 000765 | Schneidring PSR 08 LX | Olive Seal PSR 08 LX |
| 000767 | Mutter M08 S A3C | Nut M08 S A3C |
| 000838 | Verschlussstopfen VSTI R1/4" EDCFX | Plug VSTI R1/4" EDCFX |
| 001048 | Zylinderschraube M6x10 DIN 912 8.8 ZN | Allen Screw M6x10 DIN 912 8.8 ZN |
| 001428 | Druckminderer "High Flow" einstellbar | Pressure reducer - bolt version |
| 003182 | Rohrleitung | Pipe |
| 004932 | Verschraubung MAV 1/4"NPT / 8S, für | Connection MAV 1/4"NPT / 8S, for |

D

200 / 300 BAR PARALLEL FILLING PRESSURE OPERATION

Baugruppe: Verteilerblock / Assembly: Distributor Block

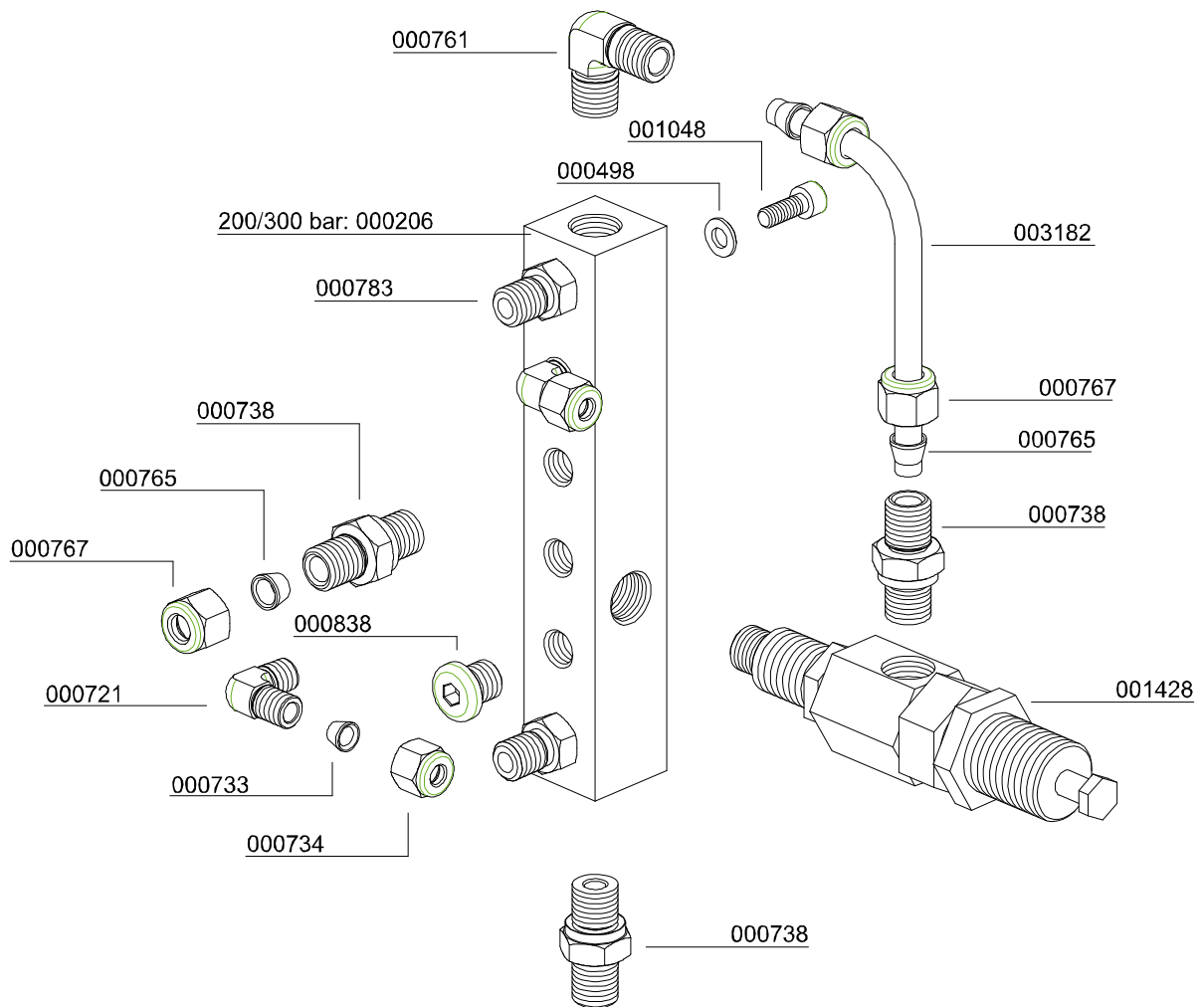

D



AIR COOLER CONNECTION KIT

D

AIR COOLER CONNECTION KIT

Air cooler connection kit

The Air Cooler Connection Kit provides an easy connection and a simple and time-saving installation or backfitting.

The piping inside the compressor is completely installed. Just disconnect the U-connection at the outside and connect the air cooler according to the connection designation (inlet/outlet).

To operate the unit without air cooler, reinstall the U-connection and the compressor is ready for use.

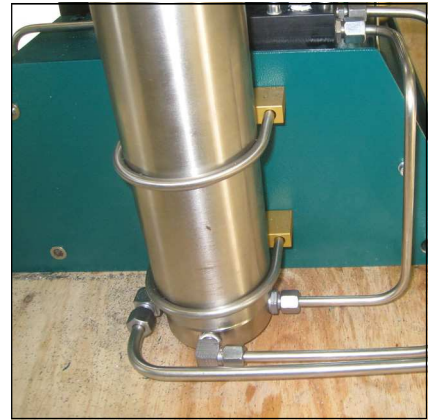

Air cooler connection kit

AIR COOLER CONNECTION KIT

Spare part lists

| Best.-Nr. / Order No. | Benennung | Description |
|-----------------------|----------------------|---------------------|
| 000783 | Gerade Verschraubung | Straight Connection |
| 000796 | Winkelverschraubung | Elbow Connection |
| 006928 | Rohrleitung | Connecting Pipe |

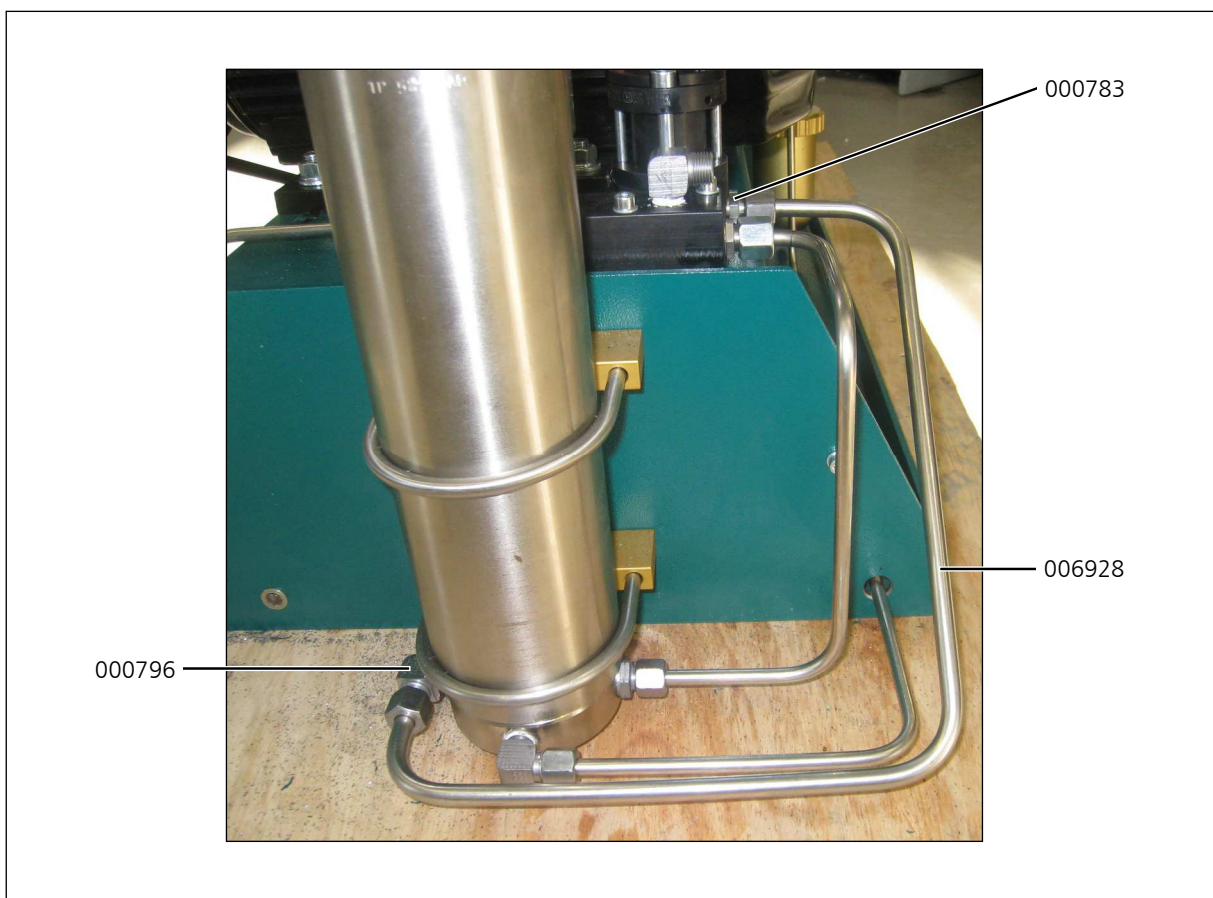

D



CONDENSATE TANK 60 LTR.

D

CONDENSATE TANK 60 LTR.

The 60 ltr. tank is equipped with an active carbon filter to collect condensate odourlessly and quietly. The condensate can be easily transported in the collecting tank and disposed environmentally sound.

The flexible connection hoses are fitted with quick-couplings, to allow easy separation from the compressor. The tank is equipped with a level gauge to indicate max. filling level. Two sturdy carrying handles ensure a safe transportation.

Technical Data:

- Dimensions: Ø 400 mm x 800 mm
- Weight: 20 kg



D

CONDENSATE TANK 60 LTR.

Maintenance and service

How to change the activated carbon and the metal filter insert

- Shut down the unit
- Plug out the condensate hoses
- Remove the protector cap, the nut and the allen bolts (Fig. 1)
- Take down the cover plate and the upper felt. Tip out the activated carbon and replace the lower felt
- Fill up the activated carbon and cover it with a new felt
- Put on the cover plate, screw the allen bolts and the nut and plug on the protector cap
- Unscrew the filter housing
- Remove the floater and the lower cover plate (Fig. 2)
- Take a pliers and pull the metal filter out of the metal case
- Insert the metal filter
- Install the cover plate and the floater
- Screw the filter housing onto the tank
- Plug in the condensate hoses

Maintanance intervals

We recommend to change the activated carbon if it has reached the saturation level (smell of oil).

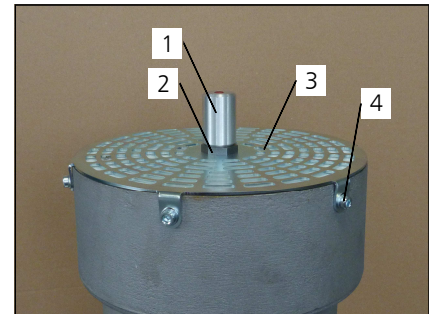

Fig. 1

- 1 Protector cap
- 2 Nut
- 3 Cover plate
- 4 Allen bolts (6x)

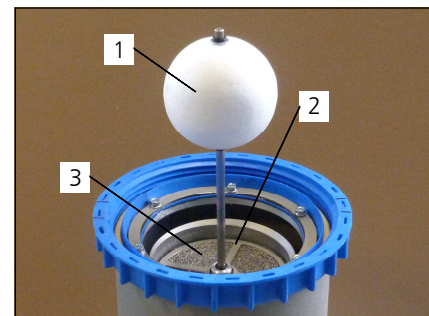

Fig. 2

- 1 Floater
- 2 Lower cover plate
- 3 Metal filter

CONDENSATE TANK 60 LTR.

Spare part lists

| Best.-Nr. / Order No. | Benennung | Description |
|-----------------------|---|-----------------------------------|
| 003091 | Kondensatbehälter 60 Liter | Condensate Tank 60L |
| 004056 | Kondensatschläuche Kondensatbehälter 60L, für 3- | Set of condensate hoses, 3 stages |
| 004057 | Kondensatschläuche Kondensatbehälter 60L, für 4- | Set of condensate hoses, 4 stages |

D

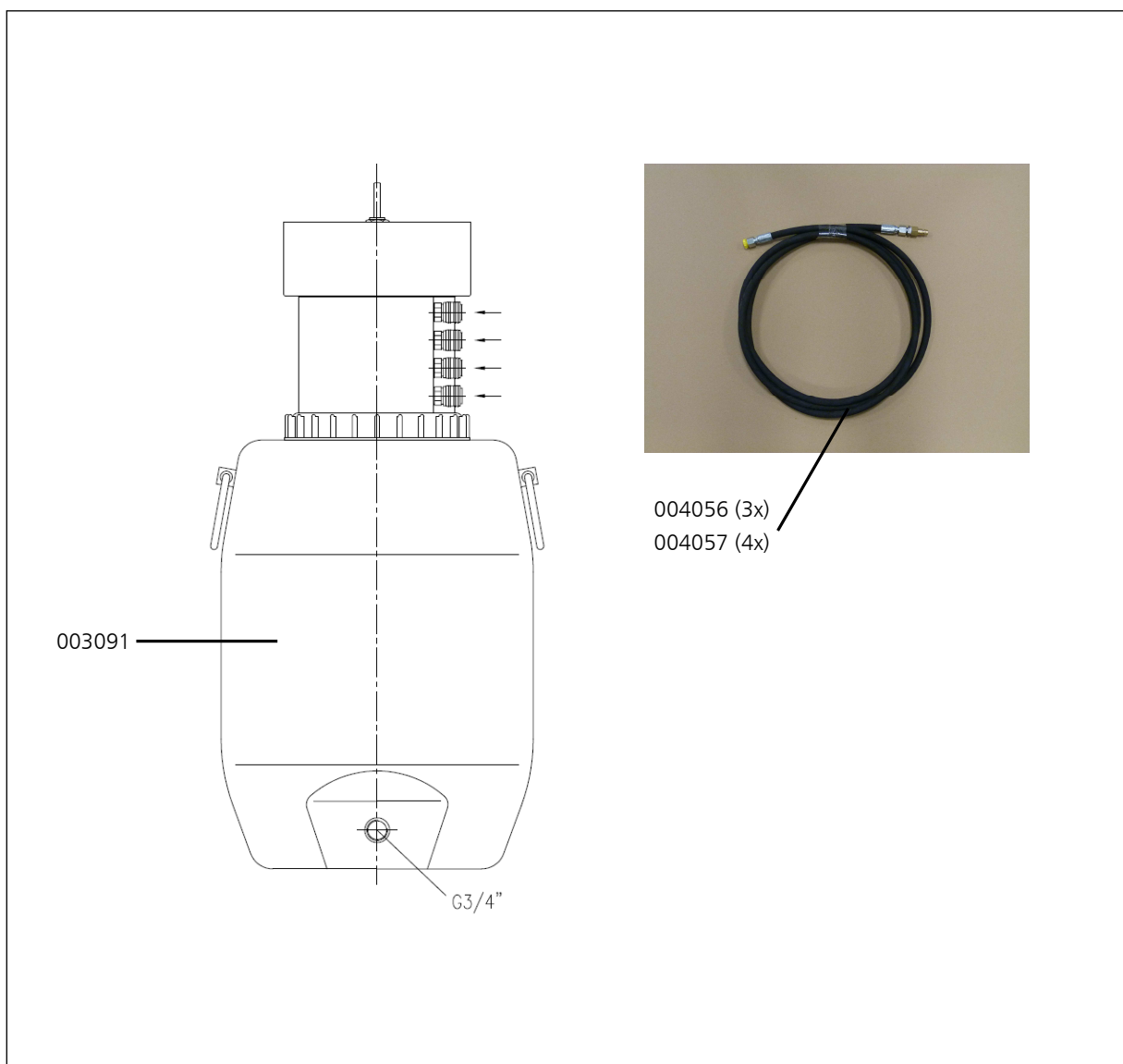

CONDENSATE TANK 60 LTR.

Spare part lists

| Best.-Nr. / Order No. | Benennung | Description |
|-----------------------|---|------------------------------------|
| 000508 | USIT-Ring 13,7 x Ø20 x 1,5 | Gasket Ring U-Sit 13,7 x Ø20 x 1,5 |
| 003866 | Filter Nachfüllset für 60 Liter | Filter refill set 60 ltr |
| 004789 | Schnellkupplung G1/4", DN 7,2 | Quick connector G1/4", DN 7,2 |
| 006642 | Metallgestrick für Kondensatbehälter 60 ltr | Metal filter insert 60 ltr tank |

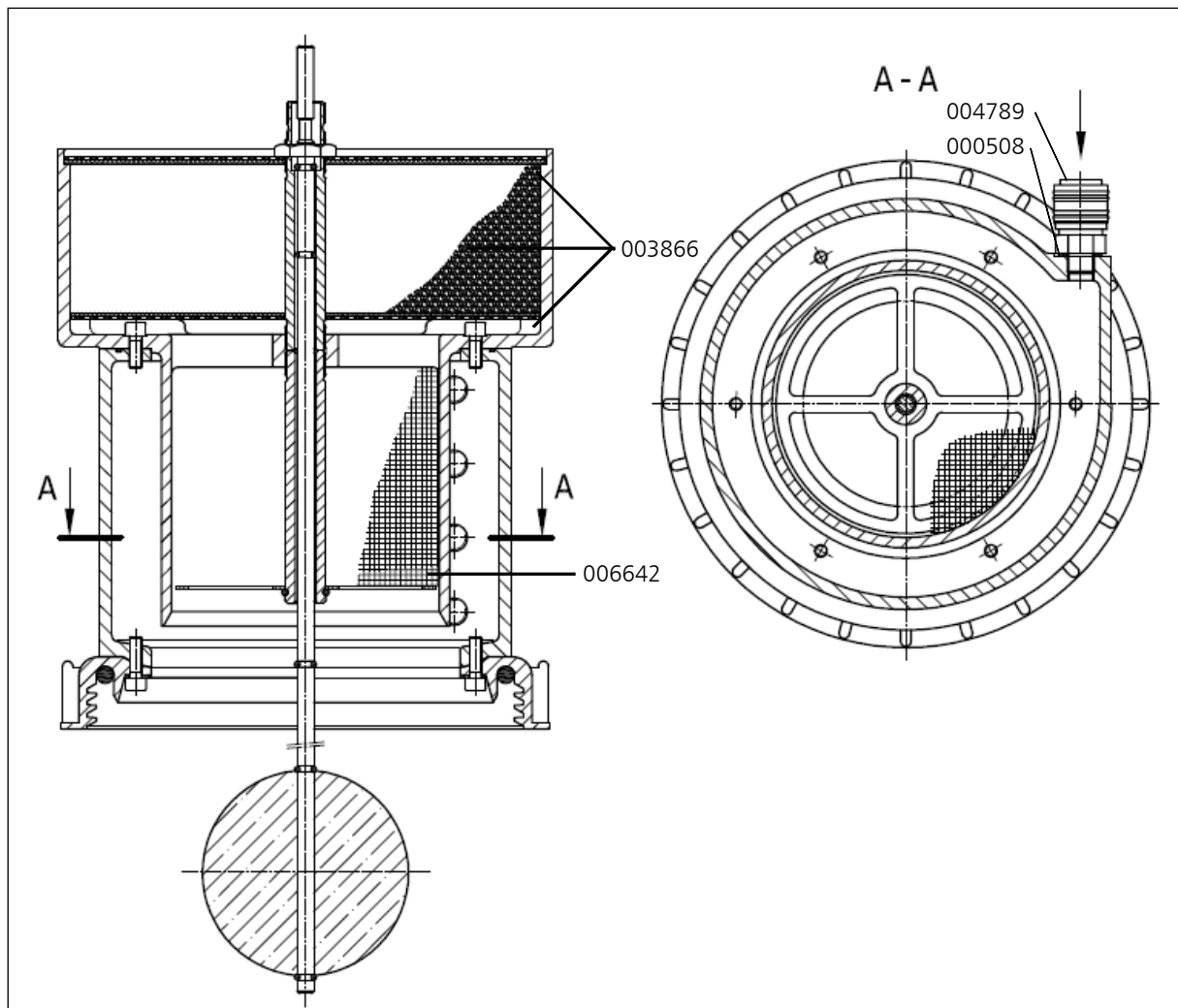

D



ATTACHMENT

E

Lenhardt & Wagner GmbH

**An der Tuchbleiche 39
D-68623 Lampertheim – Hüttenfeld**

www.lw-compressors.com



Operating Instruction

Safety valve

Typ:

SiV2 BKZ 989 TÜV.SV.12-989.5.G.V.P CE 0091 AlMgSi1 F31 1100* Lenhardt & Wagner

SiV BKZ TÜV.SV.14-1140.5.G.V.p CE 0091 AlMgSi1 F31 1100* Lenhardt & Wagner

| | |
|-------------------------|--|
| Set pressure: | see mark (hand wheel on top of valve) |
| Maximum outflow: | Set pressure 100-159 bar: 750 l / min Set pressure 160-350 bar: 1.100 l / min |
| Suitable media: | Media-resistant, non-corrosive gases |

The safety valve is used for protection of pressurized components, eg pipelines, pressure vessels, or the compressor itself.

The hand wheel on the top of the safety valve is marked with the adjusted set pressure.



- 1) *Identification of set pressure*
- 2) *Seal*
- 3) *Fixing screws¹*
- 4) *Venting screw (hand wheel)*
- 5) *Identification serial number*
- 6) *Socket for safety valve*

Safety valve with socket

¹ und die Anforderungen des AD 2000 Merkblatts W7 erfüllen. Schaftlänge 70mm. The fixing screws M8 must be strength class 8.8 and meet the requirements of Merkblatt AD 2000 leaflet W7. Shaft length 70mm.

In order to prevent manipulation of the set pressure, all safety valves are factory fitted with a seal.

A safety valve on which the seal has been removed, must be returned before further use to the manufacturer for repair / adjustment.

In addition, the safety valve has a venting device (hand wheel).

In the rotation direction clockwise, the safety valve and herewith also the filter housing of the final stage could be completely vented.

During normal operation, the screw is unscrewed to the upper stop anticlockwise, an integrated safety ring prevents that the screw can be completely unscrewed.

If a safety valve blow off, the system must be switched off immediately and investigate the cause of the error.

There are two possible reasons:

1. The safety valve is defective and blows off before the set pressure.

In this case the safety valve should be submitted immediately to the manufacturer for repair or replaced with a new one.

2. The safety valve opens properly, the problem is on the system.

A constant blowing of the safety valve is not permitted, the sealing seat of the valve can be damaged. The error on the system must be detected and repaired before further filling operations.

The safety valve may only be used if it is ensured that the maximum flowrate of the system does not exceed the blowoff rate of the safety valve.

The safety valve may only be used with the approved media.

Repair work on compressors must only be performed by trained personnel.

Dismantling of the safety valve

Ensure that on the safety valve is no pressure.

Loosen and remove the two M8 fixing bolts with a 6mm Allen key.

The safety valve can now be removed by turning and simultaneously pulling out of the socket.

Mounting

1. Clean the safety valve socket.

2. Oil the insert pin of the safety valve including the O-ring with 1 to 2 drops of oil.

3. Press the safety valve pin complete into the socket.

4. Fasten the safety valve with the two 8 mm allen screws into the socket

(Tightening torque: 10 Nm)

5. Screw the venting screw (hand wheel) anticlockwise to its upper limit.

6. Start the System (Compressor), check installation for leaks and proper function.

Manufacturer: Lenhardt & Wagner GmbH
An der Tuchbleiche 39
D-68623 Lampertheim – Hüttenfeld

Kontakt: E-Mail: service@lw-compressors.com
Web: www.lw-compressors.com
Tel.: +49 (0) 6256 – 85880 0
Fax: +49 (0) 6256 – 85880 14

Note:

*Use the safety valve only in a technically perfect condition, for its intended purpose, safety and danger awareness, in compliance with the operating instructions!
Especially disorders which could affect safety must be remedied immediately!*

Notes:

- The safety valve must be installed directly on the protected pressure vessel and / or the plant.
 - The safety valve must be installed in an upright position.
 - The flow area of the port must be greater than the valve opening.
 - Protect valve against splashes
-

Maintenance:

- The safety valve is periodically - in accordance with the currently valid Pressure Equipment Directives - to check on operation and reliability.
- Refill annually lubricating oil:
Oil filling position:
Hole on the spacer (see arrow, Figure 1)
- Oil level: Fill oil into the hole until oil comes out of the hole.

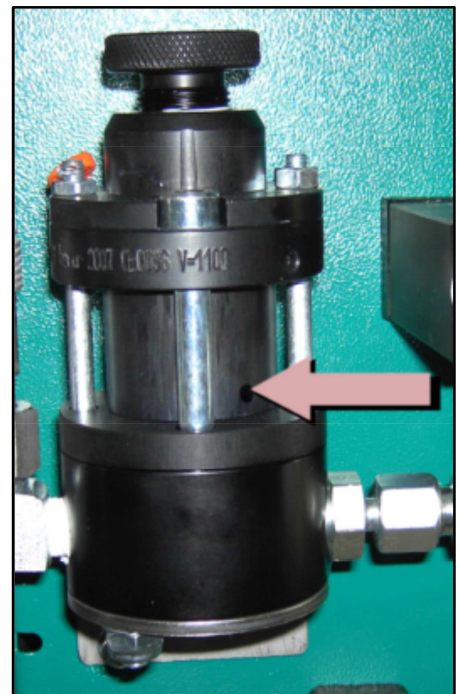

Figure 1: Position for oil refill

To be used lubricating oil for the safety valve: L&W Article Nr.: 008500 (content: 30 ml)
