



CHAPTER OVERVIEW

Operating Instructions

A

ECC - Electronic Compressor Control (if equipped).....

B

Spare Parts Lists

C

Options (if equipped).....

D

Attachment

E

Manufacturer in terms of 97/23/EC

The full name and address of the manufacturer is:

Lenhardt & Wagner GmbH

An der Tuchbleiche 39

68623 Hüttenfeld / Germany

Phone: +49 (0) 62 56 - 85 88 0 - 0

Fax: +49 (0) 62 56 - 85 88 0 - 14

E-Mail: service@lw-compressors.com

Internet: www.lw-compressors.com





SERVICE INFORMATION / WARRANTY

Compressor information

Type designation

Serial number

Date of construction

Purchase information

Purchase date

First commissioned on

Warranty period

Dealer's stamp

Warranty

L&W will uphold warranty claims made during a period of 12 months from the invoice date.

If the compressor was purchased from an official L&W dealer, the date on the dealer's invoice is valid. Warranty claims can only be made on presentation of the original invoice.

Should verifiably defective parts have been delivered, we will decide to either replace the parts or repair them. The resulting transport and assembly costs will be invoiced.

No reduction of the purchase price or changes to the contract can be made. The parts for which a claim is being made should be kept safe by the purchaser and, when requested, sent to us at their cost. Replaced parts become the property of L&W. If maintenance work is carried out without our knowledge or permission by the purchaser or a third party, we are absolved from any liability for warranty claims. As a matter of principle, warranty claims can only be made by the initial purchaser.

Operating Instructions

Breathing Air Compressor

LW 570 E Compact

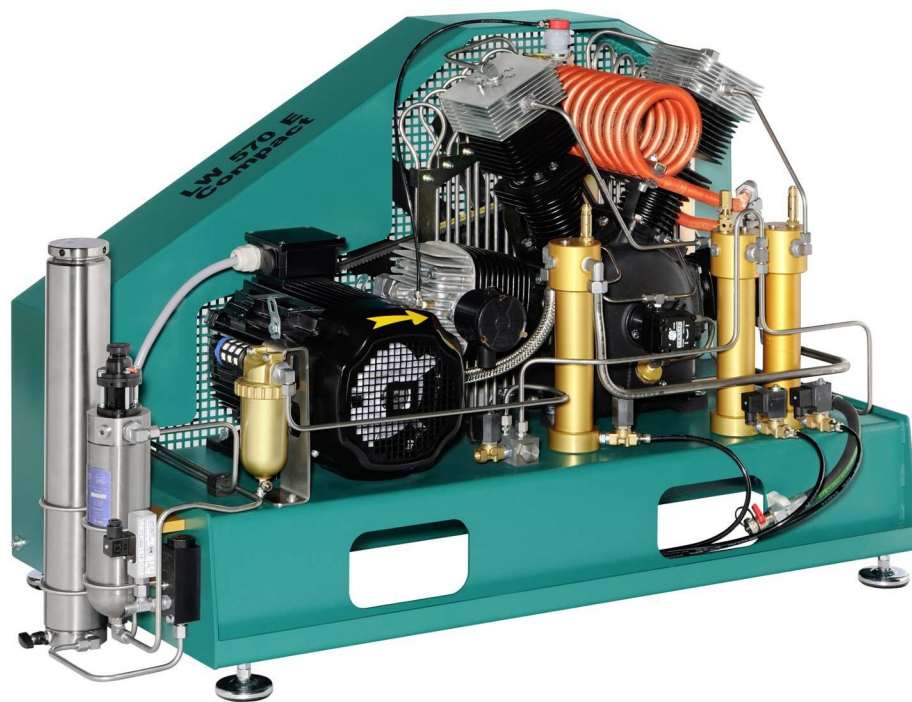



TABLE OF CONTENTS

General Information and Technical Data

General Information / Description of Warning Symbols	4
Scope of Delivery	5
Technical Data	6
Unit Assembly	7
Switchboard	8
Flow chart	9

Safety Precautions

Intended Use / Operators	11
Safety instructions on the unit	12
General Safety Precautions	13
Unit customised safety notices	14
Maintenance instructions	15
Transportation instructions / Safety regulations	16

Installation

Installation in closed rooms	18
Dimensions	19
Minimum distances	20
Ventilation	21
Electrical Installation	22 - 23

Operation

Important operation instructions	25
First commissioning	26 - 28
Daily commissioning	29
Filling procedure	30
Switch off the compressor	31

Remedying faults	32 - 36
-------------------------------	---------

Maintenance and Service

Service, Repair and Maintenance	38
Maintenance Lists / Maintenance Intervals	39 - 42
Service Kits	43
Check V-belt tension / Tension V-belt	44
Compressor lubrication / Check oil level	45
Oil change	46
Oil sieve change	47

A



TABLE OF CONTENTS

Maintenance and Service

Manual condensation dump system	48
Oil / water separators 1st, 2nd and 3rd stage - maintenance	49
Filter housing / Filter cartridge	50
Filter cartridge change.....	51
Filter housing - Maintenance	52
Inlet filters / Inlet filter cartridge change	53
Cylinder heads and valves	54
Replace inlet and outlet valves 1st and 2nd stage	55 - 56
Replace inlet and outlet valves 3rd and 4th stage	57
Safety valves	58
Pressure maintaining / non return valve	59
Safety valve test	60
Leak test	61
Pressure gas vessel test	62
Maintenance records	63 - 68

Storage

Conservation / storage of the compressor	69
De-conservation, commissioning	69
Transportation instructions / Disposal	70

A

GENERAL INFORMATION

General Information

We strongly recommend reading this manual thoroughly prior to operation and follow all the safety precautions precisely. Damage resulting from any deviation from these instructions is excluded from warranty and liability for this product. Carry out other commissioning steps only if you have fully understood the following contents.

Before commissioning and using the unit, carry out all the essential preliminary work and measures concerning legal regulations and safety. These are described on the following pages of this operation manual.

A

Description of marks and warning signs

The following warning signs are used in this document to identify the corresponding warning notes which require particular attention by the user. The warning signs are defined as follows:



Caution

Indicates an imminently hazardous situation which, if not avoided, could result in serious injury, physical injury or death.



Warning

Indicates a potentially hazardous situation which, if not avoided, could result in physical injury or damage to the product or environment.



Note

Indicates additional information on how to use the unit.



DESCRIPTION

Scope of Delivery

Compressors are provided in different equipped versions.

Versions

Filling pressure versions:

- PN 225 bar
- PN 330 bar
- PN 225 / 330 bar

Specifications

- Electro motor
- Painted steel frame and fan belt guard (RAL 6026)
- Hour counter
- Start/ Stop and emergency stop switch
- Manual condensate drain
- 1 x Filling hose c/w filling valve
- Motor protection switch
- Pressure maintaining and non return valve
- All pistons c/w steel piston rings
- Low pressure oil pump and filter
- Oil- / Water separators in stainless steel
- Safety valves after each stage
- 4 x concentric suction/pressure valves
- Filling pressure to your choice (200 or 300 bar)
- Connections to your choice (DIN 200 bar or 300 bar, CGA 200 bar or 300 bar and INT)
- Breathing air purification an accordance to EN 12021

Options

- Automatic condensate drain
- Automatic stop at final pressure
- Auto start system
- 200 and 300 bar parallel filling pressures
- Oil pressure gauge and intermediate pressure gauges
- Oil pressure monitoring c/w auto shut down
- Cylinder head temperature monitoring with auto shut down
- Puracon filter monitoring (Auto shut down also available)
- Phase monitoring c/w shut down at wrong direction of rotation
- Additional high pressure outlet
- Power cable and plug
- Block heating device
- 420 bar Version
- 2.3 ltr. Filter housing
- 0.8 ltr. Prefilter (Enlarged the lifetime of the filter by approx. 5 hours)
- Special voltages / frequencies on request

DESCRIPTION

Technical Data



Technical Data	LW 570 E Compact
Capacity [l/min]:	570
Max. Operating Pressure [bar]:	350
RPM [min ⁻¹]:	1,100
Number of Pressure Stages:	4
Cylinder Bore 1st Stage [mm]:	Ø 105
Cylinder Bore 2nd Stage [mm]:	Ø 50
Cylinder Bore 3rd Stage [mm]:	Ø 25
Cylinder Bore 4th Stage [mm]:	Ø 14
Medium:	Compressed Air / Breathing Air
Intake Pressure:	atmospheric
Oil Pressure (at operating temperature) [bar]:	+1.5 (+0,2)
Oil Capacity [l]:	2.5
Intake Temperature [°C]:	0 < +45
Ambient Temperature [°C]:	+5 < +45
Cooling Air Volume 50 / 60 Hz [m ³ /h]:	> 4500 / 5400
Voltage:	400 V / 3 phase / 50 Hz
Protection Class Drive Motor:	IP 54
Drive Power 50 / 60 Hz [kW]:	15 / 18
RPM Motor [min ⁻¹]:	2,890
Start:	Star/Delta
Noise level [dB(A)]:	83 from a distance of 1 m
Dimensions W x D x H [mm]:	1300 x 720 x 1000
Weight [kg]:	approx. 365
Content Volume Filter housing [l]:	1.7

DESCRIPTION

Unit Assembly

A

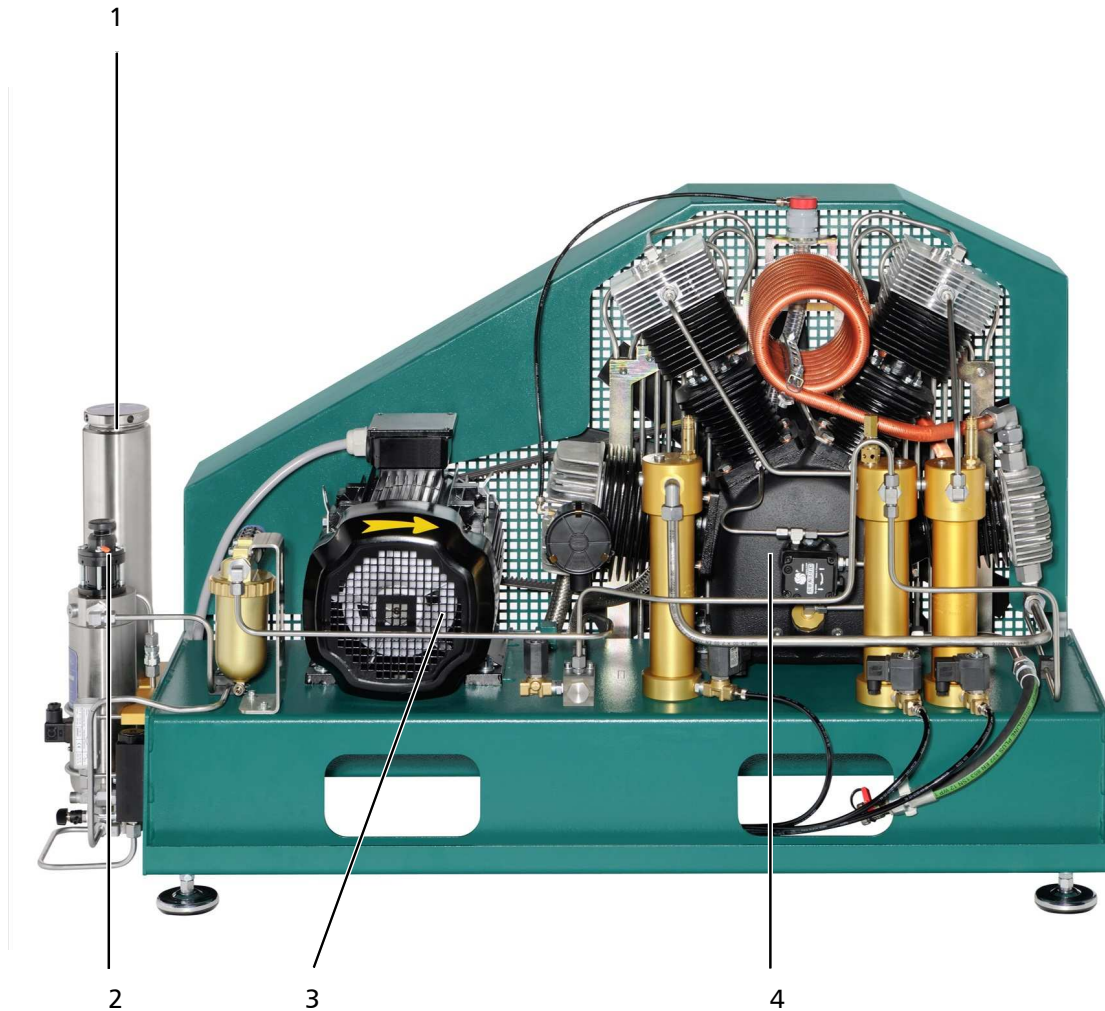

No.	Designation
1	Filter housing
2	Final pressure safety valve
3	Motor
4	Filling valves

DESCRIPTION

Switchboard

A



No.	Designation
1	Emergency shut-off switch
2	Hour counter
3	ON button
4	OFF button
5	Drain test button

DESCRIPTION

Flow chart

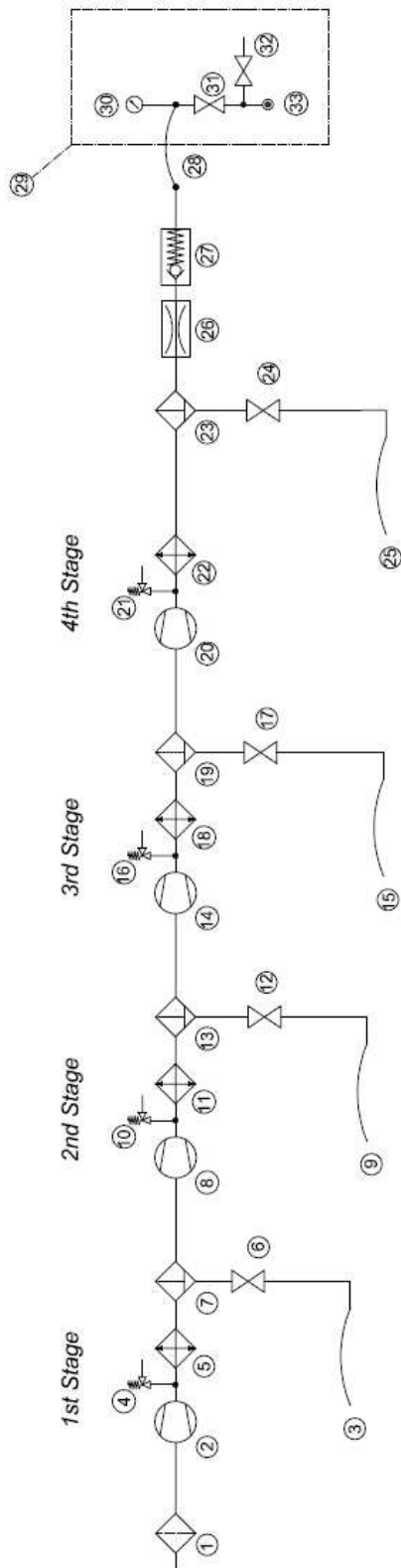

- | | | |
|-----------------------------------|-----------------------------------|--|
| 1. Air Intake Filter | 13. Oil Water Separator | 25. Condensate Drain Hose |
| 2. 1st Pressure Stage | 14. 3rd Pressure Stage | 26. Pressure Maintaining Valve |
| 3. Condensate Drain Hose | 15. Condensate Drain Hose | 27. None Return Valve |
| 4. Safety Valve 1st Stage | 16. Safety Valve 3rd Stage | 28. Filling (HP-) Hose 10L—M16x1.5 female—1500mm |
| 5. Heat Exchanger | 17. Manual Condensate Drain Valve | 29. Cross Desing Filling Valve |
| 6. Manual Condensate Drain Valve | 18. Heat Exchanger | 30. Final Pressure Gauge |
| 7. Oil Water Separator | 19. Oil Water Separator | 31. Filling Valve |
| 8. 2nd Pressure Stage | 20. 4th Pressure Stage | 32. Vent Valve |
| 9. Condensate Drain Hose | 21. Safety Valve 4th Stage | 33. Filling Connector (5/8" male) |
| 10. Safety Valve 2nd Stage | 22. Heat Exchanger | |
| 11. Heat Exchanger | 23. Oil Water Separator | |
| 12. Manual Condensate Drain Valve | 24. Manual Condensate Drain Valve | |

A



A

SAFETY PRECAUTIONS



SAFETY PRECAUTIONS

Intended Use

Only use the unit in perfect condition for its intended purpose, safety and intended use and observe the operating instructions! In particular disorders that may affect safety have to be eliminated immediately!

Use the unit exclusively for the determined medium (see "Technical Data"). Any other use that is not specified is not authorized. The manufacturer/supplier shall not be liable for any damages resulting from such use. Such risk lies entirely with the user. Authorization for use is also under the condition that the instruction manual is complied with and inspection and maintenance requirements are enforced.

No change and modification to the unit can be made without the written agreement of the manufacturer. The manufacturer is not liable for damage to persons or property resulting from unauthorized modifications.

Operators

Target groups in these instructions;

Operators

Operators are persons who are authorized and briefed for the use of the compressor.

Qualified personnel

Qualified personnel are persons who are entitled to repair, service, modify and maintain the system.



Warning

Only trained personnel are permitted to work on the unit!



Warning

Work on the electrical equipment on / with the machine / unit may only be carried out by qualified electricians.

SAFETY PRECAUTIONS

Safety instructions on the unit

Importance of notes and warning signs that are affixed to the compressor according to the application or its equipment.

A



Warning
High voltage!



Note
Ensure correct direction of rotation!



SAFETY PRECAUTIONS

General Safety Precautions

- Read the Operating Instructions of this product carefully prior to use.
- Strictly follow the instructions. The user must fully understand and strictly observe the instructions. Use the product only for the purposes specified in the intended use section of this document.
- Do not dispose the operating instructions. Ensure that they are retained and appropriately used by the product user.
- Only trained and competent personnel are permitted to use this product.
- Comply with all local and national rules and regulations associated with this product.
- Only trained and competent personnel are permitted to inspect, repair and service the product.
- Only authentic L&W parts and accessories may be used for maintenance work. Otherwise, the proper functioning of the product may be impaired.
- Do not use faulty or incomplete products. Do not modify the product.
- Inform L&W in the event of any product or component fault or failure.
- The quality of the air supply must meet EN 12021 specifications for breathing air.
- Do not use the product in areas prone to explosion or in the presence of flammable gases. The product is not designed for these applications. An explosion might be the result if certain conditions apply.

A



SAFETY PRECAUTIONS

Unit customised safety notices

Organisational measures

- In addition to the instruction manual, observe and comply with universally valid legal and other obligatory regulations regarding accident prevention and environment protection.
- In addition to the instruction manual, provide supplementary instructions for supervision and monitoring duties taking into consideration exceptional factors e.g. with regard to organisation of work, production, personnel employed.
- Supervise personnel's work in accordance with the instruction manual, taking into account safety and danger factors.
- Observe all safety and danger notices on the compressor and check readability and completeness.

Safety instructions operation

- Take measures to ensure that the machine is only taken into operation under safe and functional conditions. Only operate the compressor if all protective and safety equipment, e.g. detachable protective equipment, are provided and in good working order.
- Check the compressor at least once per day for obvious damage and defects. Inform the responsible department / person immediately if anything is not as it should be (including operation performance). Shut down the machine immediately if necessary and lock it.
- In case of malfunction, stop the compressor immediately and lock it. Repair malfunctions immediately.
- If there is a failure in the electric energy supply, shut the machine / unit down immediately.
- Ensure safe and environmentally friendly disposal of consumables and old parts.
- The stipulated hearing protectors must be worn.
- Soundproofing equipment on the compressor has to be activated in safety function during operation.
- When handling with fats, oils and other chemical agents, observe the note for the product-related safety.

A



SAFETY PRECAUTIONS

Maintenance instructions

- Hoses have to be checked by the operator (pressure and visual inspection) at reasonable intervals, even if no safety-related defects have been detected.
- Immediately repair any damage. Escaping compressed air can cause injury.
- Depressurise system and pressure lines before beginning repair work.
- Pressurised air lines must be laid and mounted by qualified personnel. Connections must not be mixed up. Fittings, length and quality of the piping must correspond to requirements.
- Adjustment, maintenance and inspection activities and keep appointments, including information on replacement parts / equipment, prescribed in the operating instructions have to be respected.
- If the machine / equipment is completely off during maintenance and repair work, it must be protected against unexpected restart. Turn off main control device and remove the key and/or display a warning sign on the main switch.
- The machine and especially the connections and fittings should be cleaned from oil, fuel and maintenance products at the beginning of the maintenance / repair. Do not use aggressive cleaning agents. Use fibre-free cleaning cloths.
- Switch off compressor and clean with a slightly damp cloth. Remove dirt from cooling pipes by using a brush.
- After cleaning, examine all pipes for leaks, loose connections, chafing and damage. Immediately eliminate any faults.
- Always retighten any screw connections loosened for maintenance or repair work.
- If it is necessary to remove safety devices for maintenance and repair work, these must be replaced and checked immediately after completion of the maintenance or repair work.
- The electrical equipment of the compressor must be regularly checked. Defects, such as loose screw connections or burnt wires, must be immediately rectified by electrically skilled personnel.
- Only personnel with particular knowledge and experience with pneumatics may carry out work on pneumatic equipment.
- Only personnel with particular knowledge and experience in gas equipment may carry out work on gas equipment.

A



SAFETY PRECAUTIONS

Transportation instructions

- Parts which need to be dismantled for transport purposes must be carefully replaced and secured before taking into operation.
- The transport may only be carried out by trained personnel.
- For transportation, only use lifting devices and equipment with sufficient lifting power.
- Do not stand or work under suspended loads.
- Also separate from minor relocation machinery / system of any external energy supply. Before recommissioning, reconnect the machine to the mains according to regulations.
- When recommissioning, proceed according to the operating instructions..

Safety regulations

- Inspections according to legal and local obligatory regulations regarding accident prevention are carried out by the manufacturer or by authorised expert personnel. No guarantees whatsoever are valid for damage caused or favoured by the non-consideration of these directions for use.

A



A

INSTALLATION

INSTALLATION

Installation in closed rooms



Danger

No operation in explosion-hazard areas.

The unit is not approved for operation in areas prone to explosion.

For installation in closed rooms, observe the following:

- Install the unit horizontally and level. The floor must be vibration-free and capable of taking the load of the system weight.
- The compressor room must be clean, dry, dust free and as cool as possible. Avoid direct exposure to sunlight. If possible, install unit in such a manner that the compressor fan can intake fresh air from outside. Ensure adequate ventilation and exhaust air opening.
- When locating the compressor in rooms of less than 30 m³ space where natural ventilation is not ensured or other systems having high radiation are operating in the same room, measures must be taken to provide artificial ventilation.
- Intake air must be free from noxious gas e.g. smoke, solvent vapours, exhaust fumes etc.
- Observe the specified operating temperature (see "Technical Data")!

A

INSTALLATION

Dimensions

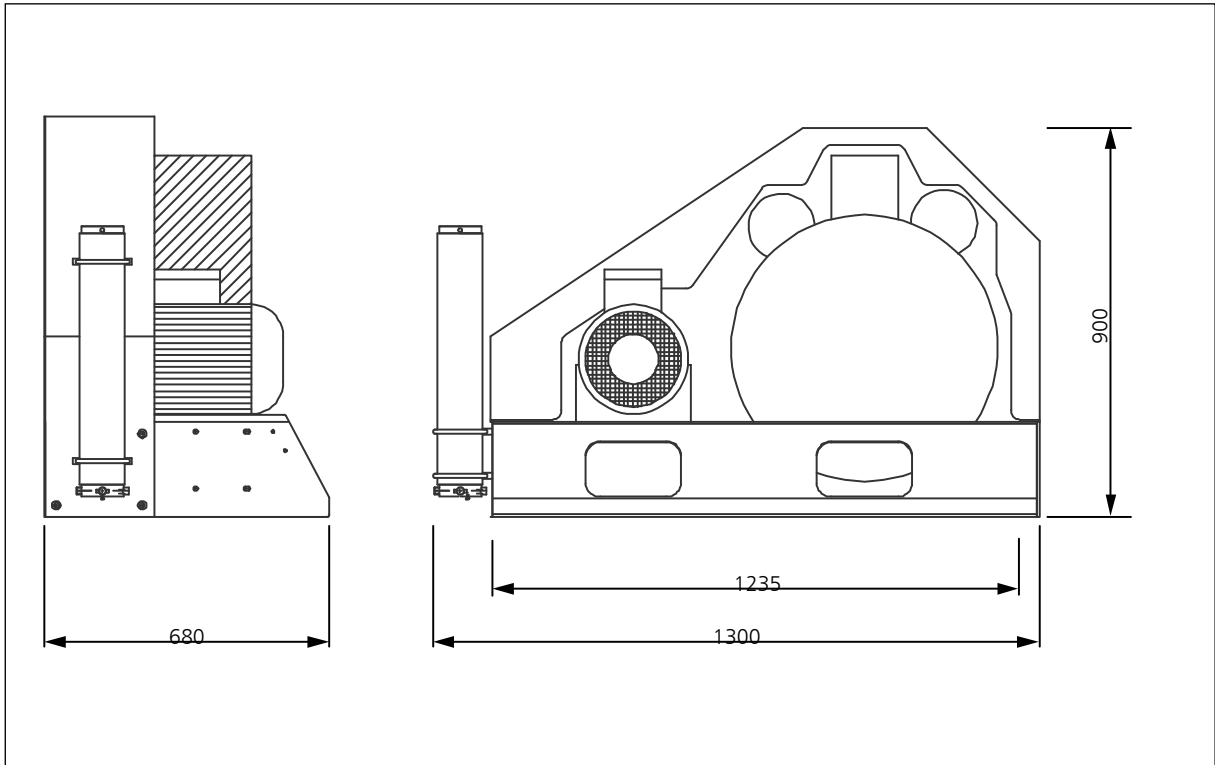

Fig. Dimensions

A

INSTALLATION

Minimum distances



Note

Minimum distances must be adhered!

- Make sure that the compressor always has a sufficient amount of fresh air available.
- To prevent serious damage, ensure that the cooling air flow can flow freely.
- The following minimum distances must be adhered:
Front side min. 1500 mm, sides min. 500 mm, rear side min. 500 mm.
Avoid anything in this area which can restrict the cooling air flow.

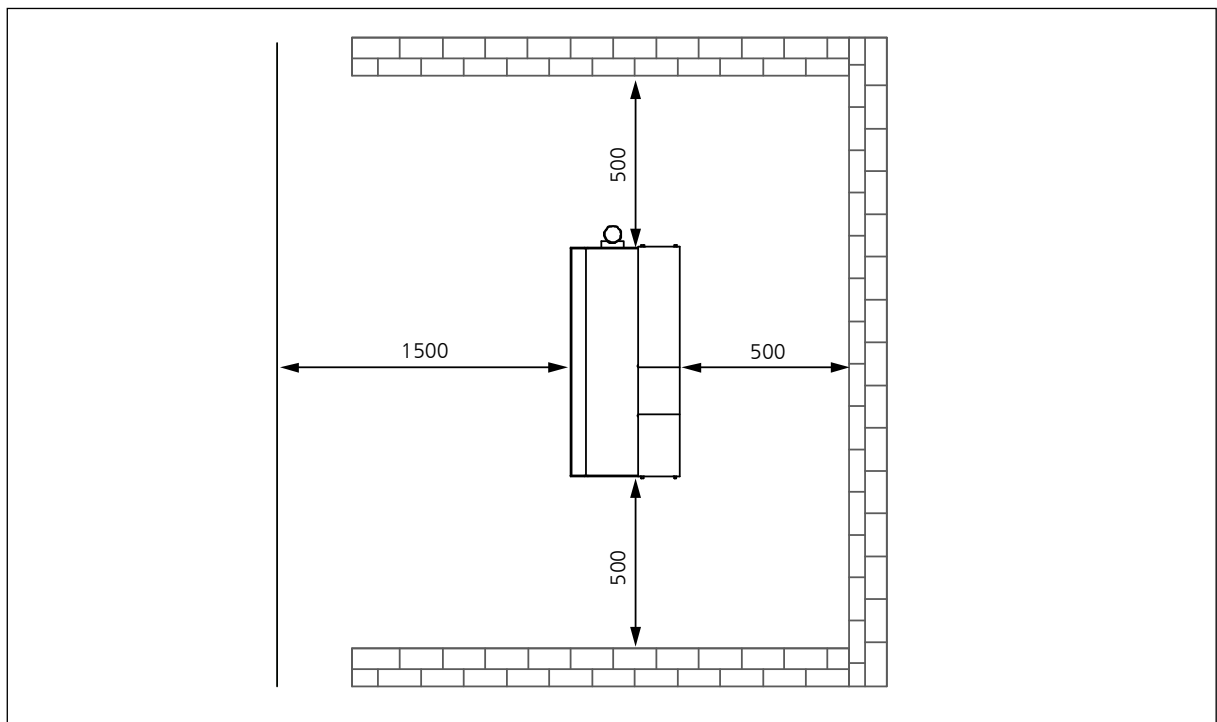

Fig. Minimum distances

INSTALLATION

Ventilation

- Make sure that the compressor always has a sufficient amount of fresh air available for cooling.
- To prevent serious damage, ensure that the cooling air flow can flow freely.
- The necessary cooling air flow can be calculated by using the following formula:
 $300 \times \text{drive power [kW]} = \text{required cooling air flow [m}^3/\text{h]}$
 Example 11kW motor: $300 \times 11\text{kW} = 3300 \text{ m}^3/\text{h} = \text{required cooling air flow.}$
- The fan capacity for fresh air and warm air must meet at least the required cooling air flow.
 The fans must have the same capacity.

A

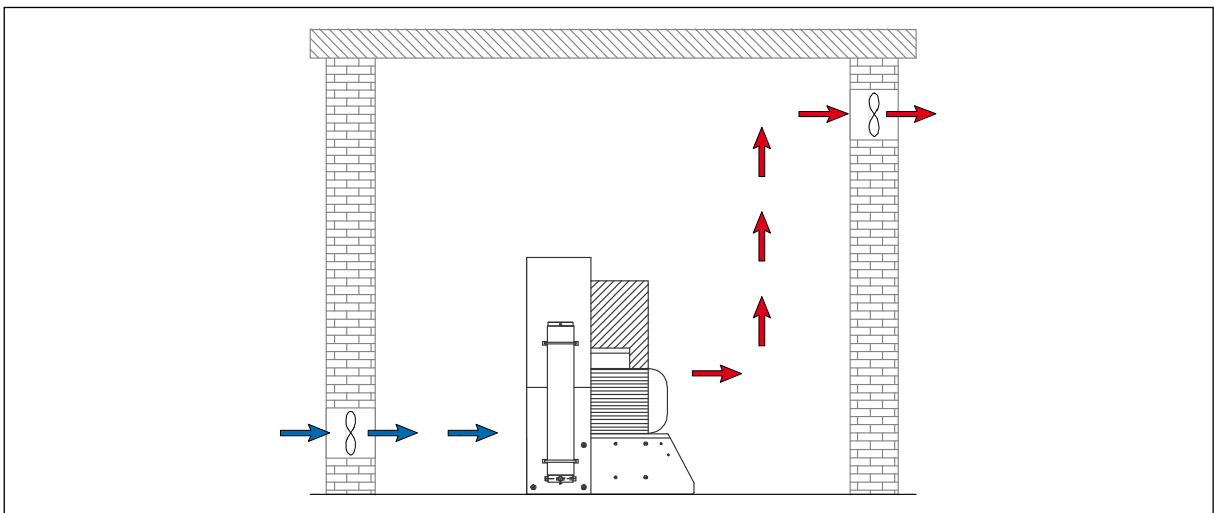

Fig. Ventilation through facade

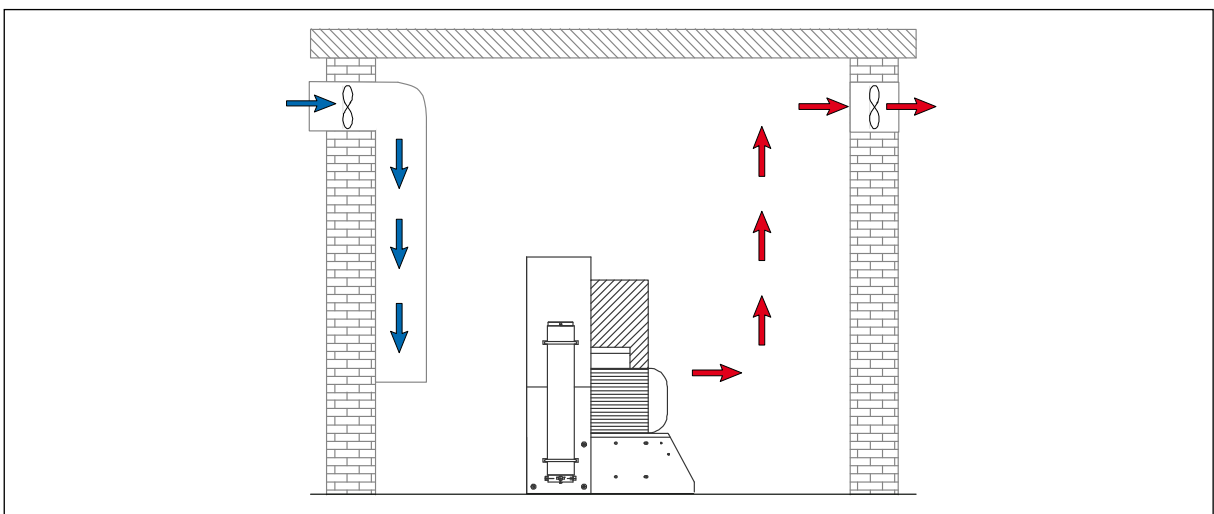

Fig. Ventilation via ventilation stack

INSTALLATION

Electrical Installation



Warning

Work on the electrical equipment on / with the machine / unit may only be carried out by qualified electricians.

For installation of electrical equipment, observe the following:

- If control devices are delivered by the factory, refer to the appropriate wiring diagram.
- Ensure correct installation of protective conductors.
- Check conformity of motor and control device tension and frequency with those of the electric network (see name plate on the compressor).
- The fusing should be done in accordance with the valid regulations of the responsible electricity supply company.
- When connecting the unit to the electrical supply, check the compressor direction of rotation (see chapter "Maintenance" -> Check turning direction).
- Fuse the motor correctly (see table; use slow-blow fuses).

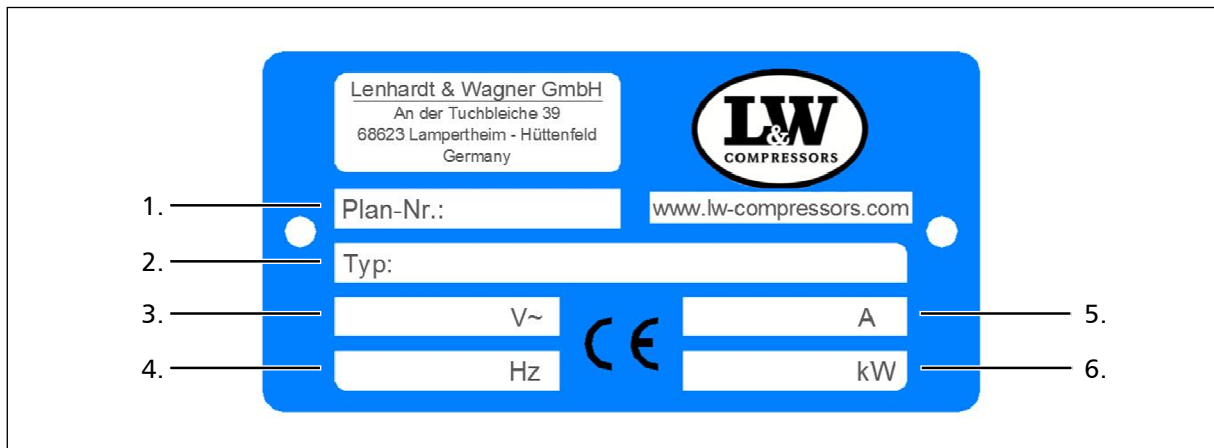

Fig. Compressor name plate

No.	Designation
1.	Circuit diagram number
2.	Compressor type
3.	Power supply
4.	Frequency
5.	Motor current consumption
6.	Nominal motor power

INSTALLATION

Electrical Installation

The standard compressor version is prepared for the connection to three phases (brown, black, grey), neutral conductor (blue) and protective earth conductor (green/yellow).

Fig. - Connection to the switch box

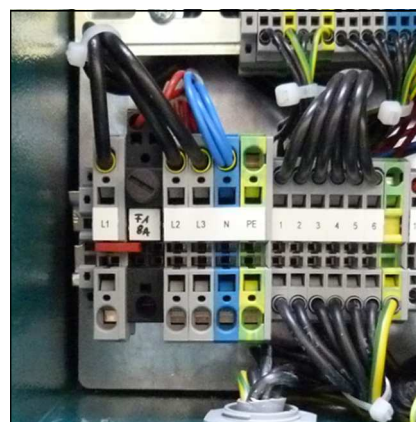

A

Recommended fuses for 360 - 500 V operating voltage

Nominal motor power		Fusing start A		Connection in mm ²	
[kw]	[A]	Direct	Star/Delta	Contactor supply	Motor S/D
2.2	5	10	-	1.5	1.5
4	8.5	20	-	2.5	1.5
5.5	11.3	25	20	2.5	1.5
7.5	15.2	30	25	2.5	1.5
11	21.7	-	35	4	2.5
15	29.9	-	35	6	4
18.5	36	-	50	6	4
22	41	-	50	10	4
30	55	-	63	10	6

Recommended fuses for 220 - 240 V operating voltage

Nominal motor power		Fusing start A		Connection in mm ²	
[kw]	[A]	Direct	Star/Delta	Contactor supply	Motor S/D
2.2	8.7	20	-	1.5	1.5
4	14.8	25	-	2.5	1.5
5.5	19.6	35	25	4	2.5
7.5	26.4	50	35	6	4
11	38	-	50	6	4
15	51	-	63	10	4
18.5	63	-	80	16	6
22	71	-	80	16	6
30	96	-	125	25	10



A

OPERATION



OPERATION

Important operation instructions



Note

Ensure that all persons handling the compressor are familiar with function and operation of the unit.



Wear hearing protection

When working on a running machine, always wear hearing protection.

A

FIRST COMMISSIONING

A

Prior to first commissioning, observe the following:

Necessary steps are described on the next page.

- Ensure that cooling air can flow freely.
- Check compressor oil level by the oil sight glass (see next page).
- Check all connections and retighten if necessary.
- Check if the filter cartridge is in place (see "Service and Maintenance").
- Check the V-belt tension (see next page).
- Check if all filling valves are closed. Open one filling valve and hold tight manually!

Start the compressor

1. Start the compressor by pushing the ON button.
2. Check turning direction - see the rotary direction arrow on the housing of the electric motor (see next pages). If the turning direction is wrong, immediately stop the compressor by pushing the OFF button and contact an authorised electrician.



Warning

Wrong impeller rotation direction!

Immediately after switching the compressor on, check the rotation direction. Depending on the place of installation, the phase sequence can influence the rotation direction.

3. Check oil pressure (if oil pressure gauge is installed).
4. Run the compressor for about 2 minutes.
5. Close the open filling valve carefully.
6. Run the compressor up to maximum pressure and check if the safety valve opens at the adjusted set pressure. (The set pressure value is engraved on the knurled screw of the safety valve.) If this function can not be ensured, the unit must be immediately taken out of service. -> Change safety valve!
7. Stop the compressor by pushing the OFF button.
8. Check the compressor unit for leaks (little smoke emission and release noises from the inlet filter housing can be ignored).
9. Now check the condensate drain valves:
 - Fix the black condensate hoses
 - Open manual condensate drain valves
 - If correct, air escapes
10. Open all filling valves carefully to vent.

FIRST COMMISSIONING

Check oil level



Warning

Check oil level daily. Never start the compressor with a too low oil level. Risk of accidental loss, destruction or deterioration.

Check oil before each operation of the system!

The oil level should be between the middle and upper end of the oil sight glass. Never start the compressor with a too low oil level.

Refill new compressor oil at least when the oil level reached the middle of the indicated area.

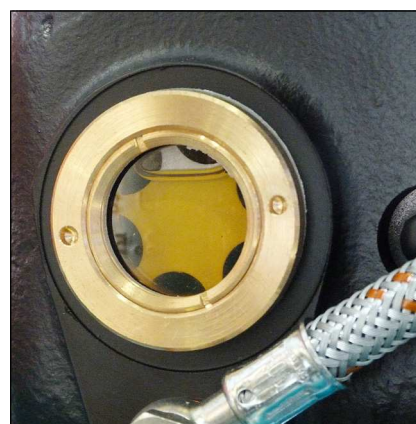

Oil sight glass

Check V-belt tension

The V-belts could lose tension during transportation. Please check the V-belt tension before starting the compressor.

Tension V-belts

To tighten V-belt tension, loosen 4 mounting nuts of the drive motor. Use the tensioning screw to move the electric motor until the V-belt tension is sufficient. Then, tighten mounting nuts and check V-belt tension.

We recommend using a V-belt tension gauge.

Correct V-belt tension

Do not tension V-belts too tight. This damages bearings of compressor and motor. The V-belts should only be tensioned until there is no noise caused by slipping during start.

Settings

Motor Type	Initial Installation	Operation after running in
Electric motors 50Hz	500 N	400 N
Electric motors 60Hz	400 N	300 N

FIRST COMMISSIONING

Check turning direction



Warning

Wrong impeller rotation direction!

Immediately after switching the compressor on, check rotation direction. Depending on the place of installation, the phase sequence can influence the rotation direction.

Before starting the compressor for the first time, check rotation direction (see the rotary direction arrow on the housing of the electric motor).

If the direction of rotation is wrong, the guide pistons can not be sufficiently lubricated, with the consequence that the pistons will be damaged. Furthermore, cooling air flow will not be sufficient.



Rotation direction arrow

A



DAILY COMMISSIONING

Prior to daily operation observe the following:

- Ensure cooling air can flow freely.
- Check compressor oil level by the oil sight glass.
- Check if filter cartridge is in place / observe filter cartridge life!
- Ensure toxic-free, pure intake air.

A

OPERATION

Filling procedure

**Caution! Fill only cylinders which:**

- are marked with the test mark and the test stamp of the expert.
- have been hydrostatic tested (check last test date).
- are rated for the final pressure.
- are free from humidity.

**Note**

The unit must be stopped manually when final pressure is reached. No serial auto shut down. The unit must also be started manually.

**Caution**

Vent condensate drain valves every 15-30 minutes manually.

1. Close all filling valves.
2. Connect the closed compressed air cylinders.
3. Open cylinder valves.
4. Start the compressor by pushing the ON button.
5. When filling pressure gauge increases, open filling valves slowly.
6. Fill the compressed air cylinders to the desired pressure; subsequently close the filling valves slowly.
7. Switch off the compressor.
8. Close and vent all filling valves.
9. Disconnect all compressed air cylinders from filling valves.
10. Open condensate drain valves manually.



OPERATION

Switch off the compressor

The compressor unit is not equipped as standard with an auto shut down. The unit must always be stopped manually when final pressure is reached.

During filling process, the system can be shut down at any time by pushing the red button (OFF) or the emergency stop (only in case of emergency!).



Note

After switching off, open condensate drain valves manually to vent the unit.

A



A

REMEDYING FAULTS

REMEDYING FAULTS

A

Final pressure can not be reached

Cause of fault	Remedy
Connections leaky	Retighten or clean/replace if necessary
Final pressure safety valve leaky	Replace
Pipes / heat exchanger broken	Replace
Condensate drain valves leaky	Unscrew valves, check sealing surfaces, clean, replace if necessary
Final pressure switch stop unit	Verify settings, replace if necessary
Piston of pneumatic condensate valve sticks	Clean pneumatic condensate valve and restore function, check/replace o-rings, replace valve completely if necessary

Strong compressor vibration

Cause of fault	Remedy
V-belt tension too loose	Tension V-belt
Drive motor / Compressor unit loosely	Retighten mounting screws
Anti vibration mounts used up	Replace
Ground not levelled	Ensure a solid and level ground

Air supply too low

Cause of fault	Remedy
Inlet and outlet valves contaminated / defective	Clean, replace if necessary
Cylinder(s), piston(s) or piston ring(s) used up	Replace
V-belt slips	Tension V-belt
See chapter "Final pressure can not be reached"	See chapter "Final pressure can not be reached"

REMEDYING FAULTS

Compressor overheated

Cause of fault	Remedy
Inlet filter cartridge contaminated	Replace
Ambient temperature too high	Improve room ventilation / Reduce operation times
Cooling air inlet and outlet insufficient	Observe minimum distances (see Installation Instructions)
Air intake hose too long	Reduce length of the air intake hose
Air intake hose diameter too small	Use a larger diameter
Wrong compressor rotation direction	Ensure correct phase rotation, observe rotation direction arrow!
Inlet and outlet valves contaminated / defective	Clean, replace if necessary

Safety valve leaks

Cause of fault	Remedy
Inlet and outlet valves of the following pressure stage defective	Clean, replace if necessary
Sinter filter of the following water separator blocked	Replace
Safety valve leaky	Replace

Oil taste in the air

Cause of fault	Remedy
Mole carbon filter cartridge saturated	Replace
Compressor oil unsuitable	Use prescribed oil quality
Filter cartridge unsuitable	Use prescribed filter type
Cylinder(s), piston(s) or piston ring(s) defective	Replace

REMEDYING FAULTS

Automatic condensate drain defective

Cause of fault	Remedy
Solenoid coils defective	Replace
Cable / supply cable defective	Repair, replace if necessary
Timer / relais defective	Replace
Sinter filter of pneumatic condensate valve blocked	Replace
Piston of pneumatic condensate valve sticks	Clean pneumatic condensate valve and restore function, check/replace o-rings, replace valve complete if necessary

Condensate drain starts before reaching final pressure

Cause of fault	Remedy
Pressure stages are not as prescribed, control pressure of pneumatic condensate valve too low	Check corresponding inlet and outlet valve, replace if necessary.
Piston sealing of pneumatic condensate valve contaminated / used up	Clean, replace if necessary
Timer / relais settings not correct	Adjust as prescribed
Timer / relais defective	Replace

Compressor stops before final pressure

Cause of fault	Remedy
Final pressure switch settings not correct	Correct settings
Opening pressure of the pressure maintaining valve too high	Correct settings
Fuse / circuit breaker has tripped Valid only for E models	Check fusing of the power supply / observe regulations
Emergency stop switch has tripped	Unlock emergency stop switch, close compressor housing door correctly



REMEDYING FAULTS

Filter life not sufficient

Cause of fault	Remedy
Pressure maintaining valve settings not correct	Adjust as prescribed
Filter cartridge unsuitable	Replace by a prescribed filter cartridge type
Filter cartridge too old	Observe expiration date
Filter cartridge packaging incorrect / damaged / already opened. Filter cartridge already partly saturated before change	Store filter cartridges properly, dispose defective cartridges
Operating temperature too high	Ensure sufficient ventilation
Cylinder(s), piston(s) or piston ring(s) defective	Replace

Oil consumption too high

Cause of fault	Remedy
Cylinder(s), piston(s) or piston ring(s) defective	Replace
Compressor oil unsuitable	Use prescribed oil quality
Operating temperature too high	Observe prescribed operating temperatures
Oil leak at the compressor block	Tighten corresponding mounting screws, if necessary replace corresponding paper sealing / o-ring / shaft seal



A

MAINTENANCE AND SERVICE

MAINTENANCE AND SERVICE

Service, Repair and Maintenance

Carry out service and maintenance work exclusively when the compressor is stopped and depressurised. The unit should be leak-checked regularly. Leaks can be preferably localised by using a leak detector spray (if necessary, brush pipes with soapy water).

We recommend that only authorised L&W service technicians carry out service work on the bearing of the compressor (crankshaft and connecting rods).

We urgently recommend that all maintenance, repair and installation work must only be carried out by trained personnel. This is necessary because all maintenance work can not be explained exactly and detailed in this manual.

Only use authentic spare parts for service work.



Danger

Components under pressure, such as hose ends, can quickly come loose when manipulated and can cause potentially fatal injuries due to the pressure surge. Any work on system parts may only be performed in a pressure-compensated state.



Warning

The use of accessories that have not been tested can lead to death or serious injury or damage to the unit. Only use authentic spare parts for service work.



Warning

Carry out maintenance or service work when the unit is switched off and protected against unexpected restart.



Warning

Risk of burns!

Carry out maintenance or service work when the unit has cooled down.



MAINTENANCE AND SERVICE

Daily before taking unit into operation

Maintenance work	Type	Quantity	Order No.
Check oil level	-	-	000001
Check condition of all filling hoses	-	-	-
Check filter cartridge lifetime	-	-	-
Operate unit to final pressure and check function of final pressure switch	-	-	-

At 25 operation hours

Maintenance work	Type	Quantity	Order No.
Oil change	-	2,5	000001

Every 3 months or as required

Maintenance work	Type	Quantity	Order No.
Check automatic condensate drain, open manual condensate taps	-	-	-
Check/Retorque all connections and bolts	-	-	-

A



MAINTENANCE AND SERVICE

Annually

Maintenance work	Type	Quantity	Order No.
Oil change, if less than 1000 operating hours	-	2.5	000001
Check opening pressure of final safety valve	-	-	-
Clean coolers	-	-	-
Clean all oil/water separators, if less than 500 operating hours	-	-	-
Service intake filter (depends on condition - if less than 500 operating hours)	-	-	-
Check all connections for leakage	-	-	-

Every 500 operating hours

Maintenance work	Type	Quantity	Order No.
Change intake filter	-	1	000170
Check pressure maintaining/non-return valve	-	-	-
Check V-belt tension and condition	-	-	-



MAINTENANCE AND SERVICE

Every 1000 operating hours

A

Maintenance work	Type	Quantity	Order No.
Replace V-belt	LW 570 E (50Hz)	2	001413
	LW 570 E (60Hz)	2	002878
	LW 570 ES (50Hz)	2	001452
	LW 570 ES (60Hz)	2	002559
Replace sintered metal filter element of water separators	1 / 2 / 3 stage	3	000173
Replace o-rings of water separators	1 / 2 / 3 stage	9	001272
Replace o-ring of oil separator	-	1	001294
Replace silencer	-	1	000178
Replace sintered metal filter of oil separators	-	1	000184
Replace sintered metal filter of pneumatic condensate valve	-	1	000188
Replace oil sieve / oil pump cover gasket	-	1	002569
Oil change	-	2.5	000001
Replace o-rings of the final filter housing	-	2	001287
Replace back-up rings of the final filter housing	-	2	001285

MAINTENANCE AND SERVICE

Every 2000 operating hours

Maintenance work	Type	Quantity	Order No.
Replace all inlet and outlet valves incl. gaskets	1st stage	1	000369
	2nd stage	1	000256
	3rd stage	1	000544
	4th stage	1	000545
	Upper gasket 1st	1	000349
	Upper gasket 2nd	1	000254
	Lower gasket 1st	1	000350
	Lower gasket 2nd	1	003492

Every 4000 operating hours (Latest in 10 years)

Maintenance work	Type	Quantity	Order No.
Replace all o-rings and gaskets of 1st, 2nd, 3rd and 4th stage	gasket	4	000240
	o-ring	2	001274
Replace shaft sea	-	1	000244
Replace oil intake hose	-	1	003109
Replace needle bearings for conrod 2nd, 3rd and 4th stage	-	3	003281
CU-Ring (Ø10 x 16 x 2mm)	-	1	001323
CU-Ring (Ø10,4 X 13,4 X 1mm)	-	1	001324
CU-Ring (Ø13,5 x 18 x 1,5mm)	-	1	001327
CU-Ring (Ø14,5 X 20 X 1,5mm)	-	1	001329

MAINTENANCE AND SERVICE

Service Kits

The service kits contain parts for maintenance according to the factory requirements.

The use of the service kits ensures that all required parts are ordered and replaced and gives assurance that all parts are included in the order. Depending on the model and interval, the service kits include parts such as O-Rings, Sinter Filter, Inlet Filter, V-Belts, Silencers, In-&Outlet Valve, Valve Seals and Compressor oil.



Service Kits

A

Service Kits LW 570 E Compact for 50 Hz

Compressor	Frequency	Operating Hours	Order No.
LW 570 E Compact	50 Hz	1000 h	005166
LW 570 E Compact	50 Hz	2000 h	002272
LW 570 E Compact	50 Hz	4000 h	004029

Service Kits LW 570 E Compact for 60 Hz

Compressor	Frequency	Operating Hours	Order No.
LW 570 E Compact	60 Hz	1000 h	006825
LW 570 E Compact	60 Hz	2000 h	006736
LW 570 E Compact	60 Hz	4000 h	006737



MAINTENANCE AND SERVICE

Check V-belt tension

The V-belts could lose tension during transportation. Please check the V-belt tension before starting the compressor.

A

Tension V-belts

To tighten V-belt tension, loosen 4 mounting nuts of the drive motor. Use the tensioning screw to move the electric motor until the V-belt tension is sufficient. Then, tighten mounting nuts and check V-belt tension.

We recommend using a V-belt tension gauge.

Correct V-belt tension

Do not tension V-belts too tight. This damages bearings of compressor and motor. The V-belts should only be tensioned until there is no noise caused by slipping during start.

Settings

Motor Type	Initial Installation	Operation after running in
Electric motors 50Hz	500 N	400 N
Electric motors 60Hz	400 N	300 N

MAINTENANCE AND SERVICE

Compressor lubrication

Crankshaft bearings of the 1st and 2nd stage get lubrication by an oil slinger. In addition, 1st and 2nd stage are lubricated by spray oil. The guide cylinder of the 3rd stage is lubricated by a mechanical oil pump.

A

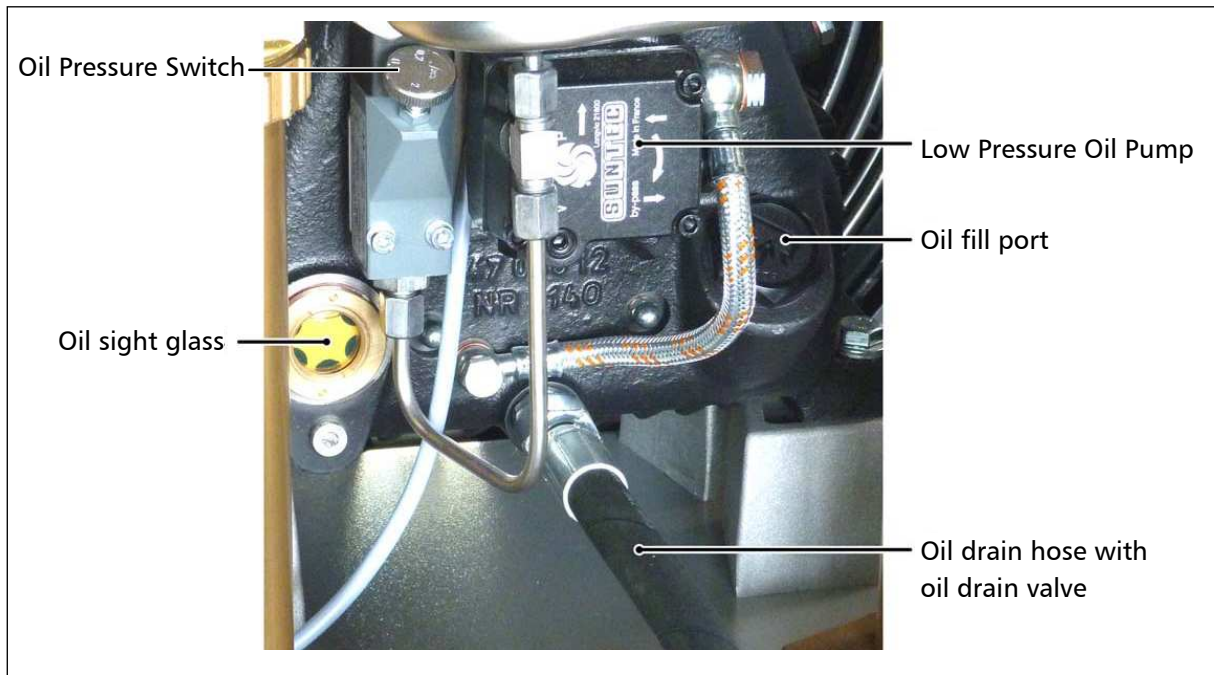

Lubricating System

Check oil level



Warning

Check oil level daily. Never start the compressor with a too low oil level. Risk of accidental loss, destruction or deterioration.

Check oil before each operation of the system!

The oil level should be between the middle and upper end of the oil sight glass. Never start the compressor with a too low oil level.

Refill new compressor oil at least when the oil level reached the middle of the indicated area.

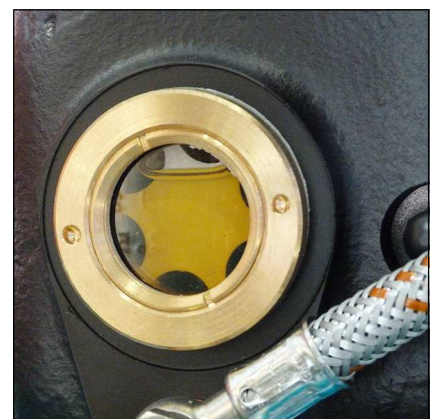

Oil sight glass

Oil change



Note

We recommend oil change at least once a year - depending on total operating hours.

A

Oil change as follows:

- Run compressor warm for approx. 2 min.
- Switch off and vent compressor.
- Place a suitable oil drain tray under the drain hose.
- Open carefully oil drain valve and drain oil completely.
- Close oil drain valve.
- Loosen oil fill port with an appropriate adjustable wrench (AF 0-40 mm) and unscrew manually.
- Fill oil by using a funnel.
- Check oil level. The oil level should be between the middle and upper end of the oil sight glass.
- Screw oil fill port manually in and tighten with the adjustable wrench.

The oil change is now completed.

Maintenance intervals

- First oil change after 25 operating hours (total hours).
- All further changes after each 1,000 operating hours.

Oil and oil capacity

Approx. 2,500 ml synthetic compressor oil is necessary for one oil change. Only use synthetic compressor oil which is recommended as suitable from L&W.

MAINTENANCE AND SERVICE

A

Oil sieve change

Oil sieve change as follows:

- Loosen cover screws (4 pcs).
- Remove the cover, the cover gasket and the oil sieve.
- Clean the oil sieve with petroleum-ether or replace the defective oil sieve.
- Replace the gaskets.
- Soak the gaskets with oil before placing (respect mounting direction).
- Be sure to position the arrow (see Fig., Pos. 1) from the new oil sieve opposite to inlet and return ports of the pump (see Fig., Pos. 2).
- Remount the cover with the 4 cover screws. Tightening torque: 4.5 - 8 N.

The oil sieve change is now completed.

Maintenance intervals

- We recommend cleaning or replacing the oil sieve every 1,000 working hours.
- Service Kit oil pump (002569). Consists of: 000798—Oil sieve + 000672—oil pump cover gasket

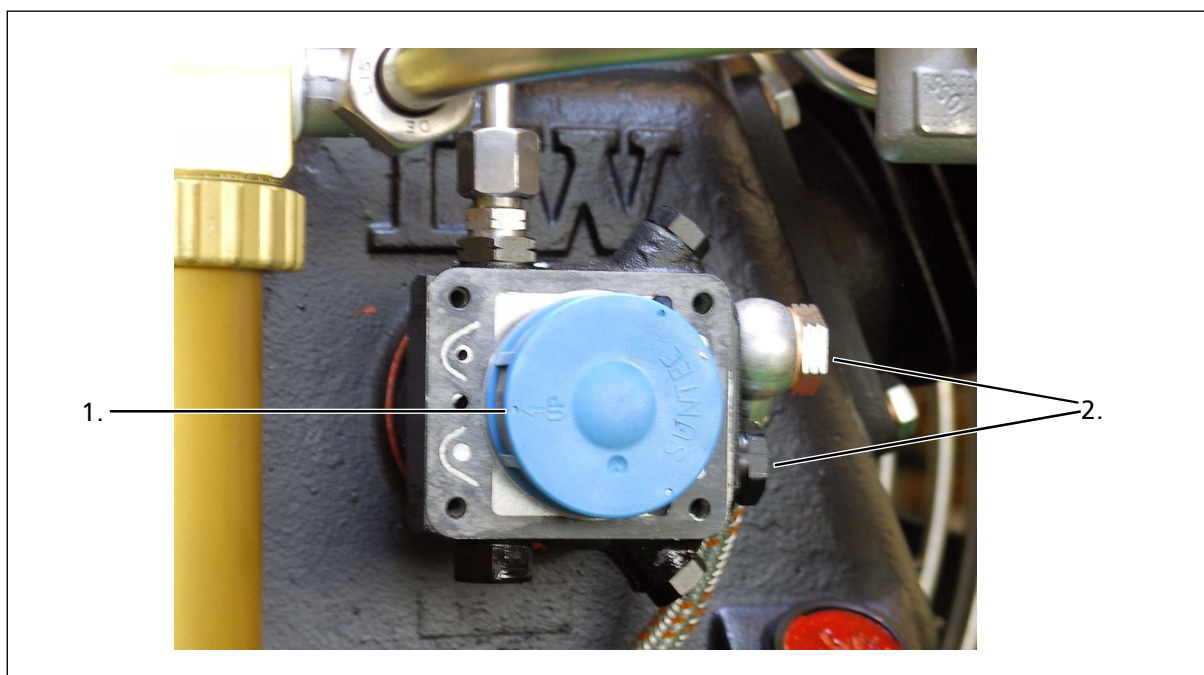

Correct oil sieve mounting direction

MAINTENANCE AND SERVICE

Manual condensation dump system



Note

The collected condensate can contain oil and has to be disposed according to regulations.

Oil- / water separators

The LW 570 E Compact comes as standard with an manual condensate drain. Drain condensate separators every 15 minutes.

To release the complete condensate through the black plastic hoses we recommend using a 20 l container at least.

The drain noise can be kept to a minimum by using a silencer.

Manual drain



Warning

Open valve spindle max. 1.5 turns.
The pressure in the housing can shoot out the valve spindles at high speed.

To drain manually, open the condensate drain valves of the 1st, 2nd and 3rd stage of the oil / water separators and the condensate drain valve of the filter housing (Fig. 2).

Open valve spindle max. 1.5 turns anti-clockwise. The condensate will be drained.

Then close valve spindle clockwise.

Maintenance intervals

We recommend to clean oil and water separators every 500 operating hours or at least once a year, to check for corrosion damage and to replace o-rings if necessary.

All oil / water separators have an integrated sinter filter which has to be replaced every 1,000 operating hours.

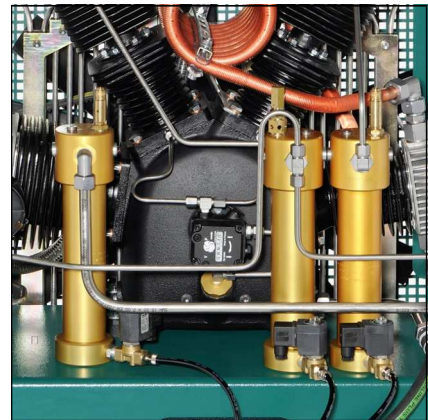

Fig. 1 Oil / water separators 1st, 2nd and 3rd stage with automatic condensate drain system

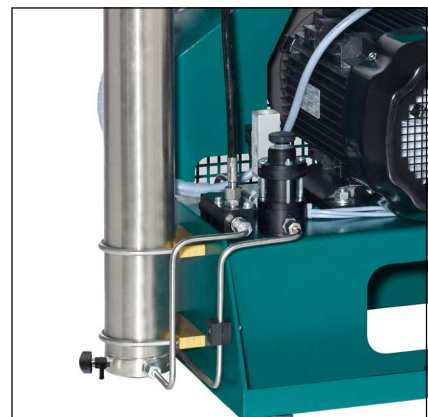

Fig. 2 - Condensate drain valve of the filter housing



Fig. 3 - Condensate drain valve

MAINTENANCE AND SERVICE

Oil / water separators 1st, 2nd and 3rd stage - maintenance



Note

Clean all parts thoroughly before assembly.

Maintenance / cleaning of oil / water separators as follows:

- Loosen pipe connections and mounting screws.
- Remove oil / water separators.
- Unscrew and remove filter top (Fig. 1).
- Open nut and remove separator top (Fig. 2).
- Change sinter filter (Fig. 3).
- Reassemble all parts and tighten nut.
- Change o-ring, previously grease new o-ring (Fig. 4).
- Place separator top and tighten manually.
- Remove bottom part (Fig. 5)
- Change o-ring, previously grease new o-ring
- Press in bottom part
- Mount oil / water separators.
- Tighten pipe connections and mounting screws.

The oil / water separator maintenance is now completed.



Fig. 1 - Unscrew and remove filter top



Fig. 2 - Loosen nut at the separator top

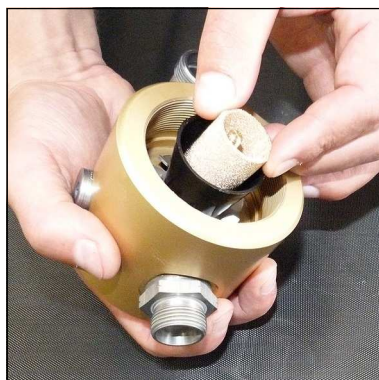

Fig. 3 - Change sinter filter



Fig. 4 - Change o-ring



Fig. 5 - Bottom part

MAINTENANCE AND SERVICE

Filter housing

The mole carbon filter housing is installed on the right hand side of the compressor housing.

Inside the filter housing a jet blows air on to the housing wall. Condensation water and oil are led by centrifugal force to the bottom of the housing. Air flows through the mole carbon filter cartridge, which purifies the air from residual moisture and odours.

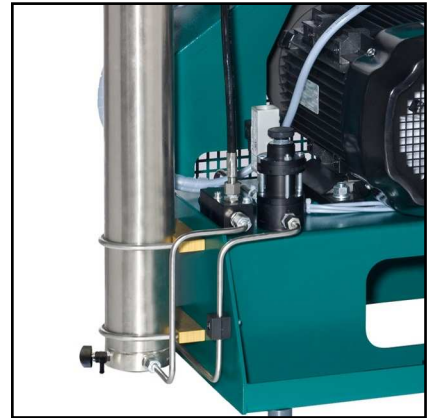

Filter housing

Filter cartridge

The high-pressure compressor is equipped with an integrated breathing air purification system. Air is compressed up to 330 bar, dried and odour- and tasteless purified. Oil residues are bounded. The breathing air filter cartridge consists of a molecular sieve and activated-carbon filter.

Cartridge capacity: approx. 1.7 l

All breathing air filter cartridges are factory vacuum sealed.

We recommend unpacking the filter cartridges just before installation. Filter cartridges which are exposed too long could be saturated with moisture and become unusable.

Maintenance intervals

Filter cartridges should be changed at the following intervals, at +20°C or more often, depending on humidity and ambient temperature:

- 26,3 hours for LW 570 E Compact

MAINTENANCE AND SERVICE

Filter cartridge change

Filter cartridge change as follows:

- Run the compressor up to a pressure of 100 bar.
- Stop compressor.
- Open filling valve.
- Unscrew filter housing cover by using the special filter tool (Fig. 1).
- Place the T-piece end of the filter tool in the recess of the filter cartridge (Fig. 2).
- Unscrew the filter cartridge anti-clockwise and pull the cartridge out of the housing (Fig. 3).
- Open the packing of the new filter cartridge and place it with the filter tool in the filter housing.
- Screw the new filter cartridge hand tight in by using the filter tool.
- Screw the cover of the filter housing first manually in.
- After it has been completely screwed in, turn cover anticlockwise for 90°. This avoids tightening of the cover due to vibration..

The filter cartridge change is now completed.



Note

Ensure that the old filter cartridge is disposed correctly at an approved waste point.



Fig. 1 - Unscrew the filter housing cover.



Fig. 2 - Place the T-piece end of the filter key in the top of the filter cartridge.



Fig. 3 - Pull the cartridge out of the housing.

A

MAINTENANCE AND SERVICE

Filter housing - maintenance



Note

Clean all parts thoroughly before assembly.

Filter housing maintenance as follows:

- Open Filter Cover (Fig. 1).
- Change o-ring and back-up ring, previously grease both (Fig. 2).
- Grease filter cover thread and close.

Dismount filter housing

- Loosen pipe connections and nuts (Fig. 3).
- Remove filter housing.
- Dismount filter housing base.
- Change o-ring and back-up ring, previously grease both (Fig. 4).
- Screw filter base tight in.

Mount filter housing

- Connect pipe connections and tighten.
- Adjust holding clamp and tighten nuts.

The filter housing maintenance is now completed.



Fig. 1 - Open Filter cover



Fig. 2 - Change o-ring and back-up rings

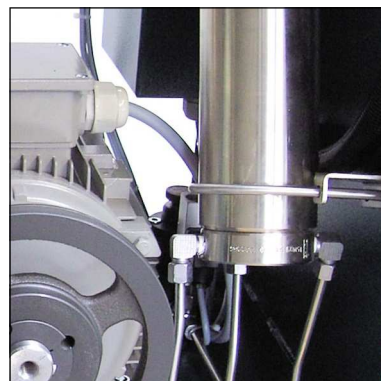

Fig. 3 - Loosen pipe connections and nuts



Fig. 4 - Change o-ring and back-up rings

Inlet filters



Note

Dirty filters make intaking air difficult and reduce delivery capacity. Risk of compressor overheating.

A micro filter cartridge is used as an air inlet filter. Check air inlet filter regularly or replace it. Defective air inlet filters should be immediately replaced with a corresponding filter.

Maintenance intervals

We recommend that the filter cartridge should be replaced every 1,000 working hours (depending on pollution grade).

Inlet filter cartridge change

Inlet filter cartridge change as follows:

- Loosen cover by pushing the three clips apart.
- Remove inlet filter cartridge and replace it by a new one.
- Refit cover and snap the three clips until a loud 'click' can be heard.

The inlet filter cartridge change is now completed.

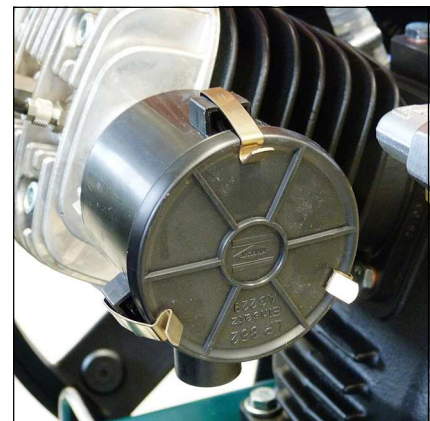

Air filters

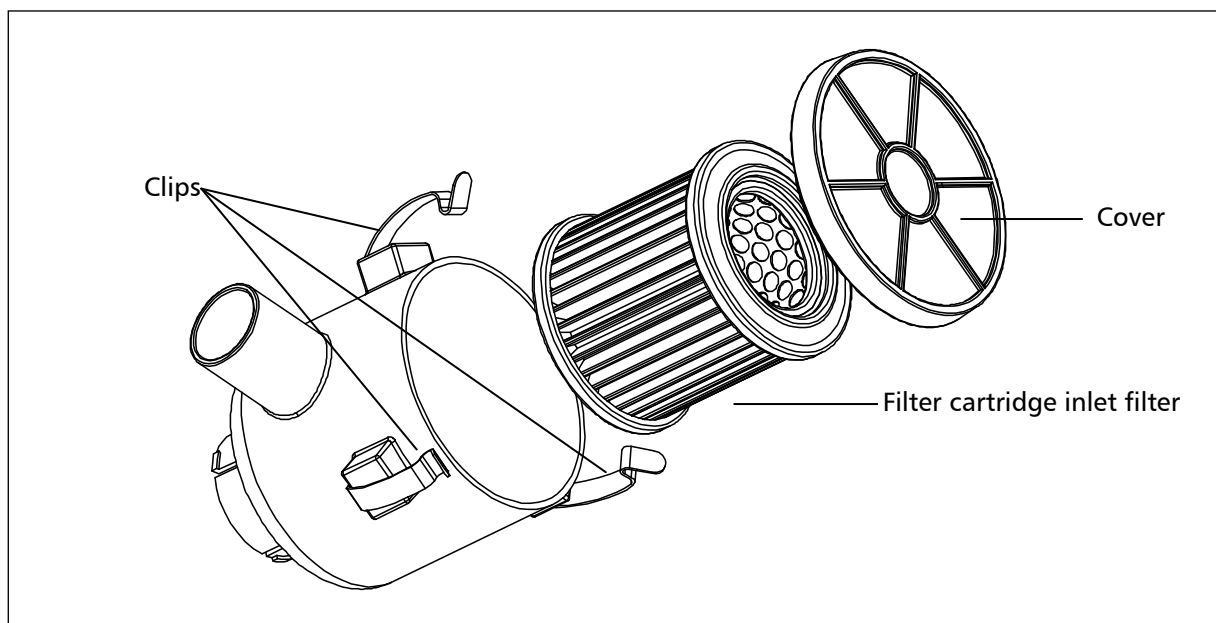

Filter cartridge inlet filter

MAINTENANCE AND SERVICE

Cylinder heads and valves

Inlet and outlet valves of the specific compressor stages are located between valve head and cylinder. Outlet valves open while piston downstroke, inlet valves open while upstroke or compression stroke.

Valves are subject to normal wear and tear and have to be replaced at certain intervals (depending on specific operating conditions). Dismount valve heads to change valves. The three valves are combined inlet and outlet valves. The first and second stage valves are plate valves. The third stage contains a spring operated piston which acts inside a bronze cylinder.



Valve head 3rd stage

Maintenance intervals

All valves should be replaced after 2,000 working hours due to normal wear and tear. To replace valves the cylinder heads have to be removed. There are no special tools required to replace these valves.

Available special tools

Special tools are not necessary for dismounting inlet and outlet valves but make work easier.

Order number: 006847



Special tool

Replace inlet and outlet valves 1st and 2nd stage



Note

The figures of the parts can differ due to the different stages.

Change inlet and outlet valves 1st and 2nd stage as follows:

Remove Inlet / Outlet Valve

- Loosen pipe connections
- Loosen valve head screws (Fig. 1)
- Remove valve head
- Pull out inlet and outlet valve (Fig. 2). CAUTION: Observe that the lower copper valve ring is also pulled out. (It can still stick inside the cylinder)
- Check valve head if defective

Install Inlet / Outlet Valve - see following page

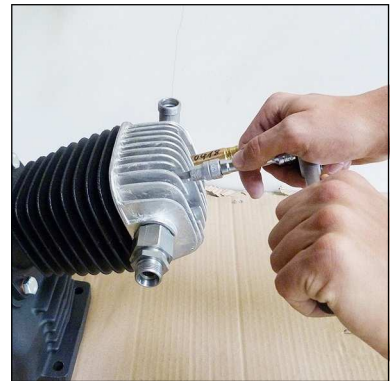

Fig. 1 - Loosen valve head screws



Fig. 2 - Pull out inlet and outlet valve

Replace inlet and outlet valves 1st and 2nd stage - continued from previous page

A



Caution

The exact alignment of upper and lower valve gasket is very important. Inlet and outlet channels have to be exactly centred. Do not turn inlet and outlet valve after insertion. The copper valve ring could cover outlet channels.

Install Inlet / Outlet Valve

- Grease the lower valve gasket slightly and place on the new inlet and outlet valve.
CAUTION: Observe correct copper valve ring position (centre inlet and outlet channels).

- Place the new inlet and outlet valve straightly into the cylinder (Fig. 3).

CAUTION: Do not turn the inlet and outlet valve inside the cylinder! The copper valve ring could cover outlet channels!

- Place the upper valve gasket on the inlet and outlet valve.

CAUTION: Observe the correct paper gasket position (centre inlet and outlet channels). (Fig. 4)

Note: Valve head screws can be inserted into the valve head to secure the upper valve gasket.

- Refit the valve head and tighten the valve head screws cross-wise.

Starting torques:

1. nd Stage 45 Nm
2. nd Stage 30 Nm

The replacement inlet and outlet valves 1st and 2nd stage is now completed.

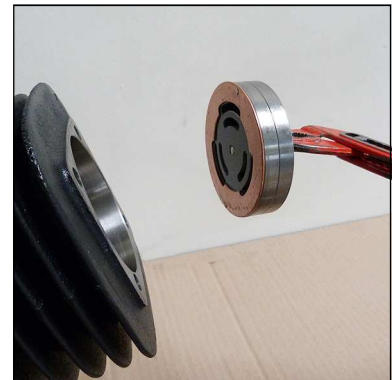

Fig. 3 - Place new inlet and outlet valve straightly into cylinder



Fig. 4 - Ensure the correct mounting position of the paper gasket

Replace inlet and outlet valves 3rd and 4th stage



Note

The figures of the parts can differ due to the different stages.

Replacement inlet and outlet valves as follows:

- Loosen pipe connections
- Loosen valve head screws (Fig. 1)
- Remove lower valve gasket (Fig. 2)
- Dismount inlet and outlet valve (Fig. 3). Observe that the upper valve gasket is also pulled out. (It can still stick inside the cylinder head)
- Check valve head if defective (check centre pin)
- Mount valve gasket on inlet and outlet valve.
CAUTION: Ensure correct mounting position of the upper valve gasket (Fig. 4).
- Insert new inlet and outlet valve into valve head.
CAUTION: Observe correct position between valve centre hole and valve head centre pin.
- Place bottom valve gasket
- Place valve head with the new inlet and outlet valve. Tighten valve head screws crosswise (tightening torque 30 Nm).

Replacement inlet and outlet valves complete.



Fig. 1 - Loosen valve head screws



Fig. 2 - Remove lower valve gasket

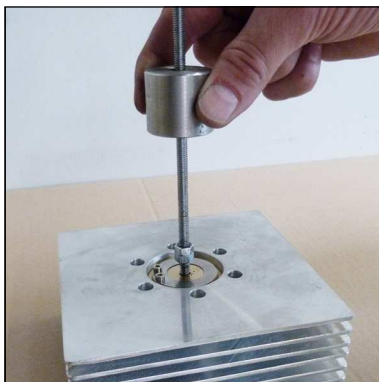

Fig. 3 - Remove inlet and outlet valve



Fig. 4 - Ensure correct mounting position of the upper valve gasket

MAINTENANCE AND SERVICE

Safety valves

Every pressure stage is equipped with a separate over pressure safety valve. Safety Valves avoid a non permissible high pressure at the specific pressure stages and limit maximum operation pressure of the compressor.

Safety valves are adjusted to:

- 1st Stage: 8 bar
- 2nd Stage: 22 bar
- 3rd Stage: 90 bar
- 4th Stage: max. final pressure

The adjusted blow-off pressure [bar] of the safety valves is indicated on their housings.

All safety valves are factory sealed with special L&W safety seals to avoid manipulation of the limit value settings.

Safety valves with removed seals have to be immediately checked for the prescribed settings and replaced if necessary.

The safety valve of the final stage is furthermore equipped with a knurled screw to be activated once.

Turning the knurled screw clockwise could vent the valve completely and therefore the final filter housing.

During normal operation conditions, the knurled screw has to be turned anti-clockwise up to the upper stop. An integrated circlip avoids complete unscrewing.

If a safety valve blows off, it indicates problems with either inlet or outlet valve of the following stage.



Note

Replace defective safety valves immediately!

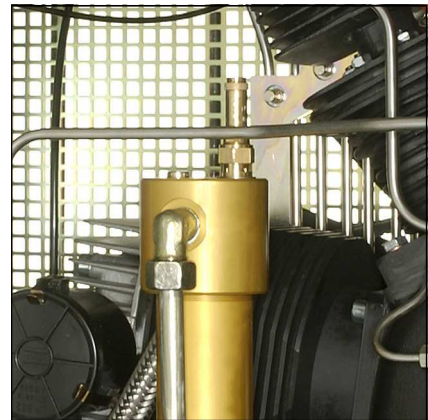

Safety valve 1st stage

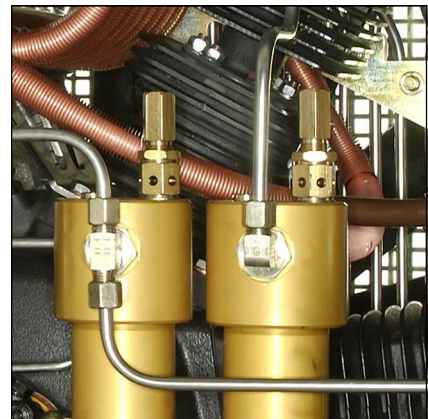

Safety valve 2nd and 3rd stage



Safety valve 4th stage

A

Pressure maintaining / non return valve

**Note**

If the adjusted opening pressure of the pressure maintaining valve is higher than the final pressure of the compressor, the final pressure safety valve blows off before pressure maintaining valve opens (final pressure = 0 bar). When valve settings are not clear (e.g. after disassembly / repair), start the adjustment with a low basic setting (turn adjusting screw approx. 3 times in).

A pressure maintaining / non return valve is installed after the mole carbon filter housing. It maintains a pressure of at least 150 bar inside the filter housing - this optimises filter efficiency.

Pressure maintaining valve

The pressure maintaining valve drains a large part of the water content of the compressed air mechanically by ensuring the minimum outlet pressure. This guarantees optimal drying and purification of the breathing air.

After starting the compressor, the pressure inside the final filter housing constantly increases. The pressure maintaining the valve prevents the compressed air from blowing off (final pressure gauge = 0 bar).

When the adjusted opening pressure is reached (150 and 180 bar), the purified compressed air flows via pressure maintaining and non return valve to the filling valve.

The value of the opening pressure of the pressure maintaining valve can be read at the final pressure gauge. When opening pressure is reached, the pressure gauge value increases within a few seconds.



Pressure maintaining/non-return valve

MAINTENANCE AND SERVICE

Safety valve test



Note

Do not fill any tank during test phase!

Safety valve test as follows:

- Disconnect compressor from the electrical power supply and protect against unexpected restart.
- Remove the cover of the switch box.
- Switch on the "Test Safety Valve" switch (pressure switch will be deactivated!).
- Mount the cover of the switch box.
- Connect the compressor to the electrical power supply.
- Close filling valves.
- Start the compressor.
- Watch the final pressure gauge. The safety valve should open when reaching working pressure of the compressor. If not, switch off the unit and take out of service until the safety valve has been replaced.
- Switch off the compressor.
- Disconnect the compressor from the electrical power supply and protect against unexpected restart.
- Remove the cover of the switch box.
- Switch off the "Test Safety Valve" switch (pressure switch will be activated!).
- Mount the cover of the switch box.
- Connect the compressor to the electrical power supply.

The safety valve test is now completed.

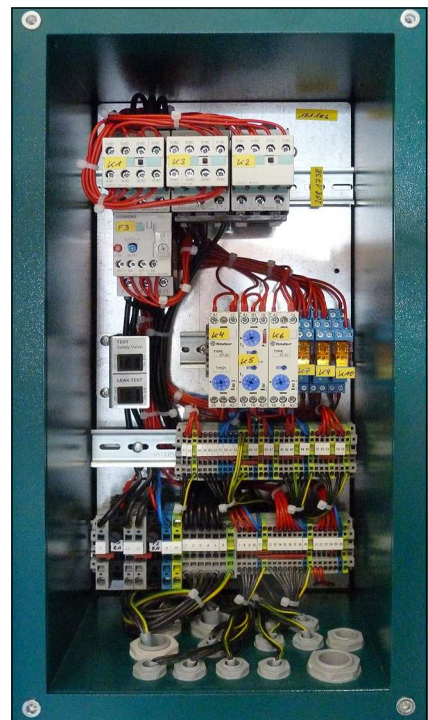

Switch box

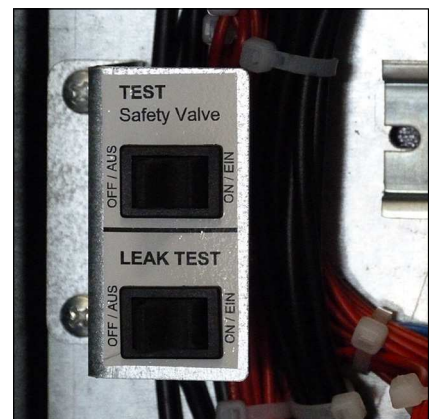

Safety valve test switch (up)

MAINTENANCE AND SERVICE

Leak test



Note

Do not fill any tank during test phase!

Leak test as follows:

- Disconnect the compressor from the electrical power supply and protect against unexpected restart.
- Remove the cover of the switch box.
- Switch on the leak test switch (solenoid valves will be deactivated!).
- Mount the cover of the switch box.
- Connect the compressor to the electrical power supply.
- Close filling valves.
- Start the compressor.
- Switch off the compressor at a pressure of approx. 150 bar.
- Verify the compressor for release noises. (A slight hiss of the air inlet filter nozzle can be ignored). If release noises occur, localise blow off position(s).
- Switch off the compressor.
- Disconnect the compressor from the electrical power supply and protect against unexpected restart.
- Remove the cover of the switch box.
- Switch off the leak test switch (solenoids will be activated!).
- Mount the cover of the switch box.
- Connect the compressor to the electrical power supply.

The leak test is now completed.

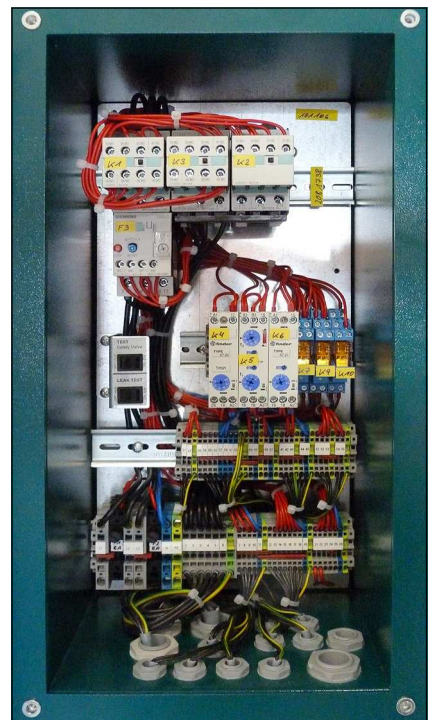

Switch box

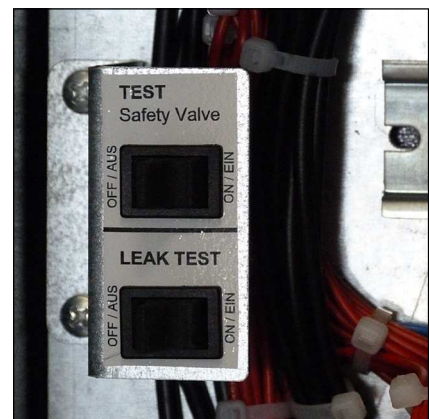

Leak test switch (lower)

MAINTENANCE AND SERVICE

Test of pressure equipment

According to the Pressure Equipment Directive (PED 97/23/EC) and TÜV Darmstadt (German supervising authorities). State: 10th of December, 2005

Subject: pressure equipment with a product permissible operating pressure [bar] x content volume [litres] from 200 up to 1000.

Example: Filter housing 1.7 l

Maximum operating pressure: 350 bar

Content volume: 1.7 litres

$350 \text{ bar} \times 1.7 \text{ litres} = 595$

595 is smaller than 1000 -> result: Test is applicable!!

Example: Filter housing 2.3 l

Maximum operating pressure: 350 bar

Content volume: 2.3 litres

$350 \text{ bar} \times 2.3 \text{ litres} = 805$

805 is smaller than 1000 -> result: Test is applicable!!

Pressure equipment from 200 up to 1000 have to be tested as follows:

1. Examination after 5 years by a qualified person or authorized organisations.

Visual inspection, inside and outside.

2. Examination after 10 years by a qualified person or authorized organisations.

Visual inspection, inside and outside.

In addition, a water pressure test is carried out at 1.5 times of the permissible vessel operating pressure.



A

MAINTENANCE RECORDS



MAINTENANCE RECORDS

Introduction form for the Operator

A

No.	Surname, Name	Date	Place	Signature	Instructor

By adding themselves to this list, the person that signs it confirms having been given a yearly introduction/instruction about the function and operation of the compressor unit. Furthermore, they have be informed about the relevant safety rules and regualtions (TRG, DGRL, BetrSichV, GSG, GSGV).



MAINTENANCE RECORDS

Top up oil, oil change

Date	Operating hours	Oil quantity [l]	Name

A



MAINTENANCE RECORDS

Cartridge change

A

Date	Operating hours	Difference	Name



MAINTENANCE RECORDS

Maintenance work

Description	Date, signature

A



MAINTENANCE RECORDS

Replaced Parts

A

Designation	Part number	Date, signature

STORAGE

Conservation / storage of the compressor

If the compressor unit is not to be used for an extended period of time, we recommend to carry out the following work before storage time:

- Run the compressor at 200 bar filling pressure for approximately ten minutes (control the flow with the filling valve to maintain constant pressure).
- Replace compressor oil, open filling valve(s) and run compressor for a few minutes.
- Stop compressor and open drain valves (depending on the compressor type, this may happen automatically). Remove top cap of final filter housing: clean throat, grease o-ring. and throat with a food grade grease or silicone grease. Close filter housing.
- Remove intake filter cartridge and undo intake pipes on all valve heads.
- Start compressor unit. Spray a few drops of compressor oil into intake connectors.
- Stop compressor unit and insert intake filter cartridge. Bring intake pipes back in position and fix connections and nuts. Close filling- and drain valves.
- Store the compressor in a cool dry place free from dust and contamination. A dust cover is recommended as long as condensation can be avoided.
- If compressor unit should be stored for a period of more than one year, an oil change is strongly recommended before it's been re-used.
- Fuel driven units only: fill up fuel tank to top level to avoid corrosion.

De-conservation, commissioning

After the compressor has been stored, the following steps are to be taken:

- If compressor hasn't been used for longer than 12 months, we strongly recommend an oil change before any use.
- Replace intake filter cartridge and check oil level.
- Clean compressor unit, check for foreign objects. Check condition and tension of V-belts, replace if necessary. Check condition of filling hoses, replace if necessary.
- Secure hoses against whipping and open filling valves and run compressor for approximately 10 minutes.
- Check condition of final filter cartridge, replace if necessary.
- Close filling valves and run compressor up to final pressure.
- Check safety valve relief pressure of final stage and/or pressure switch setting.
- Check all connections and pipe work for leaks.

Once all above steps are completed, compressor unit is now ready for use.

STORAGE

Transportation instructions

- Parts which need to be dismantled for transport purposes must be carefully replaced and secured before taking into operation.
- The transport may only be carried out by trained personnel.
- For transportation, only use lifting devices and equipment with sufficient lifting power.
- Do not stand or work under suspended loads.
- Also separate from minor relocation machinery / system of any external energy supply. Before recommissioning, reconnect the machine to the mains according to regulations.
- When recommissioning, proceed according to the operating instructions..

Disposal

The product must be disposed in accordance with national waste disposal regulations and by an appropriate waste disposal company.

Electric and electronic components

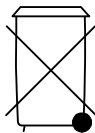

EU-wide regulations for the disposal of electric and electronic appliances which have been defined in the EU Directive 2002/96/EC and in national laws are effective from August 2005 and apply to this device.

Common household appliances can be disposed by using special collecting and recycling facilities. However, as this device has not been registered for household usage, it must not be disposed of through these means.

The device can be returned to L&W. Please do not hesitate to contact us if you have any further questions on this issue.

Operating Instructions

ECC - Electronic compressor control





TABLE OF CONTENTS

General Information

General Information	3
Description of Warning Symbols	3

Description

Specifications / Options	4
Switchboard	5

Operation and Function

Main Menu	6
Selection Menu (M100)	7
Display Menu (M200)	8
Inter-Stage Pressure Display.....	8
Display II (M270)	9
Settings Menu (M300).....	10
Set Stop Pressure - automatic mode (M320).....	11
Set Restart Pressure - automatic mode (M330).....	11
Set Stop Pressure - semi-automatic mode (M340)	11
Test Menu (M400)	12
Test Solenoids (M420)	12
Test safety valve (M430)	13
Test stop without venting (M440)	13
Statistics Menu (M500).....	14
Maintenance Menu (M600)	15
Confirm Maintenance (M680).....	16
Operation Mode (M700).....	17
Language Menu (M750)	17
Adjusting Display Backlight.....	18
Software Update	18
Spare part lists.....	19
Manufacturer in terms of 97/23/EC.....	20

B

GENERAL INFORMATION

General Information

We strongly recommend reading this manual thoroughly prior to operation and follow all the safety precautions precisely. Damage resulting from any deviation from these instructions is excluded from warranty and liability for this product. Carry out other commissioning steps only if you have fully understood the following contents.

Before commissioning and using the unit, carry out all the essential preliminary work and measures concerning legal regulations and safety. These are described on the following pages of this operation manual.

B

Description of marks and warning signs

The following warning signs are used in this document to identify the corresponding warning notes which require particular attention by the user. The warning signs are defined as follows:



Caution

Indicates an imminently hazardous situation which, if not avoided, could result in serious injury, physical injury or death.



Warning

Indicates a potentially hazardous situation which, if not avoided, could result in physical injury or damage to the product or environment.



Note

Indicates additional information on how to use the unit.



DESCRIPTION

Specifications and Options

All L&W compressors can be optionally equipped with the all-electrical computer supported control system "ECC". It is easy to operate and allows multiple and individual settings.

Specifications

- LCD-Display with key pad
- Automatic & semi-automatic operation mode
- Automatic dump system
- Integrated counter for operation hours
- Integrated counter for load cycles
- Maintenance intervals automatically displayed
- Required service part numbers automatically displayed
- Fully adjustable pressure ranges for start and stop
- Warning messages ("Housing Open" / "Emergency Switch")
- Check of end-pressure safety valve possible
- Auto switch-off when system is not running
- Extendable by additional modules (e.g. external filling panel)
- Easy to operate menu
- Door position switch (housing open message)
- Load-free or depressurised start cycles

Options

- Oil pressure control
- Oil temperature control
- Cylinder head temperature control
- Inter stage pressure monitoring
- PIN controlled access
- Master / slave option (if more than one ECC equipped compressors are combined)

DESCRIPTION

Switchboard



No.	Description
1	LCD Display
2	Key Pad
3	LED Display (Compressor OFF)
4	LED Display (Power)
5	LED Display (Compressor ON)



OPERATION AND FUNCTION

Main Menu

Immediately after the compressor has been connected to power, the ECC-display shows the following Main Menu::

Charging	0 min
Total	0,0 h
Start : 1	Stop : 0
Help: *	OFF
Final Press	0 bar

Present filling time in minutes

Total operation hours

Key 1 to start compressor / Key 0 to stop compressor

* Key leads to submenus Current operation state = Off

Present filling pressure

B

The following keys can now be used:

Key	Function / Description
1	Start - Starts the compressor
0	Stop - Stops the compressor
*	Leads to the submenus

After typing the * key the following Selection Menu appears.



OPERATION AND FUNCTION

Selection Menu (M100)

After typing the * key in the Main Menu the following Selection Menu appears.

Selection:		
2	Display	Key 2 leads to submenu "Display"
3	Settings	Key 3 leads to submenu "Settings"
4	Test	Key 4 leads to submenu "Test"
5	Statistics	Key 5 leads to submenu "Statistics"
6	Maintenance	Key 6 leads to submenu "Maintenance"
7	Operation Mode	Key 7 leads to submenu "Operation mode"
(M100)	Return : #	Key # leads back to "Main Menu"

(M100) tells that you are currently on menu page 100.



Note

At any time, the unit can be started with key 1 or shut down with key 0.
Caution: Risk of accident during maintenance work!

B

OPERATION AND FUNCTION

Display Menu (M200)

Pushing key 2 in the Selection Menu leads to Submenu "Display".

Display I:	
2	Press. Stage 1
3	Press. Stage 2
4	Press. Stage 3
5	Cyl. Head Temp.
6	Oil Temp.
7	Display II
(M200)	Return : #

Key 2 shows current pressure of the 1st stage*

Key 3 shows current pressure of the 2nd stage

Key 4 shows current pressure of the 3rd stage

Key 5 shows temperature of the final stage cylinder head

Key 6 shows the oil temperature

Key 7 shows Display II

Key # leads back to "Main Menu"

(M200) tells that you are currently on menu page 200.

By pushing key 2 (inter-stage pressure 1) the following Display appears.

Inter-Stage Pressure Display

Pushing key 2 in the Display Menu leads to the Inter-Stage Pressure 1 Display Menu.

Charging	0 min
Total	0,0 h
Start: 1	Stop: 0
Help:*	OFF
Press.	0 bar
1 st Stage	0,0 bar

Use keys 3 to 6 in the Menu "Display I" to change between the displayed values.



Note

Pushing key 8 in the display menu "Display II" leads to the option "Pressure200/300" for compressors with 2 filling pressures. Displayed in field 3 of the display menu "Display I".



OPERATION AND FUNCTION

Display II (M270)

Pushing key 7 in the Selection Menu leads to Menu "Display II".

Display II:

Press.	Temp.
4: 0	C: 0
5: 0	D: 0
6: 0	E: 0
7: 0	F: 0
bar	°C
(M270)	Return : #

This display shows further customer specific pressure and temperature values.

Key # leads back to "Main Menu"

B

OPERATION AND FUNCTION

Settings Menu (M300)

Pushing key 3 in the Selection Menu leads to the Settings Menu.

Settings:	
Automatic	
2	Stop pressure
3	Restart Press.
Semi-Automatic	
4	Stop Pressure
9	Close
(M300)	Return : #

Key 2 leads to submenu „Set Stop Pressure“

Key 3 leads to submenu „Set Restart Pressure“

Key 4 leads to submenu „Set Stop Pressure“

Key 9 leads back to submenu "Selection"

Key # leads back to "Main Menu"

B

Use menu M700 to change between "Automatic" and "Semi-Automatic" mode.

Restart pressure can only be set in "Automatic Mode".

Prior to setting the pressure, start the safety valve test.



Attention during maintenance

During automatic mode, the compressor can automatically start by itself at any time, depending on the selected restart pressure (see "Set Restart Pressure" M330).



OPERATION AND FUNCTION

Set Stop Pressure - automatic mode (M320)

Only valid in automatic mode, see menu M700.

Set
Stop Pressure:
Actual: 330 bar
7 New Value:
>> XXX bar
4 (050,, 333)
8 Confirm
(M320) Return : #

Current restart pressure
Key 7 if restart pressure should be changed
XXX indicates modified stop pressure
Chooseable pressure range for restart pressure
Key 8 confirms new restart pressure
Key # leads back to "Main Menu"

B

Set Restart Pressure - automatic mode (M330)

Only valid in automatic mode, see menu M700.

Set
Restart Pressure:
Actual: 180 bar
7 New Value:
>> XXX bar
4 (030,, 310)
8 Confirm
(M330) Return : #

Current restart pressure
Key 7 if restart pressure should be changed
XXX indicates modified restart pressure
Chooseable pressure range for restart pressure
Key 8 confirms new restart pressure
Key # leads back to "Main Menu"

Set Stop Pressure - semi-automatic mode (M340)

Only valid in semi-automatic mode, see menu M700.

Set
Stop Pressure:
Actual: 180 bar
7 New Value:
>> XXX bar
4 (030,, 310)
8 Confirm
(M340) Return : #

Current stop pressure
Key 7 if stop pressure should be changed
XXX indicates modified stop pressure
Chooseable pressure range for stop pressure
Key 8 confirms new restart pressure
Key # leads back to "Main Menu"

OPERATION AND FUNCTION

Test Menu (M400)

Pushing key 4 in the Selection Menu leads to the Test Menu.

Test:	
2	Solenoids
3	Safety Valve
4	Test-Stop
9	Close
(M400)	Return : #

Key 2 leads to submenu "Test Solenoids"

Key 3 leads to submenu "Test Safety Valve"

Key 4 leads to submenu "Test Stop without Venting"

Key 9 leads back to submenu "Selection"

Key # leads back to "Main Menu"

B

Test Solenoids (M420)

Pushing key 2 in the Selection Menu leads to Submenu "Test Solenoids".

Test Solenoids	
3	open
7	close
9	Close
(M420)	Return : #

Key 3 opens solenoids

Key 7 closes solenoids

Key 9 leads back to submenu „Test“

Key # leads back to "Main Menu"



Note

This menu can not be left unless solenoids have been closed by key 7.

OPERATION AND FUNCTION

Test safety valve (M430)

Pushing key 3 in the Test Menu leads to Submenu "Test Safety Valve".



Note

Prior to starting the Test, close all filling connections (also connected filling panels if necessary). During this test, the compressor passes the selected stop pressure (see Menu M320) to test the correct function of the final pressure safety valve. This would limit the maximum operating over pressure of the unit in case of malfunction.

B

Test

Safety Valve

Close Filling Valves!

5 Start	0 Stop
9 Close	
(M430) Return : #	

Key 5 to start test Key 0 to stop test

Key 9 leads back to submenu „Test“

Key # leads back to "Main Menu"

Test stop without venting (M440)

Pushing key 4 in the Test Menu leads to Menu "Test Stop without Venting".



Note

This test is only operable when the compressor has been started with key 1. This test mainly checks the leak tightness of pressure vessels, pressurised pipes, safety valves and the compressor block.

Test

stop without venting:

5 Stop	
6 Vent	
Pressure	0
	bar
9 Close	
(M440) Return : #	

Key 5 stops compressor during test run

Key 6 vents compressor after leak search has been finished

Shows current filling pressure

Key 9 leads back to submenu „Test“

Key # leads back to "Main Menu"



OPERATION AND FUNCTION

Statistics Menu (M500)

Pushing key 5 in the Selection Menu leads to Submenu "Statistics".

Statistics	
Operation Hours:	0,0 h
Start cycles:	00
Max Press	000 bar
9	Close
(M500)	Return : #

Total operation hours of compressor unit

Total number of compressor starts

Maximum working pressure of unit (set by safety valve test)

Key 9 leads back to submenu „Selection“

Key # leads back to "Main Menu"

Push key 5 to get information on which ECC software version is currently installed on your system (M505), i.e.: By pushing key 2, the total load cycles of the filter housing are being indicated.

B

OPERATION AND FUNCTION

Maintenance Menu (M600)

Pushing key 6 in the Selection Menu leads to the "Maintenance Menu".

Hours remaining		
Oil change	14 h	Shows remaining hours of listed components (i.e. next oil change in 14 hours,...)
Sinter filt	989 h	
Silencer	4989 h	
Valves	5989 h	
Oil filter	1000 h	
8 Change done		Key 8 leads to submenu "Receipt Maintenance"
9 Close		Key 9 leads back to submenu „Selection“
(M600) Return : #		Key # leads back to "Main Menu"

Remaining hours depend on the type. At the end of any remaining hours, the display indicates a warning message. Furthermore, the display informs about any possibly necessary spare parts with the corresponding L&W service part number.



Attention during maintenance

During automatic mode, the compressor can automatically start by itself at any time, depending on the selected restart pressure (see "Set Restart Pressure" M330).



OPERATION AND FUNCTION

Confirm Maintenance (M680)

Confirm Maintenance	
2	Oil change
3	Sinter filters
4	Silencer
5	Valves
6	Oil filter
(M680)	Return : #

Key 2 receipts oil change
Key 3 receipts change of sinter filters
Key 4 receipts change of silencer
Key 5 receipts change of valves
Key 6 receipts oil filter
Key # leads back to "Main Menu"

B

Display confirms any reset of "Hours remaining" with the following message:

Confirm Maintenance	
Operation Hours Meter Set	
9	Close
(M680)	Return : #

Key 9 leads back to submenu "Hours remaining"
Key # leads back to "Main Menu"

OPERATION AND FUNCTION

Operation Mode (M700)

Pushing key 7 in the Selection Menu leads to the menu "Operation Mode".

Activated modes are always displayed in bolt letters (above example: **Semi-Automatic**).

Further settings can be made in the Settings Menu (M300).

B

Betriebsart:	
2	Automatic
3	Semi-Automatic
4	bar /mpa
5	Sprache
9	Close
(M700)	Return : #

Key 2 activates automatic mode

Key 3 activates semi-automatic mode

Key 4 selects between bar and MPa (optional)

Key 5 leads to the "Language Menu"

Key 9 leads back to submenu „Selection“

Key # leads back to "Main Menu"

Language Menu (M750)

Language Menu	
2	German
3	English
4	French
5	Spanish
6	Dutch
7	Language II
(M750)	Return : #

Key 7 optional language (e.g. Chinese)

Key # leads back to "Main Menu"

OPERATION AND FUNCTION

Adjusting Display Backlight

The brightness of the display can be adjusted with an adjusting screw on the back of the control.

Software Update

Software updates can only be carried out by L&W. To carry out an update, the device has to be send to the L&W service.



Adjust brightness

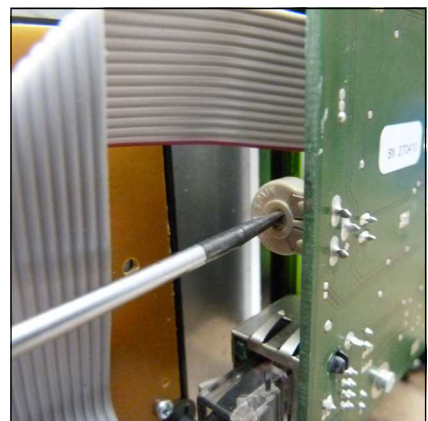

Adjust brightness

SPARE PART LISTS

Best.-Nr. / Order No.	Benennung	Description
002141	1. Stufe Druckaufnehmer 0-10 bar	1st stage pressure sensor 0-10 bar
002142	2. Stufe Druckaufnehmer 0-60 bar	2nd stage pressure sensor 0-60 bar
003888	3. Stufe Druckaufnehmer 0-100 bar	3rd stage pressure sensor 0-100 bar
002143	Endstufe Druckaufnehmer 0-400 bar	Final stage pressure sensor 0-400 bar
006890	Druckaufnehmer 420 bar Version 0-600 bar	Pressure sensor 420 bar version 0-600 bar
004840	Öldruckaufnehmer 0-6 bar	Oil pressure sensor 0-6 bar
006912	Öltemperatursensor	Oil temperature sensor
003501	Zylinderkopf - Temperatursensor	Cylinderhead temperature sensor

B



002141 / 002142 / 002143 / 003888 / 004840
Druckaufnehmer / Pressure sensor



006890 - Druckaufnehmer 420 bar /
Pressure sensor 420 bar



006912 - Öltemperatursensor
Oil temperature sensor



003501 - Zylinderkopf - Temperatursensor
Cylinderhead temperature sensor



LENHARDT & WAGNER GMBH

B

Manufacturer in terms of 97/23/EC

The full name and address of the manufacturer is:

Lenhardt & Wagner GmbH

An der Tuchbleiche 39
68623 Hüttenfeld / Germany

Phone: +49 (0) 62 56 - 85 88 0 - 0

Fax: +49 (0) 62 56 - 85 88 0 - 14

E-Mail: service@lw-compressors.com

Internet: www.lw-compressors.com



www.uebler.net



**ERSATZTEILLISTEN / SPARE PARTS LISTS
DETAILANSICHTEN / DETAILED VIEWS**

C



Inhaltsverzeichnis - Table of Contents

Gehäuse - Housing	3
Schalttafel - Control Board.....	5
Verrohrung - Piping.....	7
Kompressorblock - Compressor Block	9
Kurbelwelle - Crankshaft.....	13
Kolben 1. Stufe - Piston 1st Stage	15
Kolben 2. Stufe - Piston 2nd Stage.....	17
Kolben 3. Stufe - Piston 3rd Stage	19
Kolben 4. Stufe - Piston 4th Stage	21
Ventil 1. Stufe - Valve 1st Stage	23
Ventil 2. Stufe - Valve 2nd Stage.....	25
Ventil 3. Stufe - Valve 3rd Stage	27
Ventil 4. Stufe - Valve 4th Stage	29
Ölpumpe - Oil Pump.....	31
Ansaugfilter - Air Intake Filter	33
Kühler 1. Stufe - 1st Stage.....	35
Kühler 2. Stufe - Cooler 2nd Stage	37
Kühler 3.&4. Stufe - Cooler 3rd&4th Stage	39
Öl- Wasserabscheider 1. Stufe - Oil- Water Separator 1st Stage	41
Öl- Wasserabscheider 2. Stufe - Oil- Water Separator 2nd Stage.....	43
Öl- Wasserabscheider 3. Stufe - Oil- Water Separator 3rd Stage.....	45
Filtergehäuse 1,7 l - Filter Housing 1.7 ltr	47
Druckhalteventil - Pressure Maintaining Valve.....	49
Sicherheitsventil - Safety Valve	51
Motor	53



Inhaltsverzeichnis - Table of Contents

Lüfterrad - Cooling Fan	55
Ölablassschlauch - Oil Drainage Tube	57
Füllschlauch - Filling Hose	59
Kreuzventil - Cross Design Valve	60



ERSATZTEILLISTE / SPARE PART LIST

Gehäuse / Housing

Best.-Nr. / Order No.	Benennung	Description
001041	Zylinderschraube	Allen Screw
001163	Mutter	Nut M10
001182	U-Scheibe A8	Washer A8
001186	U-Scheibe A10	Washer A10
005437	Standfuß, Höhenverstell. mit Gummieinl.	Foot, Height adjustable Ø80 mm
009752	Steckhalter Kreuzventil	Holder Filling Valve cross
009761	O-Ring	O-Ring
009762	Grundkonsole	Compressor Console
009764	Ventilatorschutz	Protective cover, fan

C

DETAILANSICHT / DETAILED VIEW

Gehäuse / Housing

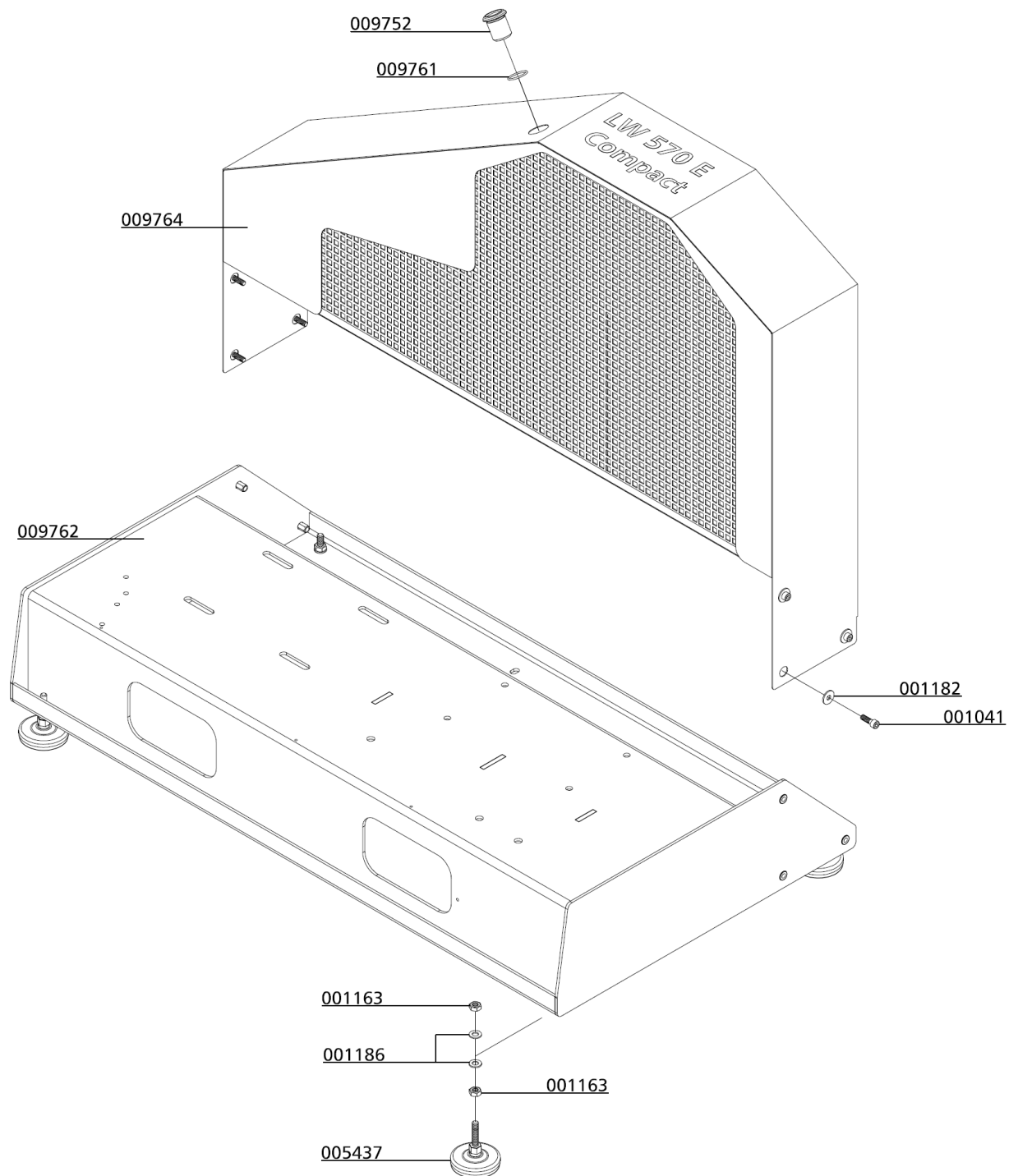

C



ERSATZTEILLISTE / SPARE PART LIST

Baugruppe: Schalttafel / Control Board

Best.-Nr. / Order No.	Benennung	Description
001841	Ein / Aus Schalter	On / Off Switch
002089	Betriebsstundenzähler 230 Volt	Hour counter 230 V
003121	Not-Aus Schalter komplett	Emergency switch compl.
007981	Aufkleber NOT-AUS, rund	Emergency-Off Sticker
009763	Einlegeschild "Start / Stop"	Label Start / Stop
009765	Schildträger, ohne Schild	Legend plate mount

C

DETAILANSICHT / DETAILED VIEW

Baugruppe: Schalttafel / Control Board

C

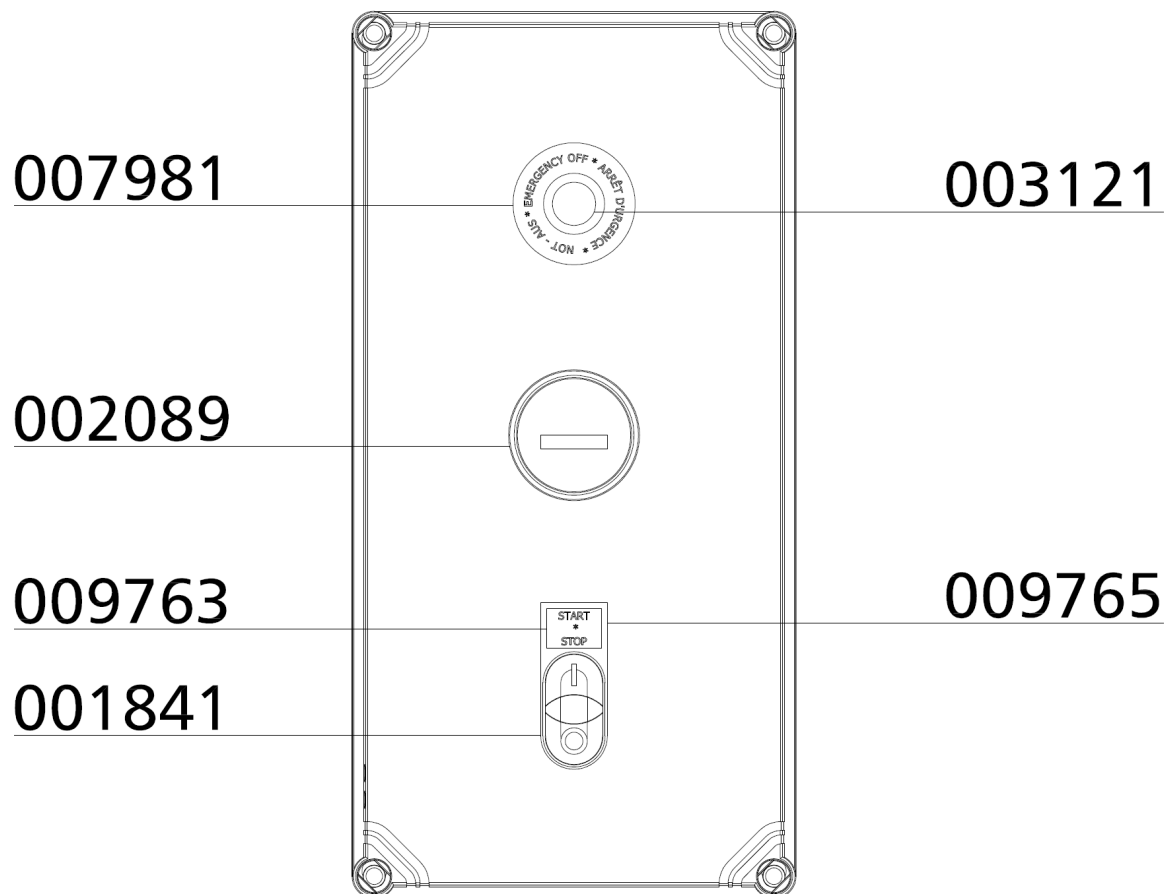



ERSATZTEILLISTE / SPARE PART LIST

Verrohrung / Piping

Best.-Nr. / Order No.	Benennung	Description
000335	Rohrleitung 8mm	Pipe 8mm
000336	Rohrleitung 8mm	Pipe 8mm
000337	Rohrleitung 15mm	Pipe 15mm
009766	Rohrleitungen Ø8mm, komplett mit Muttern	Pipe Ø8mm. c/w Nuts
009767	Rohrleitungen Ø8mm, komplett mit Muttern	Pipe Ø8mm. c/w Nuts
009768	Rohrleitungen Ø8mm, komplett mit Muttern	Pipe Ø8mm. c/w Nuts
009769	Rohrleitungen Ø8mm, komplett mit Muttern	Pipe Ø8mm. c/w Nuts

C

DETAILANSICHT / DETAILED VIEW

Verrohrung / Piping

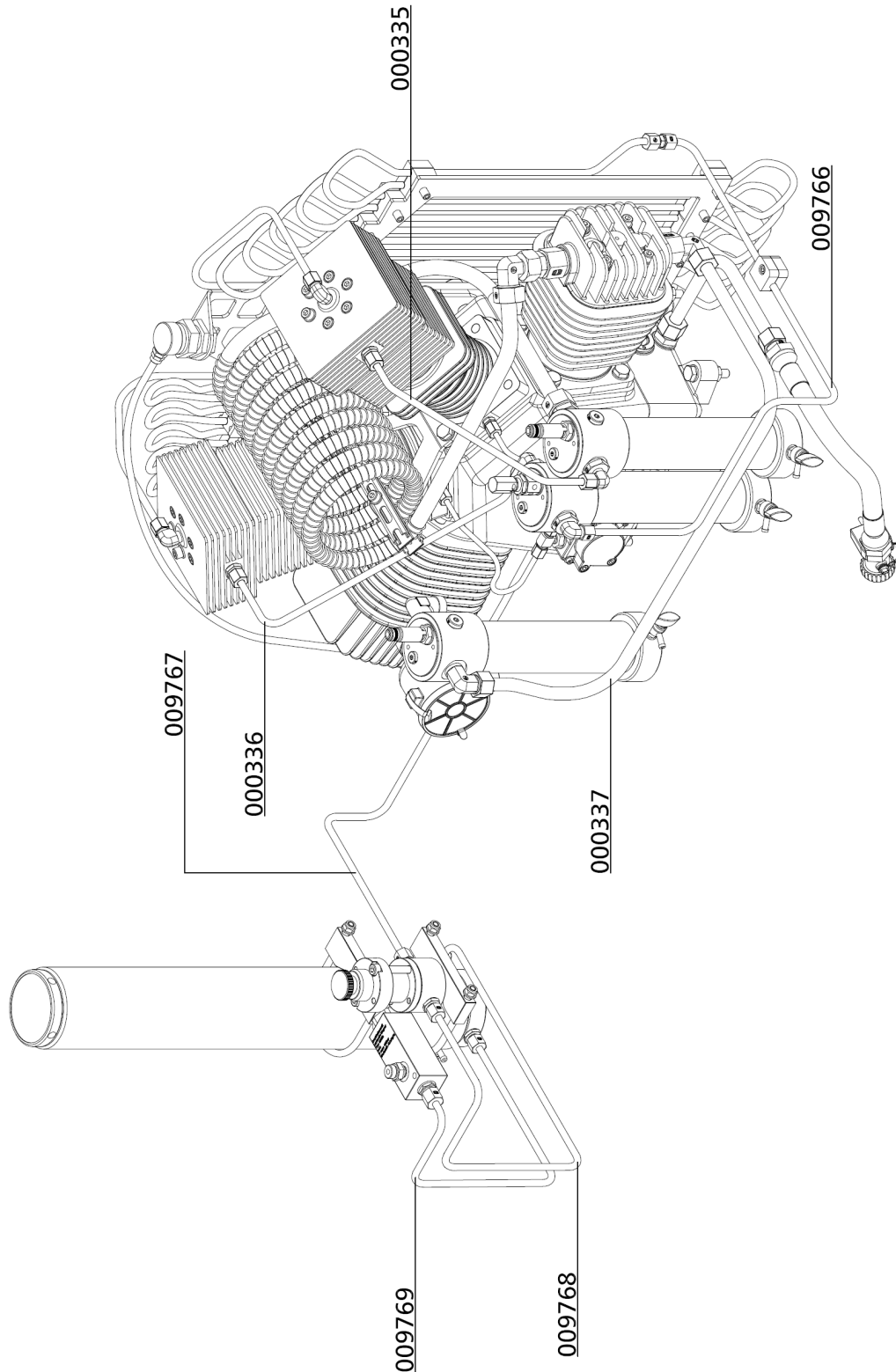



ERSATZTEILLISTE / SPARE PART LIST

Baugruppe: Kompressorblock / Assembly: Compressor Block

Best.-Nr. / Order No.	Benennung	Description
000180	Ölschlauchstutzen	Oil hose clip
000239	Kugellager	Ball Bearing
000240	Papierdichtung Zylinderflansch / Block	Paper Gasket Cylinder Flange
000241	Dichtung Lagerflansch	Gasket Bearing Flange
000243	Lagerring	Bearing Bush
000244	Wellendichtung	Shaft Seal
000254	Obere Ventildichtung für Ventil 2. Stufe, Papier	Upper Valve Gasket, Paper, 2nd
000270	Ventilkopf für Ventil, 2. Stufe Ø71mm	Valve Head for Valve 2nd Stage Ø 71mm
000273	Lagerdeckel	Main Bearing Flange
000341	Kurbelgehäuse LW 570	Crankcase LW 570
000343	Zylinder 3. Stufe Ø25mm	Cylinder 3rd Stage Ø25mm
000344	Führungszylinder, 3. + 4. Stufe Ø50mm	Guide Cylinder 3rd/4th Stage, Ø50 mm
000346	Zylinder 4. Stufe Ø14mm	Cylinder 4th Stage Ø14mm
000349	Obere Ventildichtung für Ventil, Ø122mm	Upper Valve Gasket, Ø122mm
000350	Untere Ventildichtung 1.Stufe, Kupfer	Lower Valve Gasket, 1st Stage, Copper
000351	Zylinder, 1. Stufe Ø105 mm	Cylinder 1st Stage Ø105 mm
000353	Sicherungsring I 90 DIN472	Circlip 90 DIN472
000357	Rohrleitung 15mm Edelstahl	Pipe 6mm s/s
000409	O-Ring, 1. Stufe, Zylinderflansch	O-Ring - 1st Stage
000410	Pleuel, 2., 3. & 4. Stufe	Conrod, 2nd, 3rd. & 4th. Stage
000411	Pleuel, 1. Stufe	Conrod 1st Stage
000412	O-Ring, Oelsaugschraube	O-Ring
000413	Sicherungsring AL40	Circlip AL40
000414	Distanzhülse Kühlerhalter, Ø16xØ12x12,5mm, V2A	Spacer Cooling Bracket, Ø16xØ12x12,5mm, s/s
000498	U-Scheibe A6	Washer A6
000738	Verschraubung GE 08 PLR 1/4"	Connection GE 08 PLR 1/4"
000761	Verschraubung WE 08 PLR CFX 1/4"	Elbow Connection WE 08 PLR CFX 1/4"
000815	Verschraubung G 15L	Connection G 15L
000818	Verschraubung GE 15L R1/2"	Connection GE 15L R1/2"
000839	Verschlussstopfen VSTI R3/8" ED	Plug VSTI R3/8" ED



ERSATZTEILLISTE / SPARE PART LIST

Baugruppe: Kompressorblock / Assembly: Compressor Block

Best.-Nr. / Order No.	Benennung	Description
000863	Verschraubung WE 18L R A3C	Elbow Connection WE 18L R A3C
000879	Verschraubung WEE 28L R	Connection WEE 28L R
000919	Reduzierung/Reducer RI 3/4"-1/2"	Reducer RI 3/4"-1/2"
000961	Stiftschraube M8x25mm DIN939	Threaded Stud M8x25mm DIN939
001029	Zylinderschraube M6x20mm DIN912 8.8 ZN	Allen Bolt M6x20mm DIN912 8.8 ZN
001041	Zylinderschraube M8x25mm DIN912 8.8 ZN	Allen Bolt M8x25mm DIN912 8.8 ZN
001056	Zylinderschraube M8x60mm DIN912 8.8 ZN	Allen Bolt M8x60mm DIN912 8.8 ZN
001058	Zylinderschraube M8x70mm DIN912 8.8 ZN	Allen Bolt M8x70mm DIN912 8.8 ZN
001060	Zylinderschraube M8x80mm DIN912 8.8 ZN	Allen Bolt M8x80mm DIN912 8.8 ZN
001190	Federring, A10 DIN127 ZN	Spring Washer, A10 DIN127 ZN
001092	Zylinderschraube M10x80mm DIN912 8.8 ZN	Allen Bolt M10x80mm DIN912 8.8 ZN
001100	Sechskant Schraube M10x25mm DIN933 8.8	Hexagon Screw M10x32mm DIN933 8.8 ZN
001104	Sechskant Schraube, M10x50mm DIN933 8.8 ZN	Hexagon Screw, M10x50mm DIN933 8.8 ZN
001114	Sechskant Schraube, M10x120mm DIN933 8.8 ZN	Hexagon Screw, M10x120mm DIN933 8.8 ZN
001133	Sechskantschraube M12x30mm DIN933 8.8 ZN	Hexagon Screw M12x30mm DIN933 8.8 ZN
001158	Mutter M8 DIN934 ZN	Nut M8 DIN934 ZN
001163	Mutter M10 DIN934 ZN	Nut M10 DIN934 ZN
001181	U-Scheibe A8 DIN125 ZN	Washer A8 DIN125 ZN
001184	Schnorr-Scheibe, S8 N0110 ZN	Clamp Washer, S8 N0110 ZN
001186	U-Scheibe A10 DIN125 ZN	Washer A10 DIN125 ZN
001187	U-Scheibe A10 DIN7349 ZN	Washer A10 DIN7349 ZN
001191	U-Scheibe A12 DIN125 ZN	Washer A12 DIN125 ZN
001274	O-Ring	O-Ring
001323	Cu-Ring Ø10 x 16 x 2mm DIN7603A	Copper Seal Ring Ø10 x 16 x 2mm DIN7603A
001362	Sicherungsring I 72 DIN472	Circlip I 72 DIN472
002367	Ventilkopf LW 450 (3. Stufe) / LW 570 (4. Stufe)	Valve head LW 450 (3rd Stage), LW 570 (4th Stage)
002932	Distanzbolzen mit M6 Gewinde	Spacer
003142	Ventilkopf 1. Stufe	Valve head, 1st stage
003281	Nadellager Pleuel, 2., 3. & 4. Stufe	Needle bearing, con-rod, 3rd. & 4th. Stage



ERSATZTEILLISTE / SPARE PART LIST

Baugruppe: Kompressorblock / Assembly: Compressor Block

Best.-Nr. / Order No.	Benennung	Description
003286	Oelschauglas LW 450 / LW 570 / LW 1300	Oil gauge glass LW 450 / LW 570 / LW 1300
003492	Untere Ventildichtung, Ø52 x 71,1 x 1,0 Alu	Lower valve gasket, Ø52 x 71,1 x 1,0 alloy
004367	Ölansaugstopfen	Oil intake plug
005122	U-Scheibe 12,5x34,5mm, Kurbelwelle	Washer, crank shaft
006856	Zylinder Ø50 mm, 2. Stufe	Cylinder Ø50 mm, 2nd Stage
	BG Kurbelwelle	Ass: Crankshaft
	BG: Ventil 1.Stufe	Ass: Valve 1 st stage
	BG: Ventil 2.Stufe	ASS: Valve 2 nd stage
	BG: Ventil 3.Stufe	ASS: Valve 3 rd stage
	BG: Ventil 4.Stufe	ASS: Valve 4 th stage
	BG: Kolben 1.Stufe	Ass: Piston 1 st stage
	BG: Kolben 2.Stufe	ASS: Piston 2 nd stage
	BG: Kolben 3.Stufe	ASS: Piston 3 rd stage
	BG: Kolben 4.Stufe	ASS: Piston 4 th stage
	BG: Ansaugfilter	ASS: Piston 4 th stage

C

DETAILANSICHT / DETAILED VIEW

Baugruppe: Kompressorblock / Assembly: Compressor Block

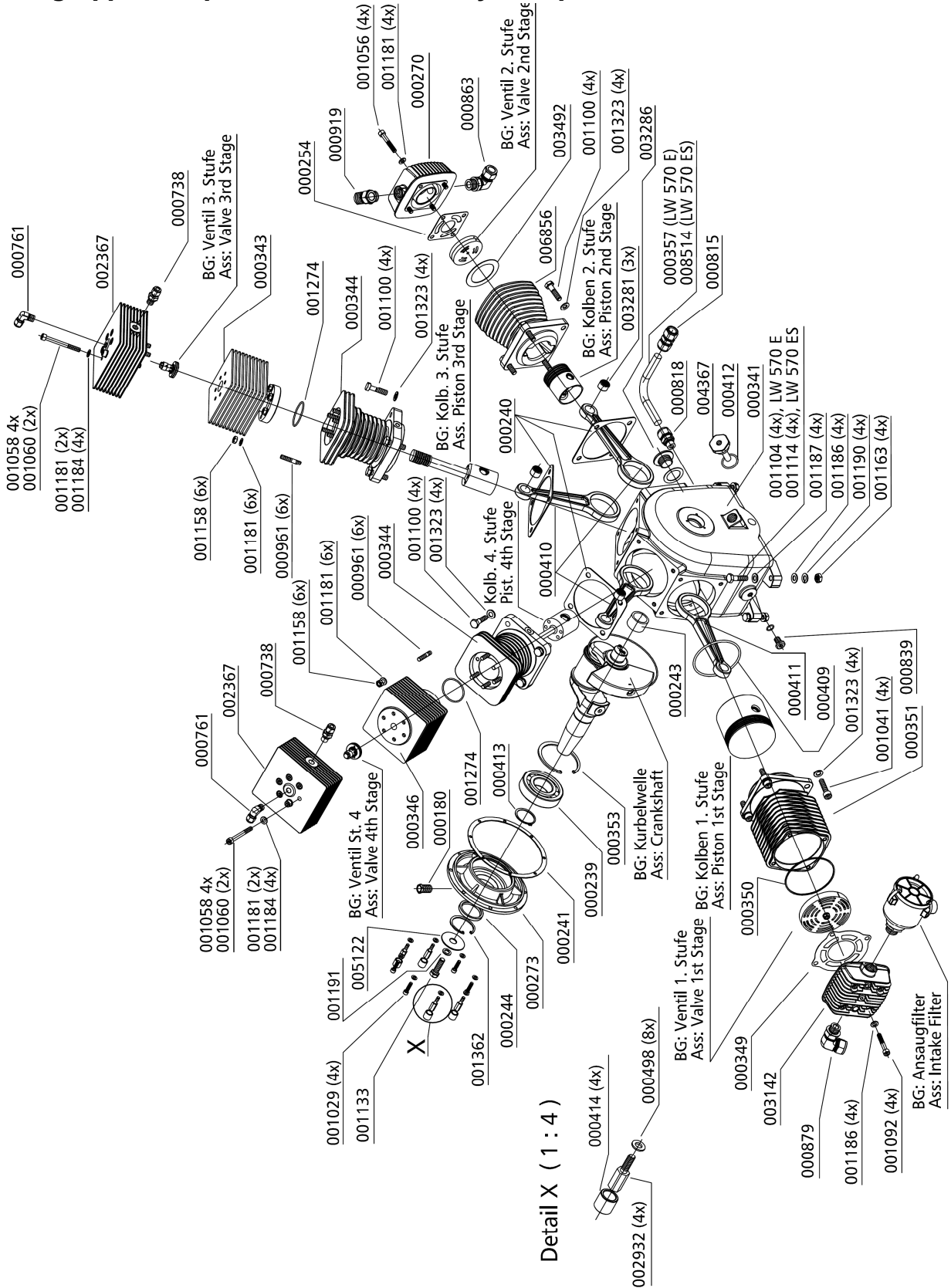



ERSATZTEILLISTE / SPARE PART LIST

Kurbelwelle / Crankshaft

Best.-Nr. / Order No.	Benennung	Description
000358	Kurbelwelle, komplett inkl. Gegengewicht	Crankshaft c/w Counter Weight
000374	Anlaufscheiben Kurbelwelle, 1 Paar	Thrust Washer Crankshaft pair
001184	Schnorr-Scheibe, S8 N0110 ZN	Clamp Washer, S8 N0110 ZN
001207	Passfeder DIN6885	Woodruff Key DIN6885
001350	Sicherungsring, A65 DIN471	Circlip A65, DIN471
004809	Ölpumpenmitnehmerschraube	Drive bolt
006775	Zylinderschraube, M10x55mm DIN912 10.9	Hexagon Bolt, M10x55mm DIN912 10.9

C

DETAILANSICHT / DETAILED VIEW

Kurbelwelle / Crankshaft

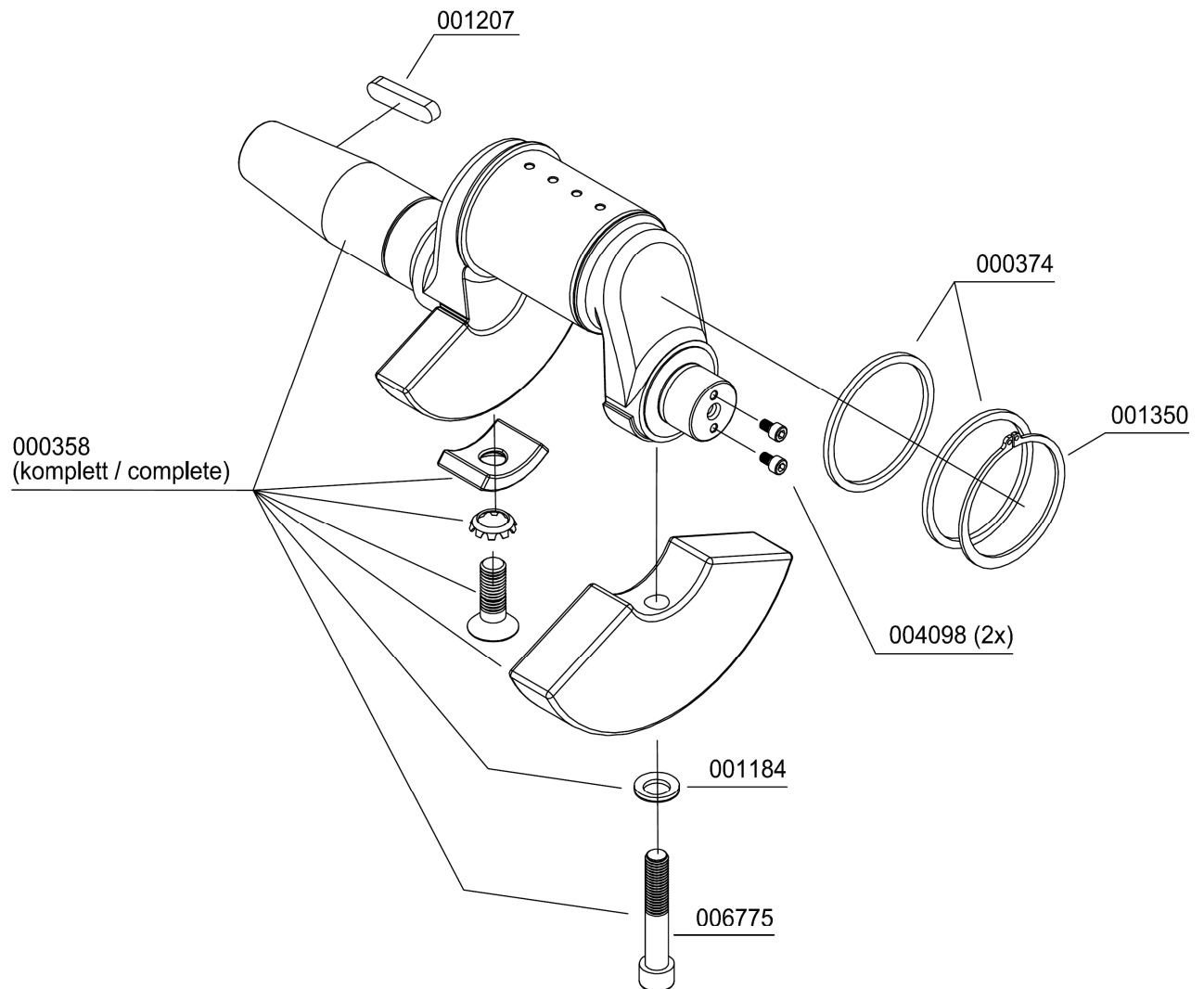

C



ERSATZTEILLISTE / SPARE PART LIST

Kolben 1. Stufe / Piston 1st Stage

Best.-Nr. / Order No.	Benennung	Description
000359	Kolben, 1. Stufe, Ø105mm	Piston 1st Stage Ø105 mm
000360	Kolbenringsatz 1. Stufe Ø105mm	Set Piston Rings 1st Stage Ø105mm
000361	Kolbenbolzen, 1. Stufe Ø25x90 mm	Piston Pin Ø25x90mm
001358	Sicherungsring I 25 DIN472	Circlip I 25 DIN472

C

DETAILANSICHT / DETAILED VIEW

Kolben 1. Stufe / Piston 1st Stage

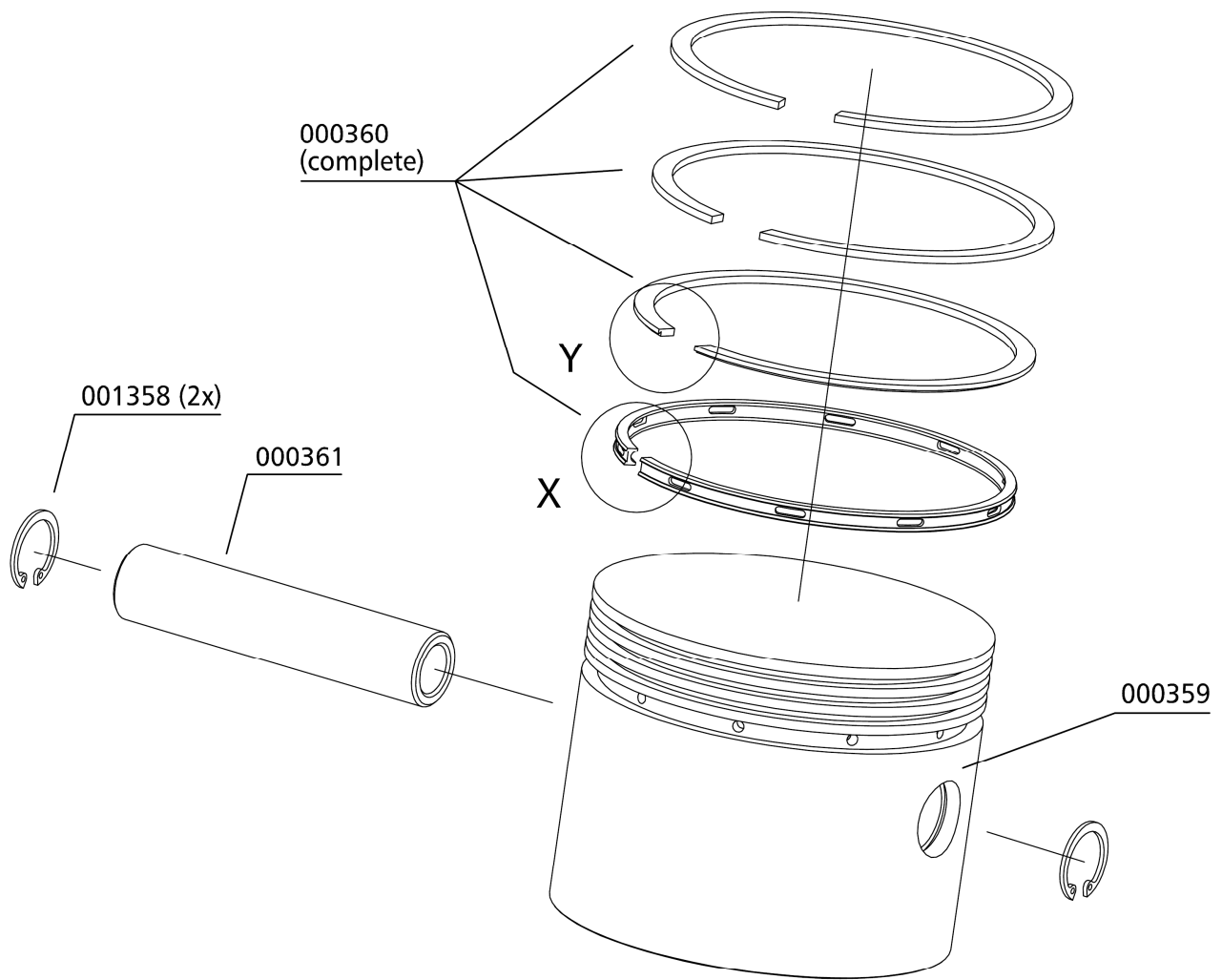

X (1:1)

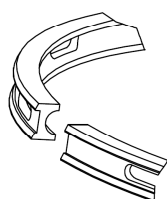

Y (1:1)

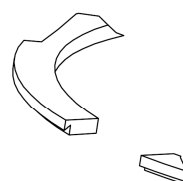



ERSATZTEILLISTE / SPARE PART LIST

Kolben 2. Stufe / Piston 2nd Stage

Best.-Nr. / Order No.	Benennung	Description
000362	Kolben, 2. Stufe	Piston 2nd Stage
000363	Kolbenringsatz 2. Stufe, Ø50mm	Set Piston Rings 2 nd Stage Ø50mm
000373	Kolbenbolzen, 2. / 3. / 4. Stufe	Piston Pin, 2 nd Stage
001356	Sicherungsring, I 22 DIN472	Circlip I22 DIN472

C

DETAILANSICHT / DETAILED VIEW

Kolben 2. Stufe / Piston 2nd Stage

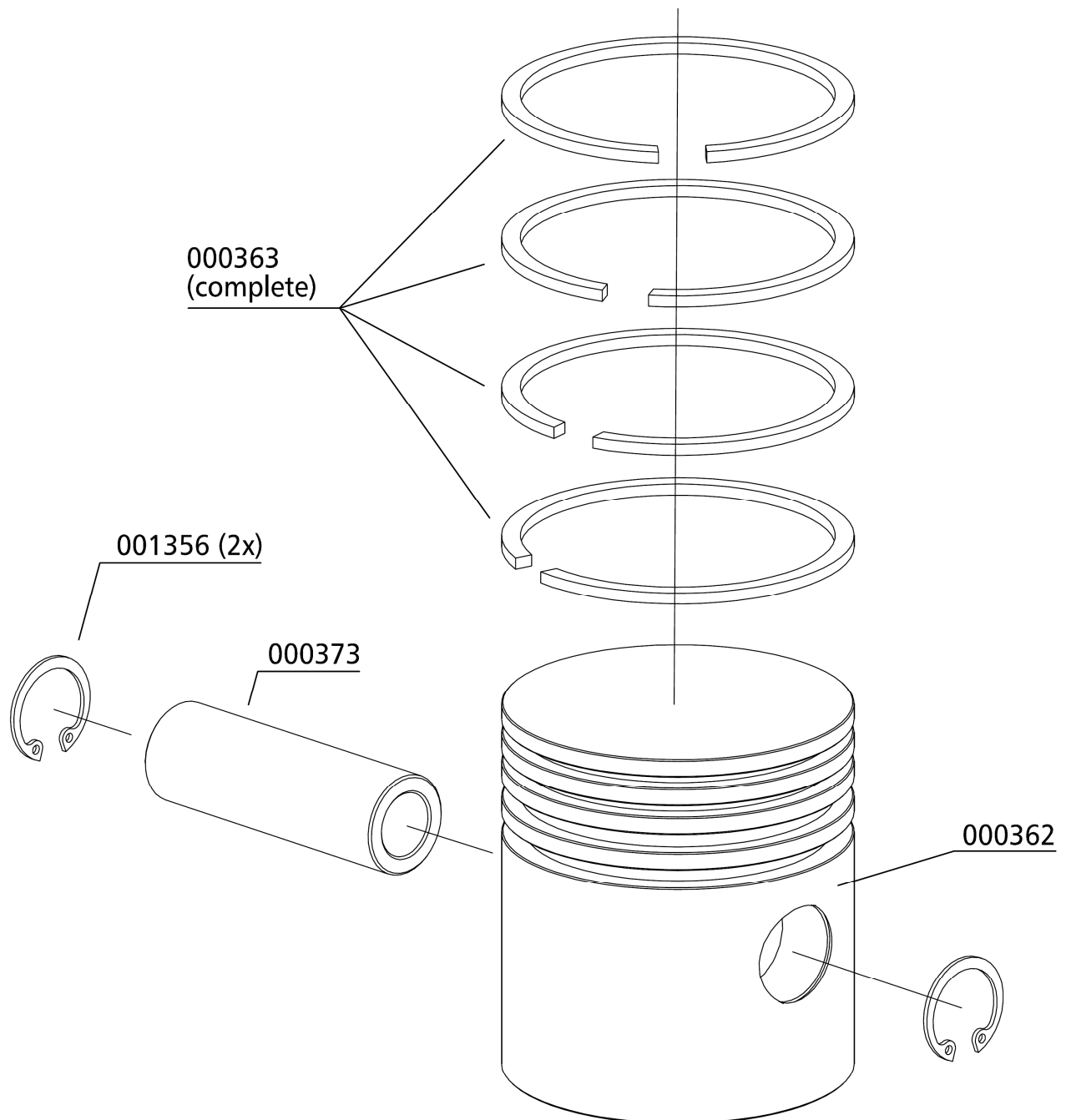

C



ERSATZTEILLISTE / SPARE PART LIST

Kolben 3. Stufe / Piston 3rd Stage

Best.-Nr. / Order No.	Benennung	Description
000365	Kolbenringsatz Ø25mm	Set Piston Rings Ø25mm
000366	Kolben Ø25mm/50mm, 3. Stufe	Piston Ø25mm/50mm, 3rd Stage
000373	Kolbenbolzen Ø22 x 40mm	Piston Pin Ø22 x 40mm
001356	Sicherungsring, I 22 DIN472	Circlip I22 DIN472
008325	Kolben Ø25/50, komplett	Piston Ø25/50, complete

C

DETAILANSICHT / DETAILED VIEW

Kolben 3. Stufe / Piston 3rd Stage

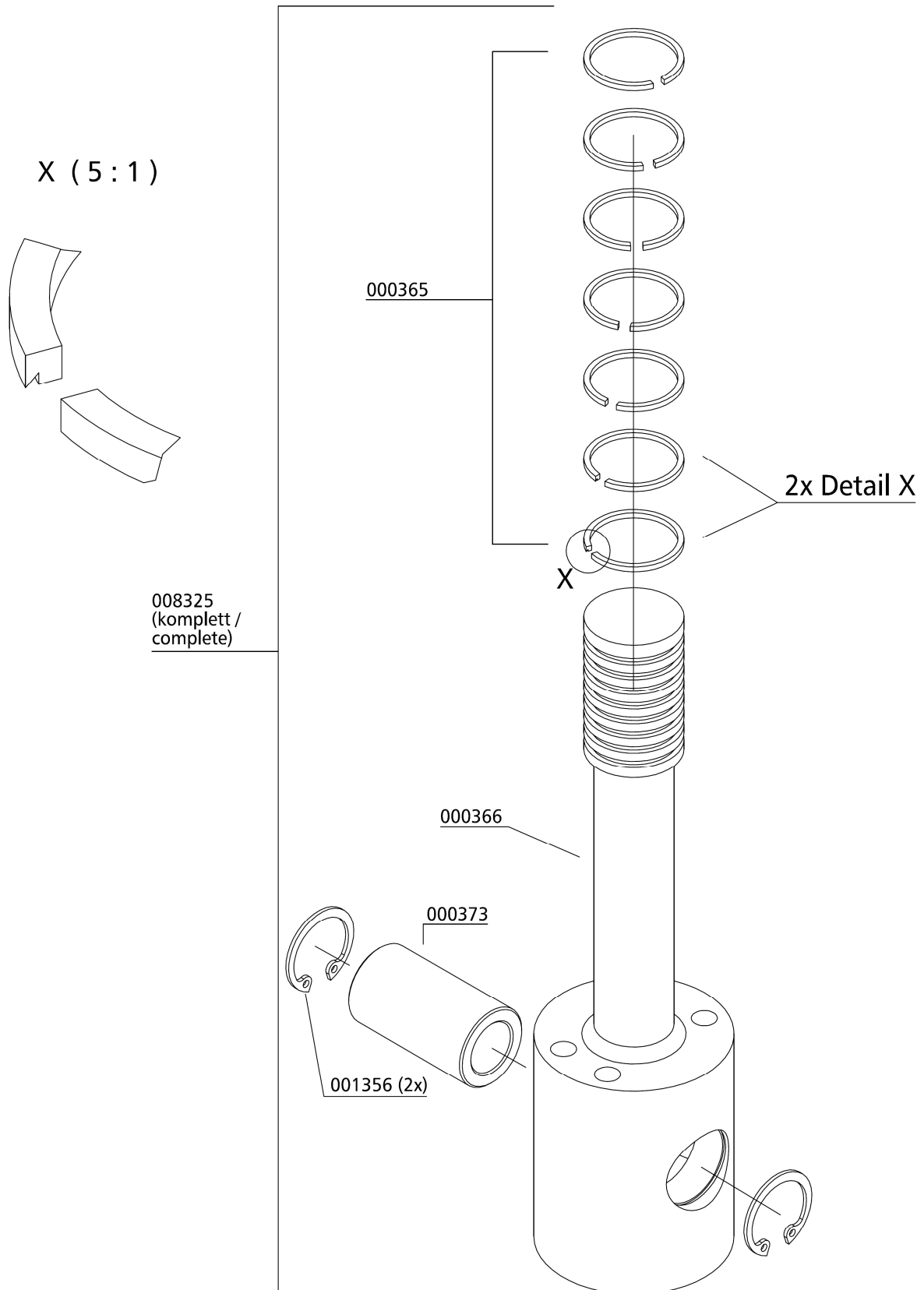



ERSATZTEILLISTE / SPARE PART LIST

Kolben 4. Stufe / Piston 4th Stage

Best.-Nr. / Order No.	Benennung	Description
000367	Kolbenringsatz Ø14mm	Set Piston Rings Ø14mm
000368	Kolben Ø14mm/50mm, komplett	Piston Ø14mm/50mm, complete
000373	Kolbenbolzen Ø22 x 40 mm	Piston Pin Ø22 x 40 mm
001356	Sicherungsring I 22 DIN472	Circlip I 22 DIN472
007432	Kolben Ø14mm/50mm	Piston Ø14mm/50mm

C

DETAILANSICHT / DETAILED VIEW

Kolben 4. Stufe / Piston 4th Stage

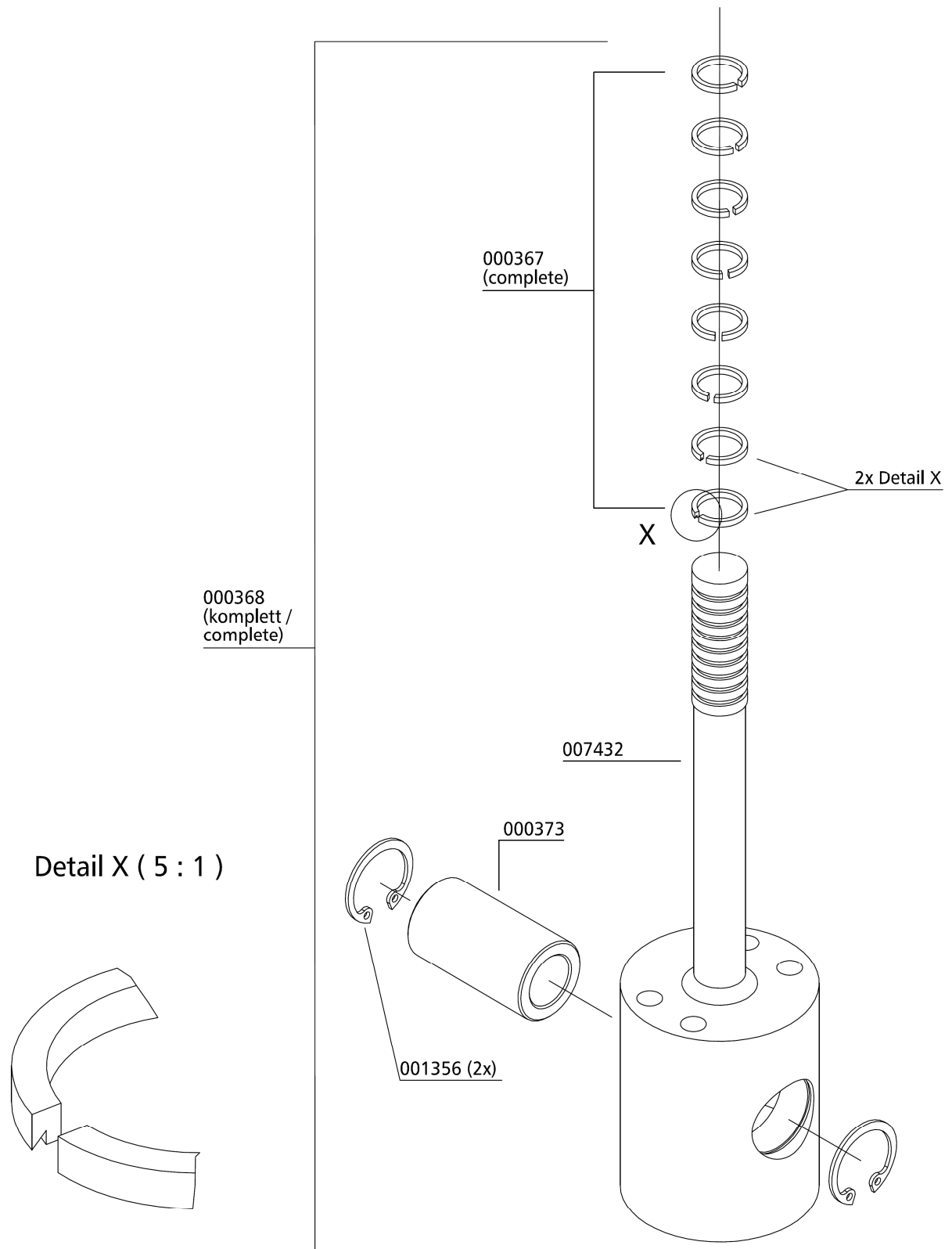



ERSATZTEILLISTE / SPARE PART LIST

Ventil 1. Stufe / Valve 1st Stage

Best.-Nr. / Order No.	Benennung	Description
000369	Saug- Druckventil, 1. Stufe	In-&Outlet Valve, 1st Stage

C

DETAILANSICHT / DETAILED VIEW

Ventil 1. Stufe / Valve 1st Stage

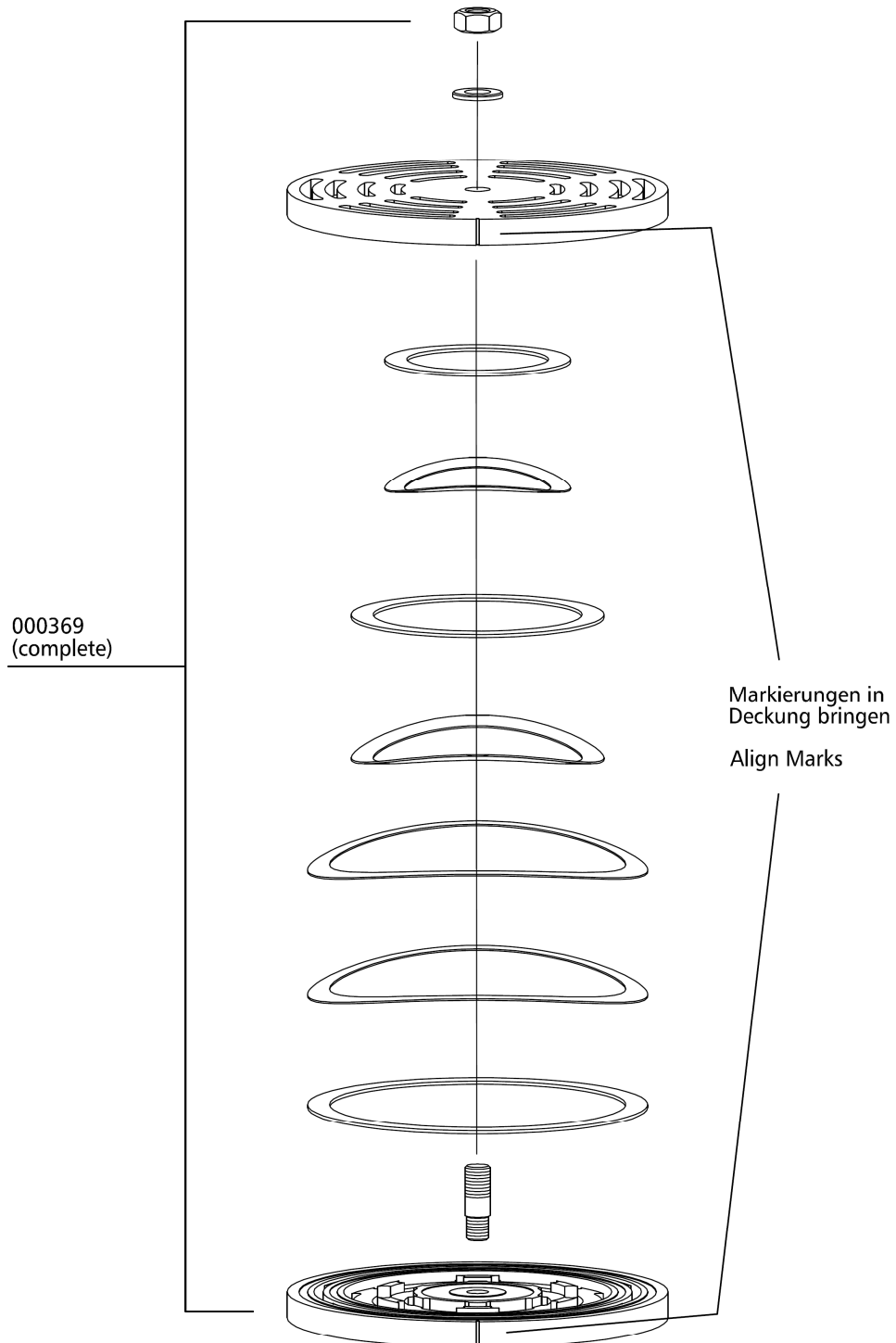



ERSATZTEILLISTE / SPARE PART LIST

Ventil 2. Stufe / Valve 2nd Stage

Best.-Nr. / Order No.	Benennung	Description
000256	Saug- und Druckventil 2. Stufe	In- & Outlet Valve comp.2nd Stage

C

DETAILANSICHT / DETAILED VIEW

Ventil 2. Stufe / Valve 2nd Stage

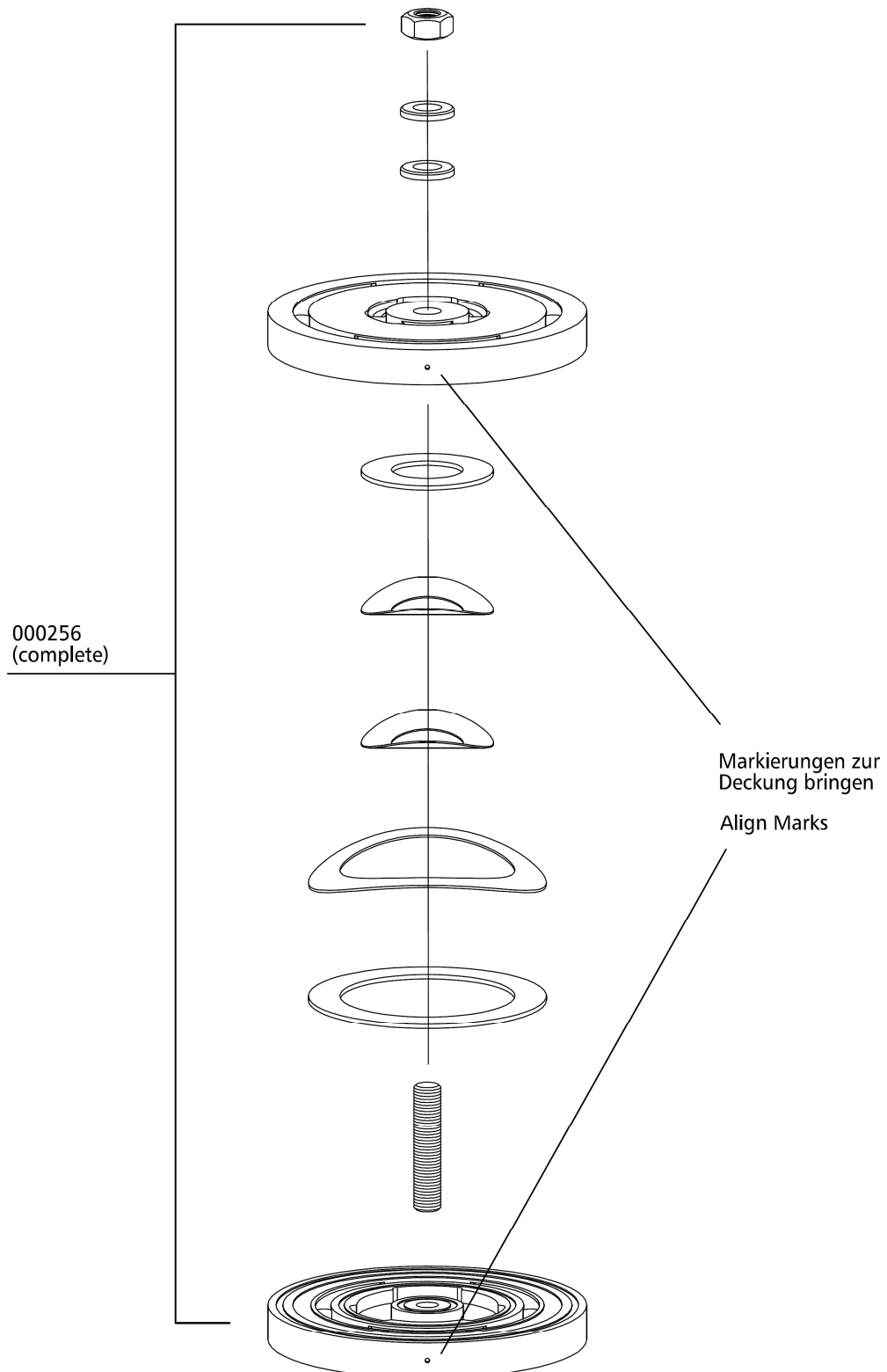



ERSATZTEILLISTE / SPARE PART LIST

Baugruppe: Ventil 3. Stufe / Assembly: Valve 3rd Stage

Best.-Nr. / Order No.	Benennung	Description
000533	Ventildichtung, Saug-& Druckventil unten	Lower Valve Gasket, 3rd Stage
000540	Dichtring / Dichtung, 3. Stufe	Upper Alloy Seal Ring, 3rd Stage
000544	Saug-Druckventil, 3. Stufe, Komplett	In- & Outlet Valve, 3rd Stage

C

DETAILANSICHT / DETAILED VIEW

Baugruppe: Ventil 3. Stufe / Assembly: Valve 3rd Stage

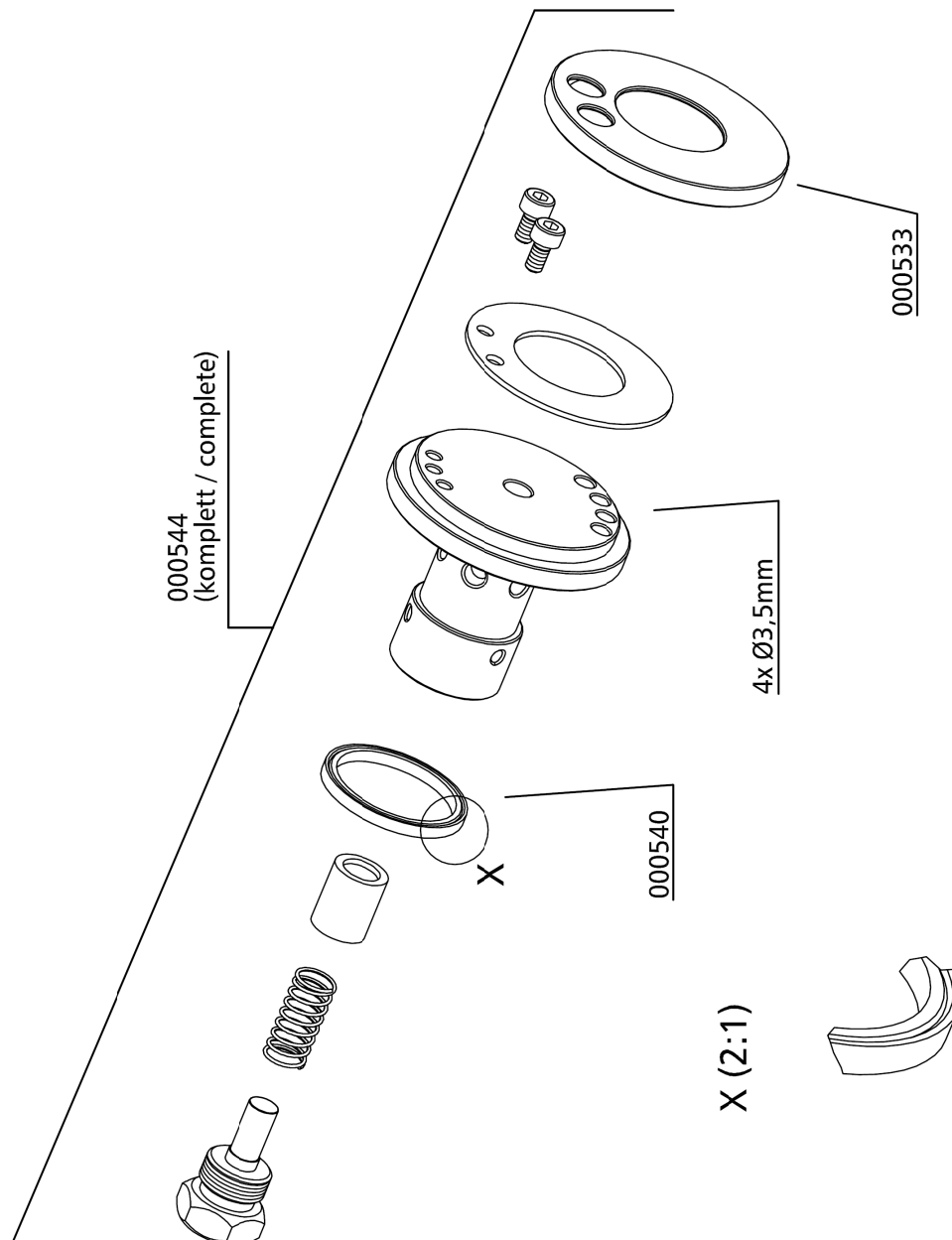



ERSATZTEILLISTE / SPARE PART LIST

Ventil 4. Stufe / Valve 4th Stage

Best.-Nr. / Order No.	Benennung	Description
000534	Ventildichtung, Saug- & Druckventil, Typ 44/15/36-0,3, Al	Lower Valve Gasket, Type 44/15/36-0,3, Alloy
000540	Dichtring, Saug- u. Druckventil oben, Al	Upper Alloy Seal Ring, Alloy
000545	Saug-Druckventil, inkl. Dichtungen	In- & Outlet Valve, c/w gaskets

C

DETAILANSICHT / DETAILED VIEW

Ventil 4. Stufe / Valve 4th Stage

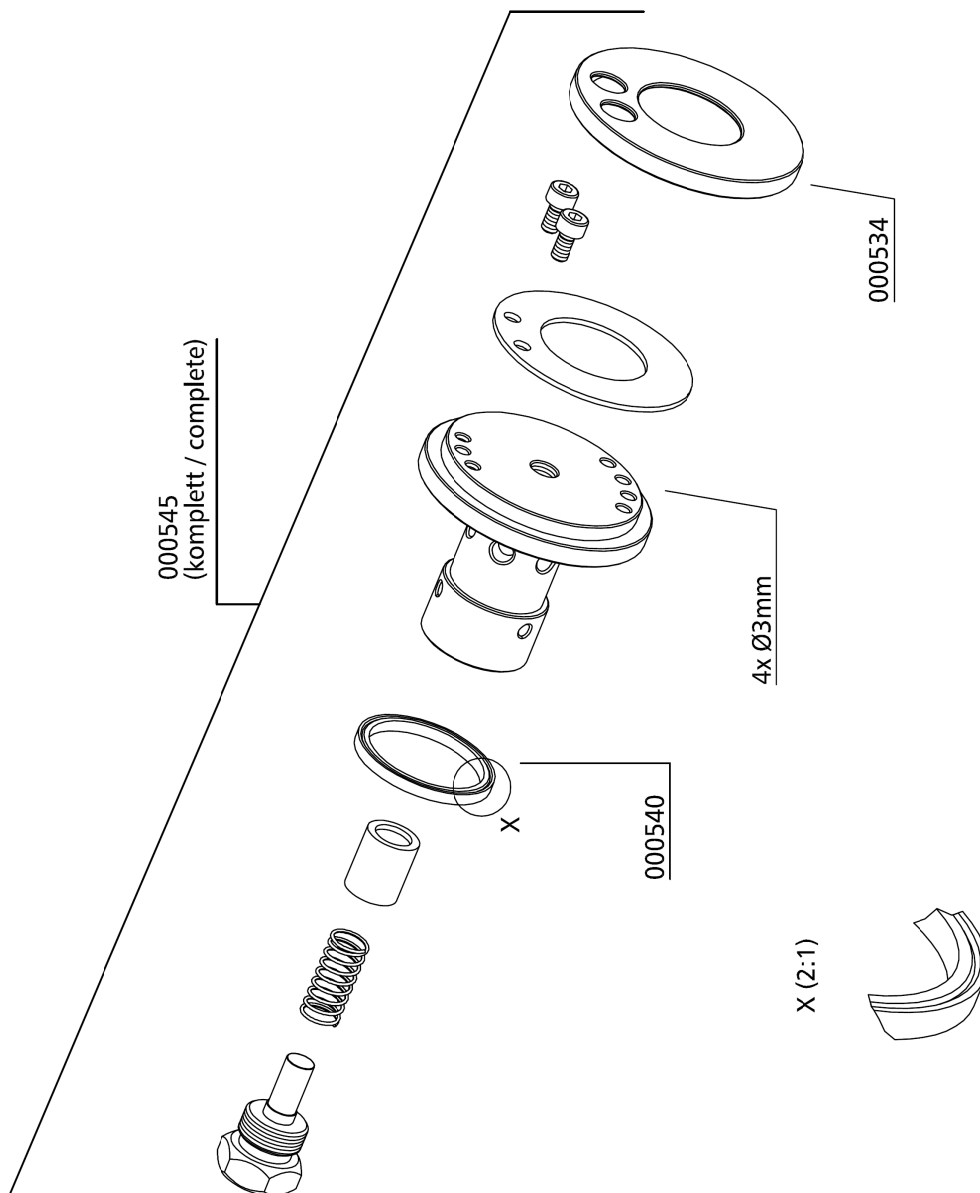

C



ERSATZTEILLISTE / SPARE PART LIST

Ölpumpe / Oil Pump

Best.-Nr. / Order No.	Benennung	Description
000200	Ölpumpenhalteflansch	Adapter Flange Oil Pump
000204	Oelpumpe, kompl.	Oil Pump compl.
000208	Oelpumpenantriebsflansch	Drive Flange Oil Pump
000250	CU-Ring Ø6,2 x 10 x 1,5mm DIN7603A	Copper Washer Ø6,2 x 10 x 1,5mm DIN7603A
000355	Rohrleitung Ø6	Pipe Ø6
000356	Rohrleitung Ø6	Pipe Ø6
000710	Verschraubung ohne Mutter & Schneidring GE 06 PLR 1/8" ED X	Connection w/o nut& olive seal GE 06 PLR 1/8" ED X
000712	Verschraubung ohne Mutter & Schneidring GE 06PLR 1/4" ED	Connection w/o nut& olive seal GE 06PLR 1/4" ED
000716	Verschraubung ohne Mutter & Schneidring TE G1/8" / 6L	Connection w/o nut& olive seal TE G1/8" / 6L
000732	Mutter 06L	Nut 06L
000733	Schneidring SR 06	Olive Seal SR 06
000739	Verschraubung GE 08 L/1/4"	Connection GE 08 L/1/4"
000759	Verschraubung, mit Mutter & Schneidring WE 08 LL R 1/8"	Elbow connection c/w nut&olive WE 08 LL R 1/8"
000765	Schneidring PSR 08 LX	Olive Seal PSR 08 LX
000766	Mutter 08L	Nut 08L
000952	Sechskantschraube M6X20mm, DIN933, 8.8	Hexagon Bolt M6X20mm DIN933, 8.8
000958	Gewindestift M8x16mm DIN914, 5.8 ZN	Worm Screw M8x16mm DIN914 5.8 ZN
001014	Gewindestift mit Zapfen M6X16mm DIN915	Allen Screw with Pin M6X16mm DIN915
001021	Zylinderschraube M5x40mm DIN912 8.8 ZN	Allen Bolt M5x40mm DIN912 8.8 ZN
001151	Mutter M5 DIN934 ZN	Nut M5 M5 DIN934 ZN
001176	U-Scheibe A5 DIN125 ZN	Washer A5 DIN125 ZN
002340	O-Ring Ölpumpenflansch 32,2x3 NBR70	O-Ring, oil pump flange 32,2x3 NBR70
002395	Verschlusskegel 06mm	Locking cone 06mm
005261	Öldruckschalter 0,2 - 2 bar	Oil Pressure Switch 0.2-2 bar
005482	Halteblech Öldruckschalter	Bracket Oil Pressure Switch
005483	Rohrleitung Ø6	Pipe Ø6
005487	Rohrleitung Ø8	Pipe Ø8

DETAILANSICHT / DETAILED VIEW

Ölpumpe / Oil Pump

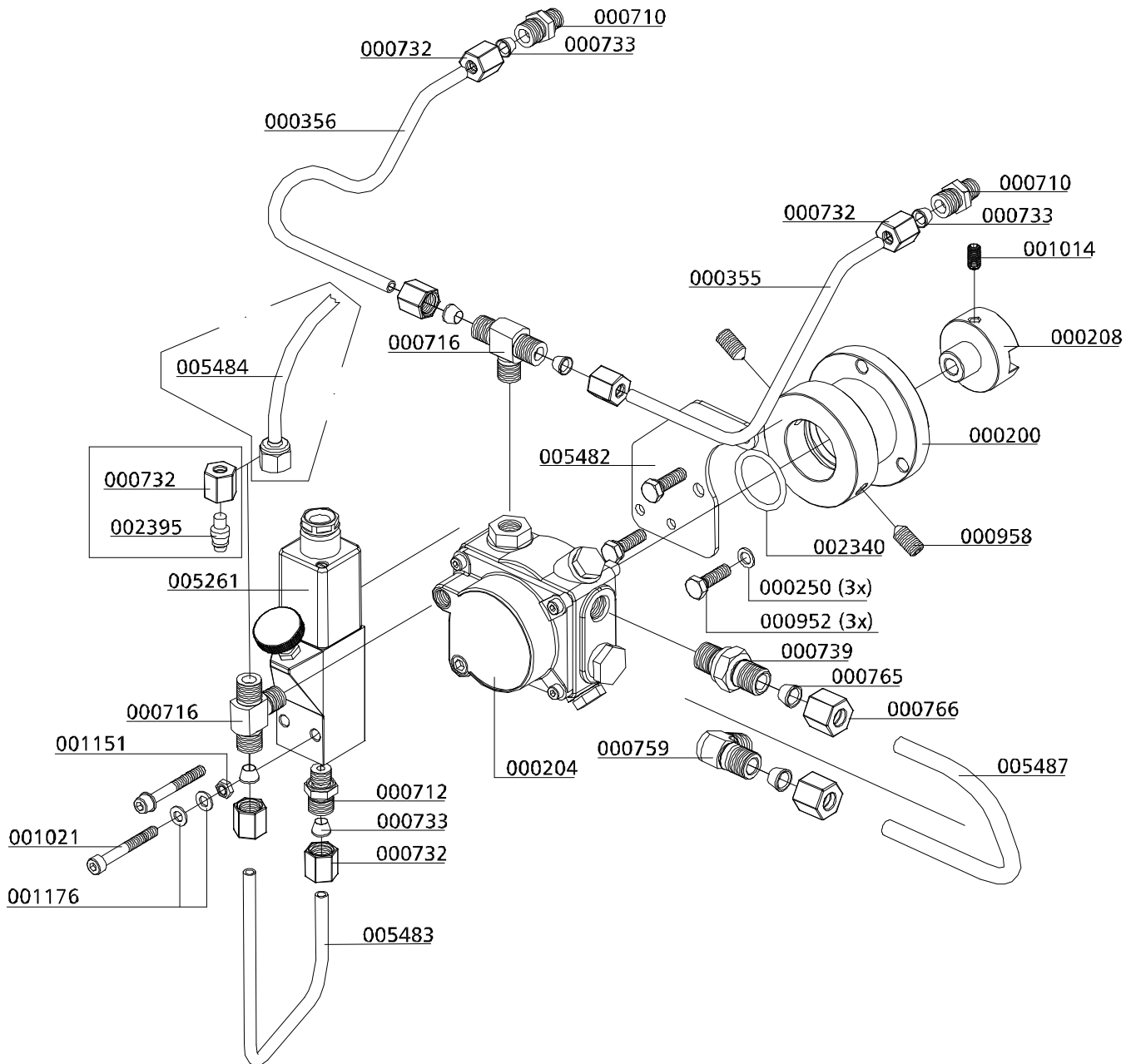

C



ERSATZTEILLISTE / SPARE PART LIST

Baugruppe: Ansaugfilter / Intake Filter

Best.-Nr. / Order No.	Benennung	Description
000170	Ansaugfilterpatrone	Air Intake Filter Cartridge
000171	Ansaugfiltergehäuse inkl. Patrone, kompl	Int. Filter Housing c/w filter
000229	Einschraubadapter Ansaugfilter	Adapter Inlet Filter Housing

C

DETAILANSICHT / DETAILED VIEW

Baugruppe: Ansaugfilter / Intake Filter

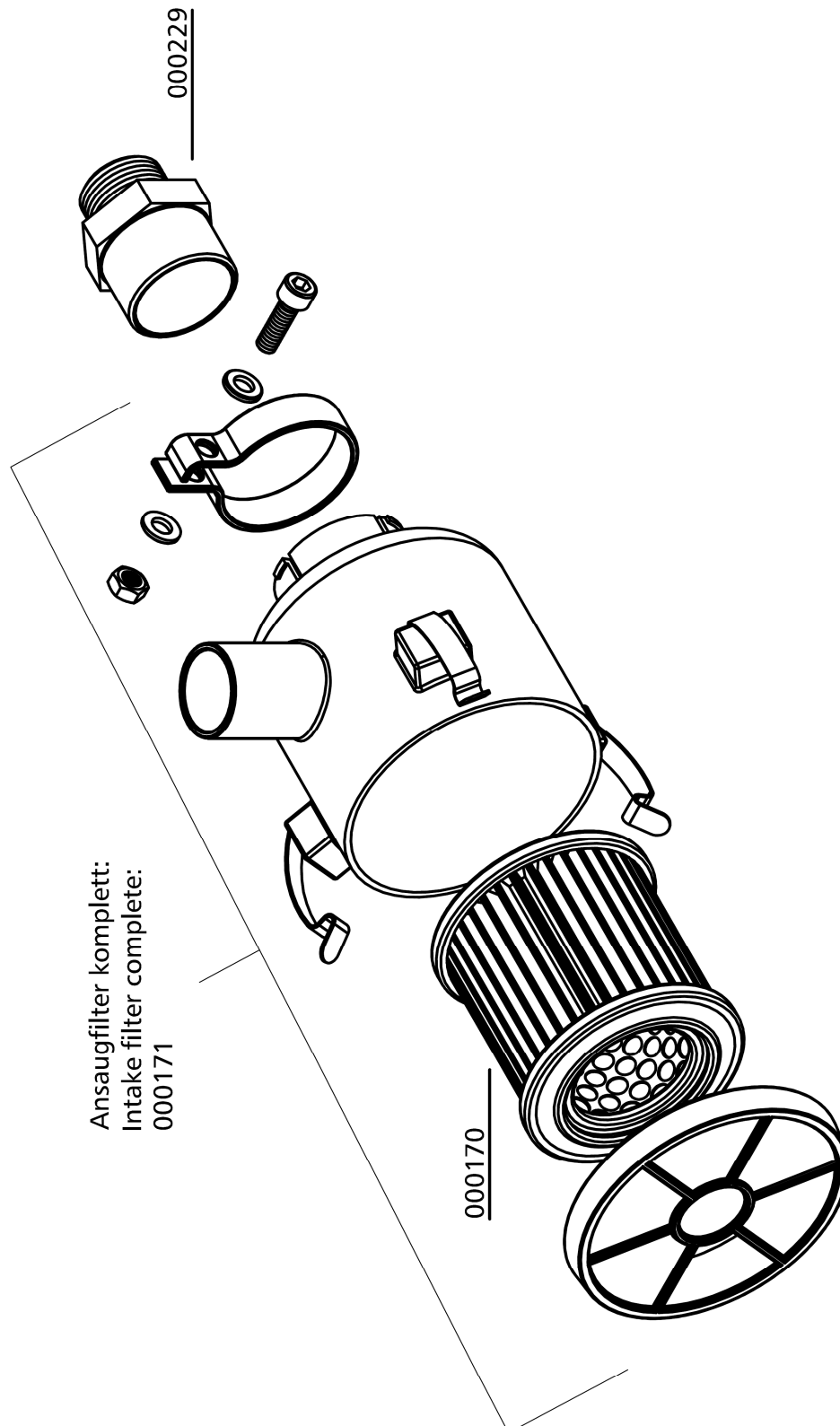

C



ERSATZTEILLISTE / SPARE PART LIST

Kühler 1. Stufe / Cooler 1st Stage

Best.-Nr. / Order No.	Benennung	Description
000320	Gerade Verschraubung, GE1/2" - 18L	Straight Connection, GE1/2" - 18L
000861	Schneidring, PSR 18LX	Olive Seal, PSR 18LX
000862	Mutter 18L	Union Nut 18L
000866	Verschraubung, GE18LRFCX	Connection, GE18LRFCX
000867	Verschraubung mit fester Mutter, EW18LOMDCF	Elbow Connection with fixed nut, EW18LOMDCF
001100	Sechskant Schraube, M10x25mm DIN933 8.8 ZN	Hexagon Screw, M10x25mm DIN933 8.8 ZN
001186	U-Scheibe, A10 DIN125 ZN	Washer, A10 DIN125 ZN
001190	Federring, A10 DIN127 ZN	Spring Washer, A10 DIN127 ZN
002013	Kühler 1. Stufe, Al	Cooler 1st Stage, Alloy

C

DETAILANSICHT / DETAILED VIEW

Kühler 1. Stufe / Cooler 1st Stage

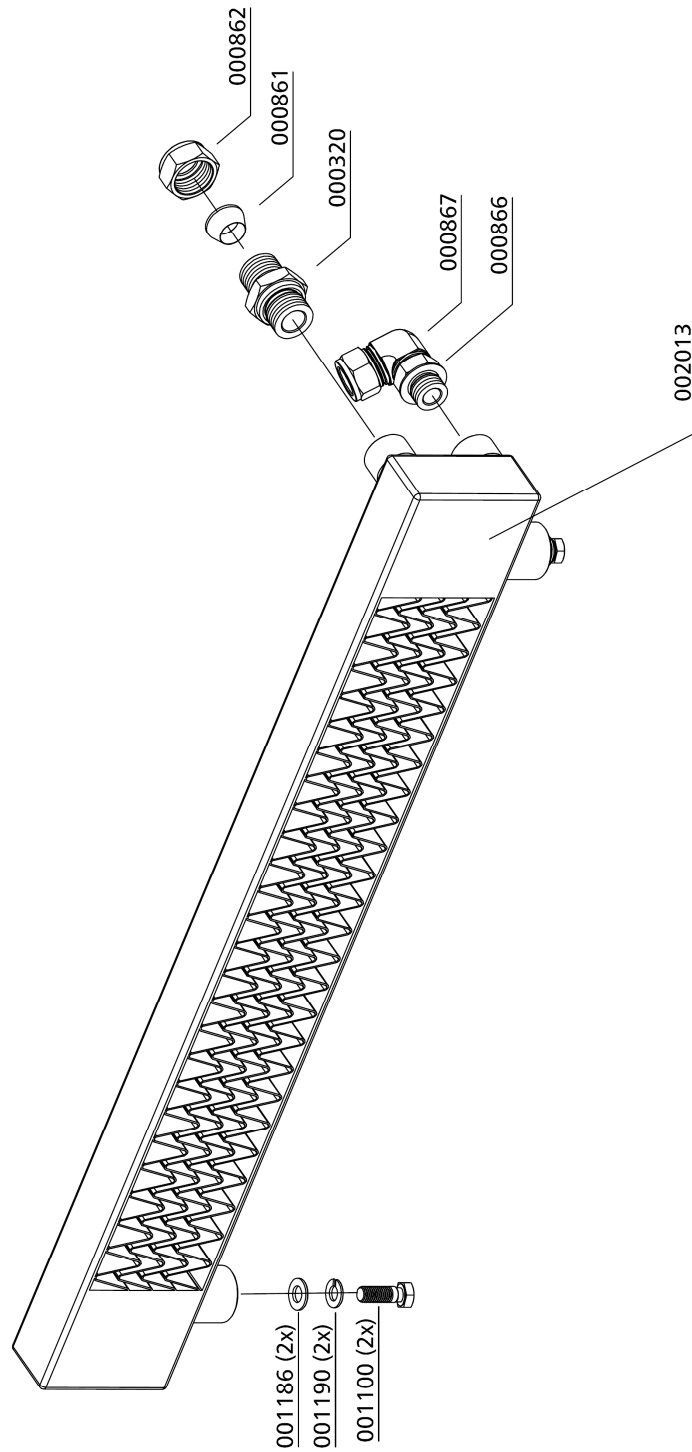



ERSATZTEILLISTE / SPARE PART LIST

Kühler 2. Stufe / Cooler 2nd Stage

Best.-Nr. / Order No.	Benennung	Description
000331	Halter	Bracket
000332	Wärmetauscher inkl. Mutter u. Schneidring	Heat Exchanger 2nd Stage c/w Nut and Olive Seal
000333	Halter	Bracket
000334	PVC Schlauch, transparent, l=320mm	PVC Hose for Bracket
001058	Zylinderschraube M8x70 DIN 912 8.8 ZN	Allen Screw M8x70 DIN 912 8.8 ZN
001100	Sechskantschraube M10x25 DIN 933 8.8 ZN	Hexagon Screw M10x25 DIN 933 8.8 ZN
001159	Stopfmutter M8 DIN 985 ZN	Lock Nut M8 DIN 985 ZN
001181	U-Scheibe A8	Washer A8
001323	Cu-Ring DIN 7603 A	Copper Seal Ring DIN 7603 A

C

DETAILANSICHT / DETAILED VIEW

Kühler 2. Stufe / Cooler 2nd Stage

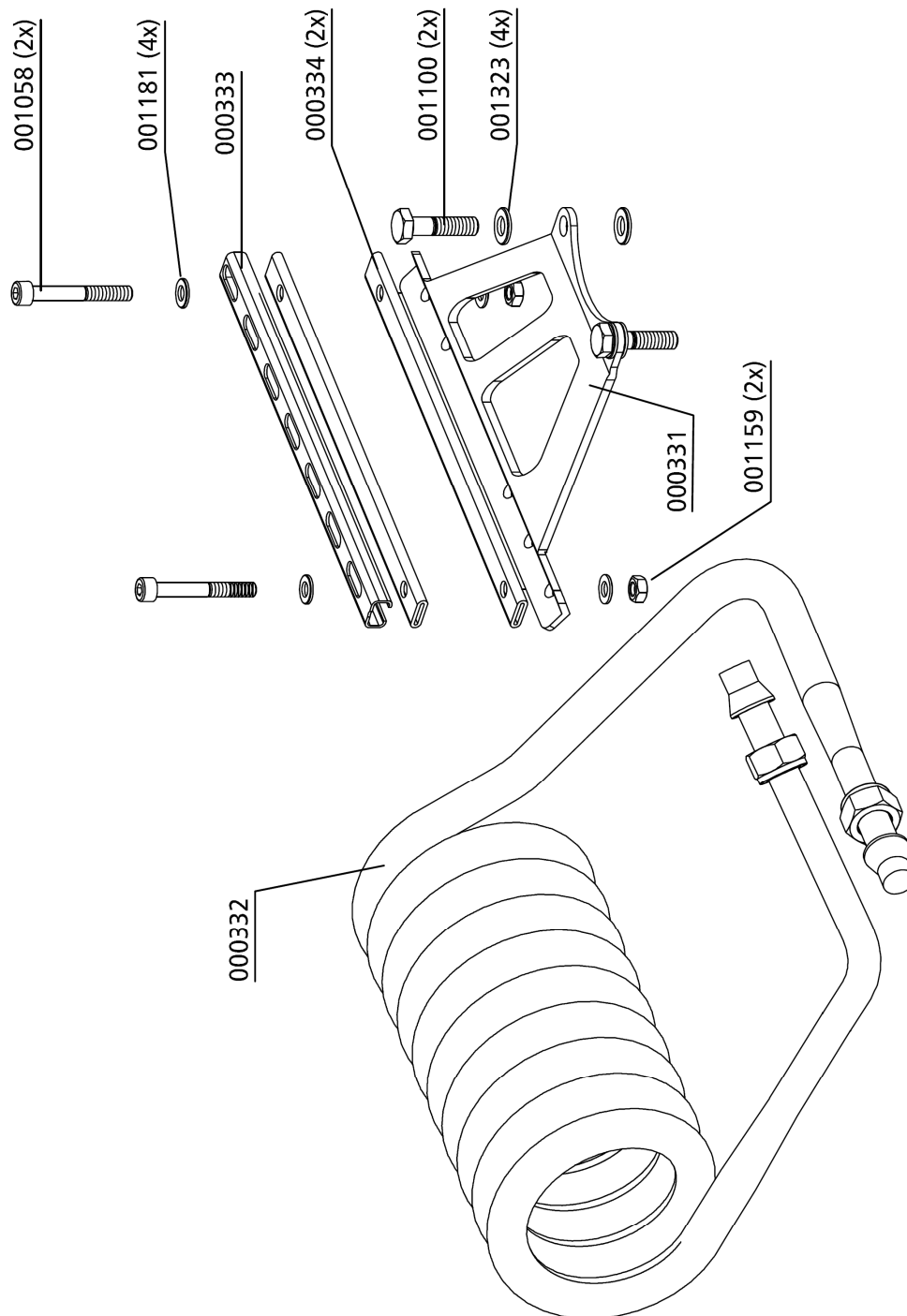

C



ERSATZTEILLISTE / SPARE PART LIST

Kühler 3. & 4. Stufe / Cooler 3rd & 4th Stage

Best.-Nr. / Order No.	Benennung	Description
000209	Öleinfüllstopfen	Oil Filler Plug
000312	Halter mit Blindnietmuttern	Bracket c/w Blind Rived Nuts
000313	Halter mit Blindnietmuttern	Bracket c/w Blind Rived Nuts
000314	Halteblech Ölschlauch	Bracket Oil House
000315	Kühlrohr links 4.Stufe ohne Halter u. Klemmen	Cooling Pipe 4th w/o Holder&Clamp and Olive Seal
000316	Kühlrohr links 3.Stufe ohne Halter u. Klemmen	Cooling Pipe 3rd w/o Holder&Clamp and Olive Seal
000509	Zylinderschraube M6 x 35 DIN 912	Allen Bolt M6 x 35 DIN 912
000629	Doppelschelle 2 x 8mm 1 Paar, PVC schwarz	Pipe Clamp 2x8mm - 1 pair, PVC black
000638	Doppelschelle 2 x 8 mm 1 Paar, Alu	Pipe Clamp 2x8mm 1pair, Alloy
000735	Verschraubung G08PL	Connection G08P
001013	Zylinderschraube M6x45mm DIN912 8.8 ZN	Allen Bolt M6x45mm DIN912 8.8 ZN
001029	Zylinderschraube M6x20mm DIN912 8.8 ZN	Allen Bolt M6x20mm DIN912 8.8 ZN
001178	U-Scheibe A6 DIN902 ZN	Washer A6 DIN902 ZN
002358	Schnellkupplung gerade	Quick rel. coupling, straight
005134	PG Verschraubung PG29 kompl. m. Klemmmutter	PG Connection PG29 c/w Nut

DETAILANSICHT / DETAILED VIEW

Kühler 3. & 4. Stufe / Cooler 3rd & 4th Stage

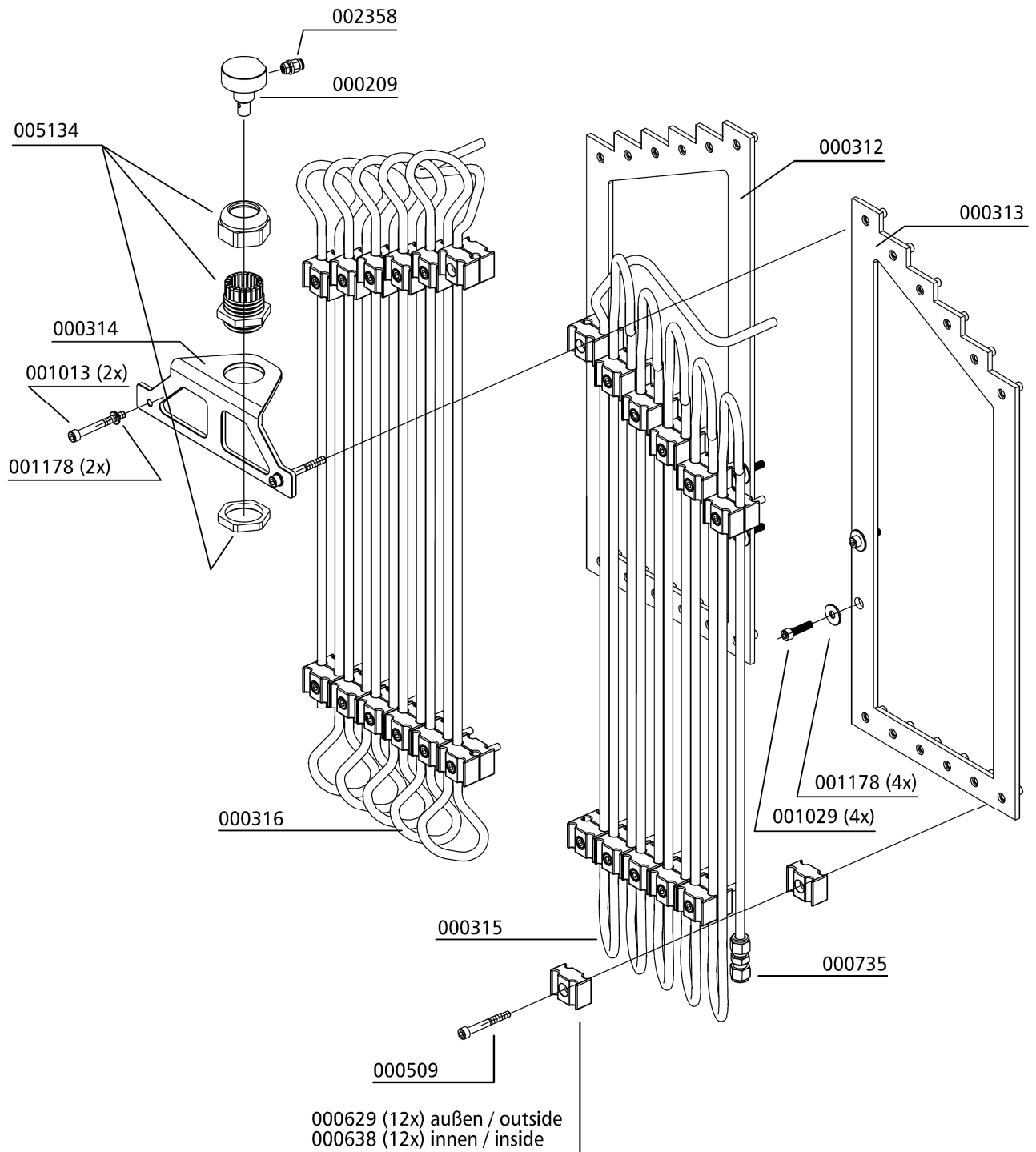

C



ERSATZTEILLISTE / SPARE PART LIST

Öl- / Wasserabscheider 1. Stufe / Oil- / Water Separator 1st Stage

Best.-Nr. / Order No.	Benennung	Description
000172	Prallscheibe	Mounting plate water separator
000173	Sinterfilter Wasserabscheider	Sintered Filter Water separat.
000174	Drallscheibe, Wasserabscheider	Twist Disk, Water separator
000176	Stiftschraube, Wasserabscheider 2. Stufe	Treaded Stud
000177	Trichter f. Wasserabscheider	Water Deflector
000220	Sicherheitsventil G3/8"	Safety Valve G3/8" 8 bar
000379	Wasserabscheider - Oberteil G1/2" IG	Top Water Separator 1/2"female
000391	U-Sit Ring	Seal Ring U-Sit
000562	Wasserabscheider - Ring	Ring Water Separator, 2nd St.
000564	Wasserabscheider-Behälter	Container Water Separ.
000820	Verschraubung	Elbow-Connection
000837	Verschlussstopfen	Plug
000838	Verschlussstopfen	Plug
000863	Winkelverschraubung 90°	Elbow Connection
001132	6-kant Schraube	Hexagon Screw
001156	Stopfmutter	Lock Nut M6
001191	U-Scheibe A12	Washer A12
001192	Federring A12	Spring Washer A12
001272	O-Ring	O-Ring Water separator
003077	Entwässerungsventil G1/4" AG, konisch	Drain Valve G1/4" male

C

DETAILANSICHT / DETAILED VIEW

Öl- / Wasserabscheider 1. Stufe / Oil- / Water Separator 1st Stage

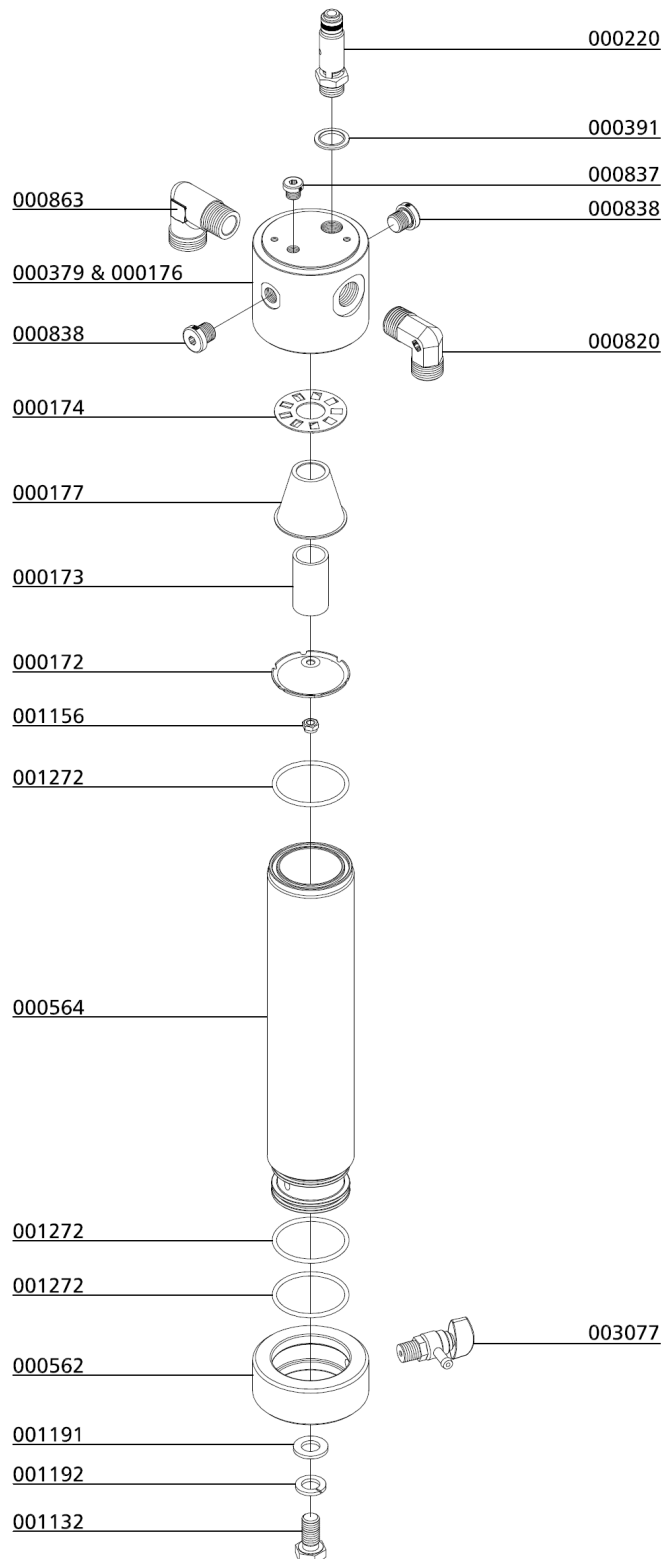

C



ERSATZTEILLISTE / SPARE PART LIST

Öl- / Wasserabscheider 2. Stufe / Oil- / Water Separator 2nd Stage

Best.-Nr. / Order No.	Benennung	Description
000172	Prallscheibe	Mounting plate water separator
000173	Sinterfilter Wasserabscheider	Sintered Filter Water separat.
000174	Drallscheibe, Wasserabscheider	Twist Disk, Water separator
000176	Stiftschraube, Wasserabscheider 2. Stufe	Treaded Stud
000177	Trichter f. Wasserabscheider	Water Deflector
000379	Wasserabscheider - Oberteil G1/2" IG	Top Water Separator 1/2"female
000380	Sicherheitsventil G3/8"	Safety Valve G3/8" 22 bar
000391	U-Sit Ring	Seal Ring U-Sit
000562	Wasserabscheider - Ring	Ring Water Separator, 2nd St.
000564	Wasserabscheider-Behälter	Container Water Separ.
000761	Winkelverschraubung	Elbow Connection
000837	Verschlussstopfen	Plug
000838	Verschlussstopfen	Plug
000866	Verschraubung	Connection
000921	Reduzierung	Reducer
001132	6-kant Schraube	Hexagon Screw
001156	Stopfmutter	Lock Nut M6
001191	U-Scheibe A12	Washer A12
001192	Federring A12	Spring Washer A12
001272	O-Ring	O-Ring Water separator
003077	Entwässerungsventil G1/4" AG, konisch	Drain Valve G1/4" male

C

DETAILANSICHT / DETAILED VIEW

Öl- / Wasserabscheider 2. Stufe / Oil- / Water Separator 2nd Stage

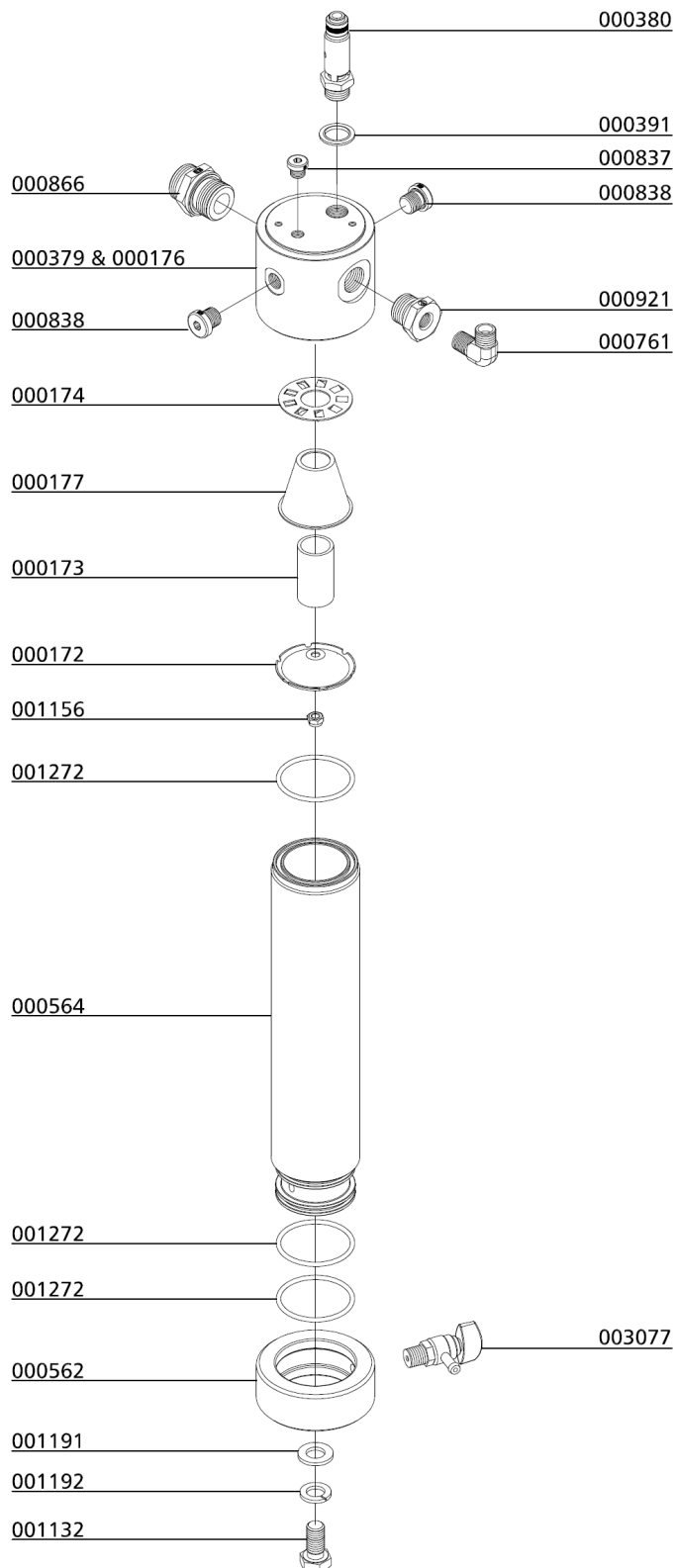

C



ERSATZTEILLISTE / SPARE PART LIST

Öl- / Wasserabscheider 3. Stufe / Oil- / Water Separator 3rd Stage

Best.-Nr. / Order No.	Benennung	Description
000147	Halteklötz Sicherheitsventil G3/8"	Mounting Base SV G3/8" female
000172	Prallscheibe	Mounting plate water separator
000173	Sinterfilter Wasserabscheider	Sintered Filter Water separat.
000176	Stiftschraube, Wasserabscheider 2. Stufe	Treaded Stud
000177	Trichter f. Wasserabscheider	Water Deflector
000379	Wasserabscheider - Oberteil G1/2" IG	Top Water Separator 1/2"female
000381	Sicherheitsventil G3/8"	Safety Valve G3/8" 90 bar
000391	U-Sit Ring	Seal Ring U-Sit
000562	Wasserabscheider - Ring	Ring Water Separator, 2nd St.
000564	Wasserabscheider-Behälter	Container Water Separ.
000761	Winkelverschraubung	Elbow Connection
000837	Verschlussstopfen	Plug
000838	Verschlussstopfen	Plug
000921	Reduzierung	Reducer
001132	6-kant Schraube	Hexagon Screw
001156	Stopfmutter	Lock Nut M6
001191	U-Scheibe A12	Washer A12
001192	Federring A12	Spring Washer A12
001272	O-Ring	O-Ring Water separator
003077	Entwässerungsventil G1/4" AG, konisch	Drain Valve G1/4" male

C

DETAILANSICHT / DETAILED VIEW

Öl- / Wasserabscheider 3. Stufe / Oil- / Water Separator 3rd Stage

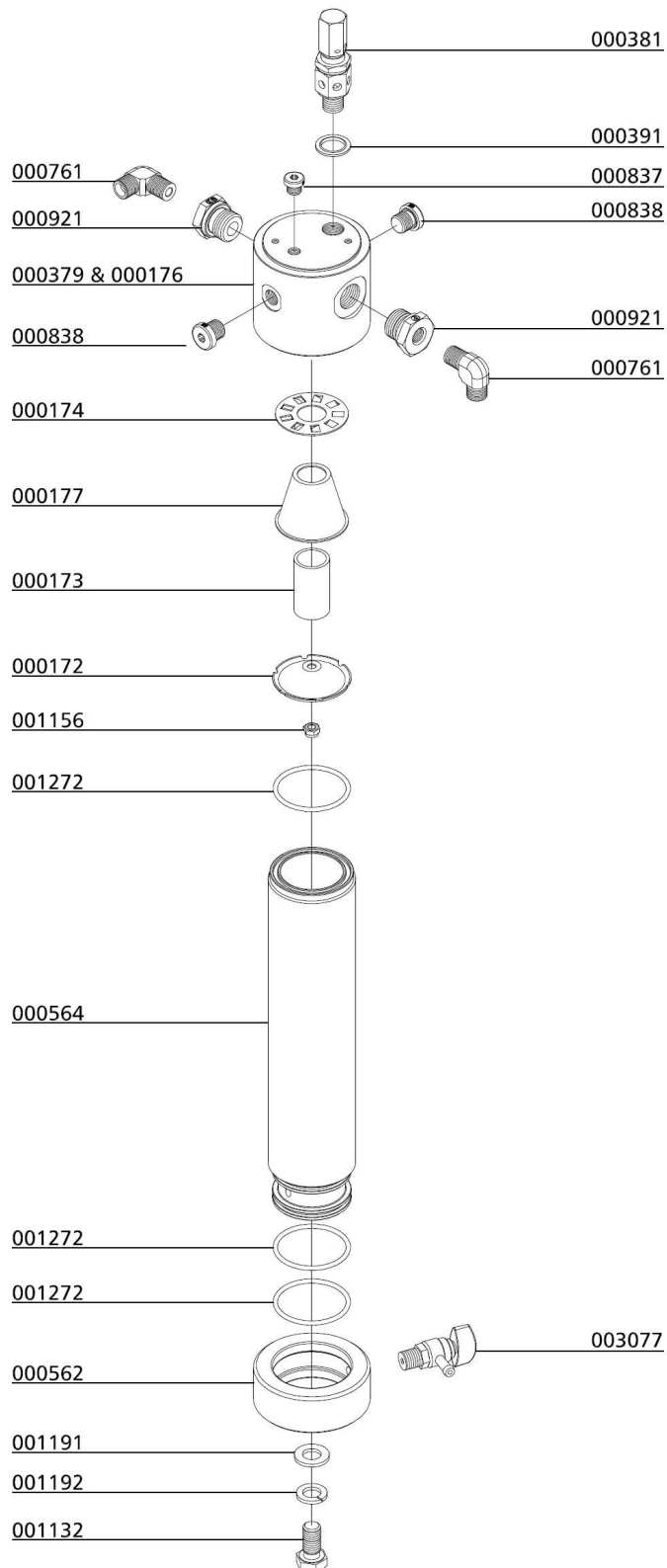

C



ERSATZTEILLISTE / SPARE PART LIST

Filtergehäuse 1,7 l / Filter Housing 1.7 ltr

Best.-Nr. / Order No.	Benennung	Description
000002	Filterpatrone 1,7 Liter	Filter Cartridge 1.7 ltr BA
000272	Abstandshalter für Filtergehäuse	Spacer Bracket for Filtertower
000383	Messing Adapter für Filterpatrone	Brass Filter Adapter
000384	Düse für Filtergehäuse	Jet Filter Housing
000738	Verschraubung	Connection
000761	Winkelverschraubung	Elbow Connection
001159	Stopfmutter	Lock Nut M8
001181	U-Scheibe A8	Washer A8
001285	Stützring, Filtergehäuse	Back-up Ring Filter Housing
001287	O-Ring, Filtergehäuse	O-Ring filter housing
001459	Filterpatrone	Filter Cartridge
002140	Filterschlüssel 1,7 & 2,3 Liter Behälter	Filter tool 1,7 & 2,3 Litre
002148	Haltebügel für Filtergehäuse	U-Clamp Filter Housing
002366	Filtergehäuse, kompl.	Filter housing 1,7 ltr.
003077	Entwässerungsventil G1/4" AG, konisch	Drain Valve G1/4" male

C

DETAILANSICHT / DETAILED VIEW

Filtergehäuse 1,7 l / Filter Housing 1.7 ltr

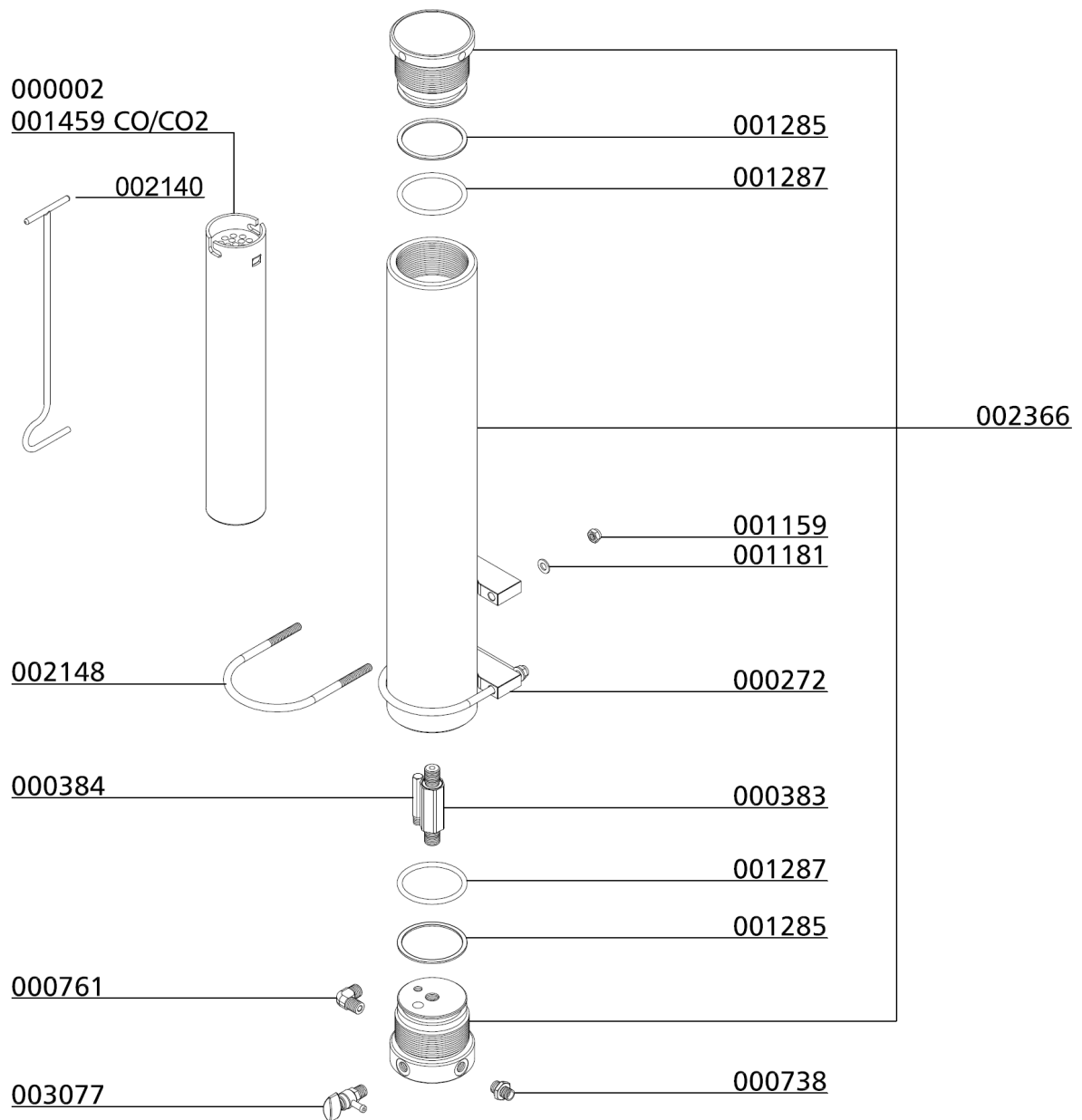

C



ERSATZTEILLISTE / SPARE PART LIST

Druckhalteventil / Pressure Maintaining Valve

Best.-Nr. / Order No.	Benennung	Description
000169	Druckhalterückschlagventil, schwarz	Pressure Maint. Valve black
000498	U-Scheibe DIN 125 A6	Washer DIN 125 A6
000506	Feder	Spring
000508	USIT Ring 13,7 x Ø20 x 1,5	Gasket Ring U-Sit 13,7 x Ø20 x 1,5
000511	Mutter, Druckhalterückschlagventil	Lock Nut PMV
000512	Schraube, Druckhalte-Rückschlagventil	Set Bolt PMV
000513	Druckstück für Druckhalteventil,	Spring Adapter PMV, spring adapter
000514	Stift Druckhalte-/Rückschlagventil	Stud PMV
000515	Gehäuse, Druckhalte-Rückschlagventil	Main Body PMV
000516	Nutring, Druckhalterückschlagventil 5 x 10 x 5/2,5 90° Blau	Seal Ring PMV 5 x 10 x 5/2,5 90° blue
000517	Feder, Druckhalterückschlagventil	Coil Spring PMV
000518	Unterlegscheibe, Messing	Washer, Brass
000519	Dichtkappe, Druckhalte Rückschlagventil, schwarz	Plastic Seal Piston PMV, black
000520	Hohlschraube, DHRV	Inlet Jet PMV
000765	Schneidring PSR 08 LX	Olive Seal PSR 08 LX
000767	Mutter 08 S	Union Nut 08 S
001023	Zylinderschraube	Allen Bolt

DETAILANSICHT / DETAILED VIEW

Druckhalteventil / Pressure Maintaining Valve

**Reparatursatz
003548:**

Bestehend aus:
Gelbmarkierte
Bestellnummern

**Repair kit
003548:**

Consists of:
Yellow marked
P/N's

000169 (complete)

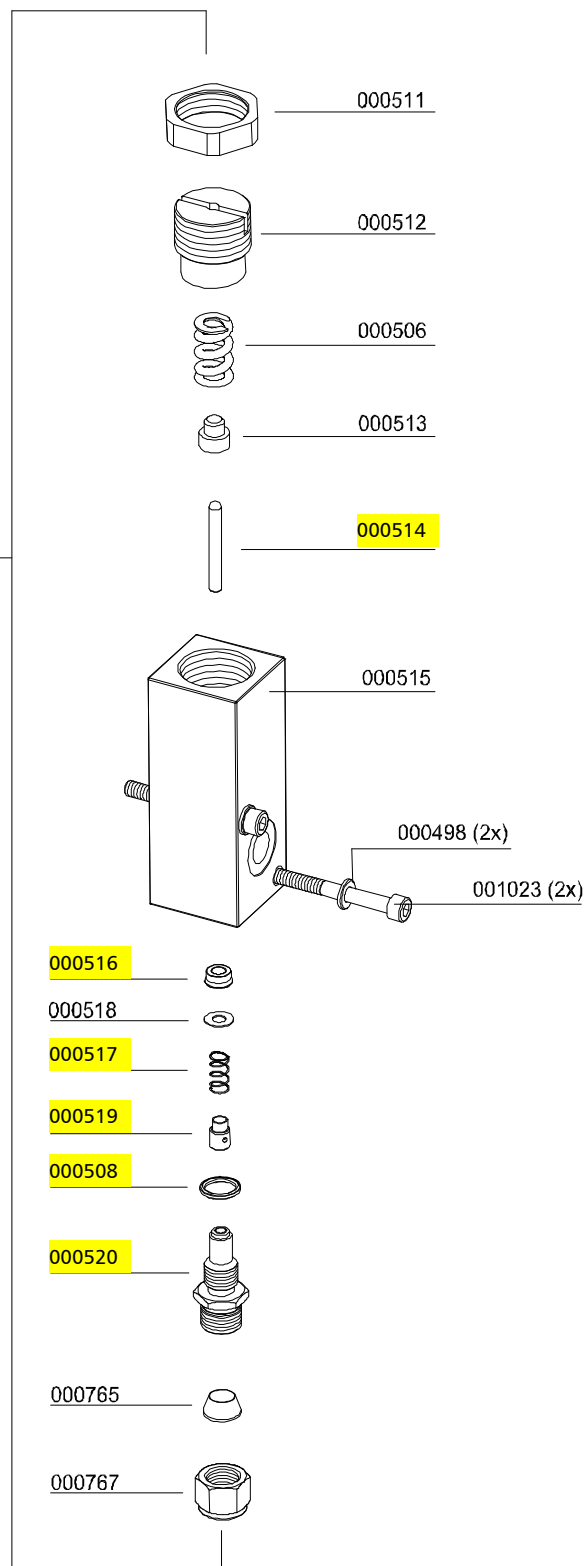

C

Sicherheitsventil / Safety Valve

Best.-Nr. / Order No.	Benennung	Description
000233	Sockel für Sicherheitsventil mit TÜV, x G1/4" seitlich 180°	Base for Safety Valve TÜV type
000553	Sicherheitsventil 225bar mit TÜV	Safety Valve 225bar c/w TÜV
000554	Sicherheitsventil 250bar mit TÜV	Safety Valve 250bar c/w TÜV
000555	Sicherheitsventil 300bar mit TÜV	Safety Valve 300bar c/w TÜV
000556	Sicherheitsventil 330bar mit TÜV	Safety Valve 330bar c/w TÜV
000557	Sicherheitsventil 350bar mit TÜV	Safety Valve 350bar c/w TÜV
000738	Verschraubung GE08LRCFX	Connection GE08LRCFX
000765	Schneidring PSR 08 LX	Olive Seal PSR 08 LX
000766	Mutter M08LCFX	Nut M08LCFX
000838	Verschlussstopfen VSTIR1/4EDCF	Plug VSTIR1/4EDCF
001044	Zylinderschraube	Allen Bolt
001058	Zylinderschraube	Allen Bolt
001158	Mutter	Nut
001181	U-Scheibe	Washer
001244	O-Ring, Flansch Sicherheitsventil	O-Ring, Flange Safety Valve
001814	Sicherheitsventil 225bar mit CE	Safety Valve 225bar with CE
001815	Sicherheitsventil 250bar mit CE	Safety Valve 250bar with CE
001816	Sicherheitsventil 330bar mit CE	Safety Valve 330bar with CE
001817	Sicherheitsventil 350bar mit CE	Safety Valve 350bar with CE

DETAILANSICHT / DETAILED VIEW

Sicherheitsventil / Safety Valve

Druck/ Pressure	SV-Ventil mit CE-Prüfung/ Safety Valve with CE	SV-Ventil mit TÜV-Prüfung/ Safety Valve with TÜV
225 bar	001814	000553
250 bar	001815	000554
285/300 bar	-----	000555
330 bar	001816	000556
350 bar	001817	000557

Sonder-Einstelldrücke auf Anfrage! /
Special relieve pressures are available on request!

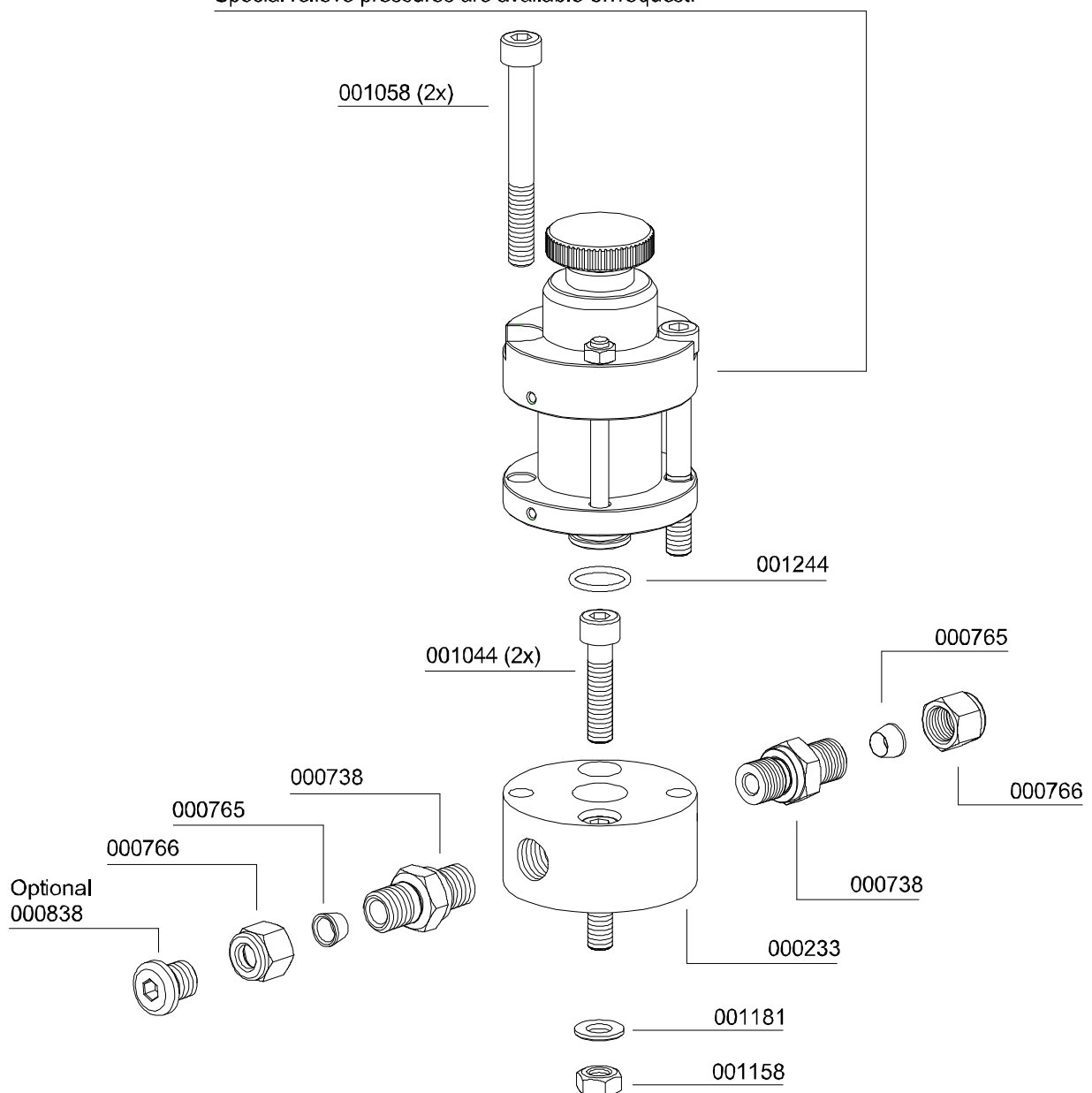



ERSATZTEILLISTE / SPARE PART LIST

Motor / Motor

Best.-Nr. / Order No.	Benennung	Description
000620	Keilriemenscheibe inkl. Spannbuchse, TBA118-2 1610-38, 50Hz	Pulley & Boss Kit, TBA118-2 1610-38, 50Hz
001129	Schlossschraube, M12x40mm DIN603 8.8 ZN	Carriage Bolt, M12x40mm DIN603 8.8 ZN
001165	Mutter, M12 DIN934 ZN	Nut M12, M12 DIN934 ZN
001191	U-Scheibe, A12 DIN125 ZN	Washer, A12 DIN125 ZN
001192	Federring, A12 DIN 127 ZN	Spring Washer, A12 DIN 127 ZN
001211	Passfeder, A10X8X56mm	Woodruff Key, A10X8X56mm
001413	Keilriemen, XPA 1757, 50 Hz	V-Belt, XPA 1757, 50 Hz
002878	Keilriemen, XPA 1732, 60 Hz	V-Belt, XPA 1732, 60 Hz
003924	Keilriemenscheibe inkl. Spannbuchse, SPA100-2 TB 1610-38, 60Hertz	Pulley & Boss Kit, SPA100-2 TB 1610-38, 60Hertz
005906	Antriebsmotor 15 kW	Drive Motor

C

DETAILANSICHT / DETAILED VIEW

Motor / Motor

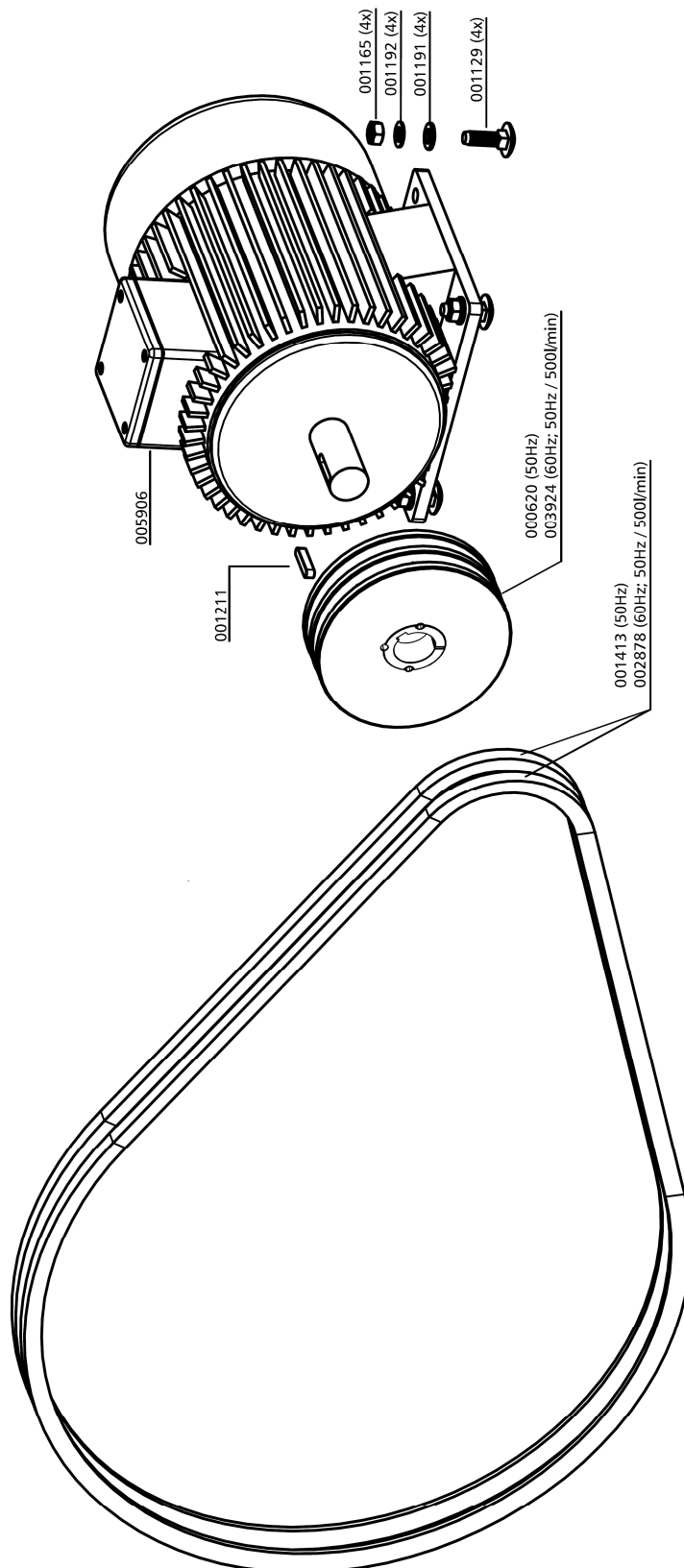

C



ERSATZTEILLISTE / SPARE PART LIST

Lüfterrad / Cooling Fan

Best.-Nr. / Order No.	Benennung	Description
000317	Schwungscheibe	Flywheel
000318	Zentrierring, Lüfterblätter	Fixing Ring Fan Blades
000498	U-Scheibe A6	Washer A6
001030	Zylinderschraube, M6x16mm DIN912 8.8 ZN	Allen Bolt, M6x16mm DIN912 8.8 ZN
002335	Ventilatorflügelblatt, schwarz	Fan Blade, black, new version

C

DETAILANSICHT / DETAILED VIEW

Lüfterrad / Cooling Fan

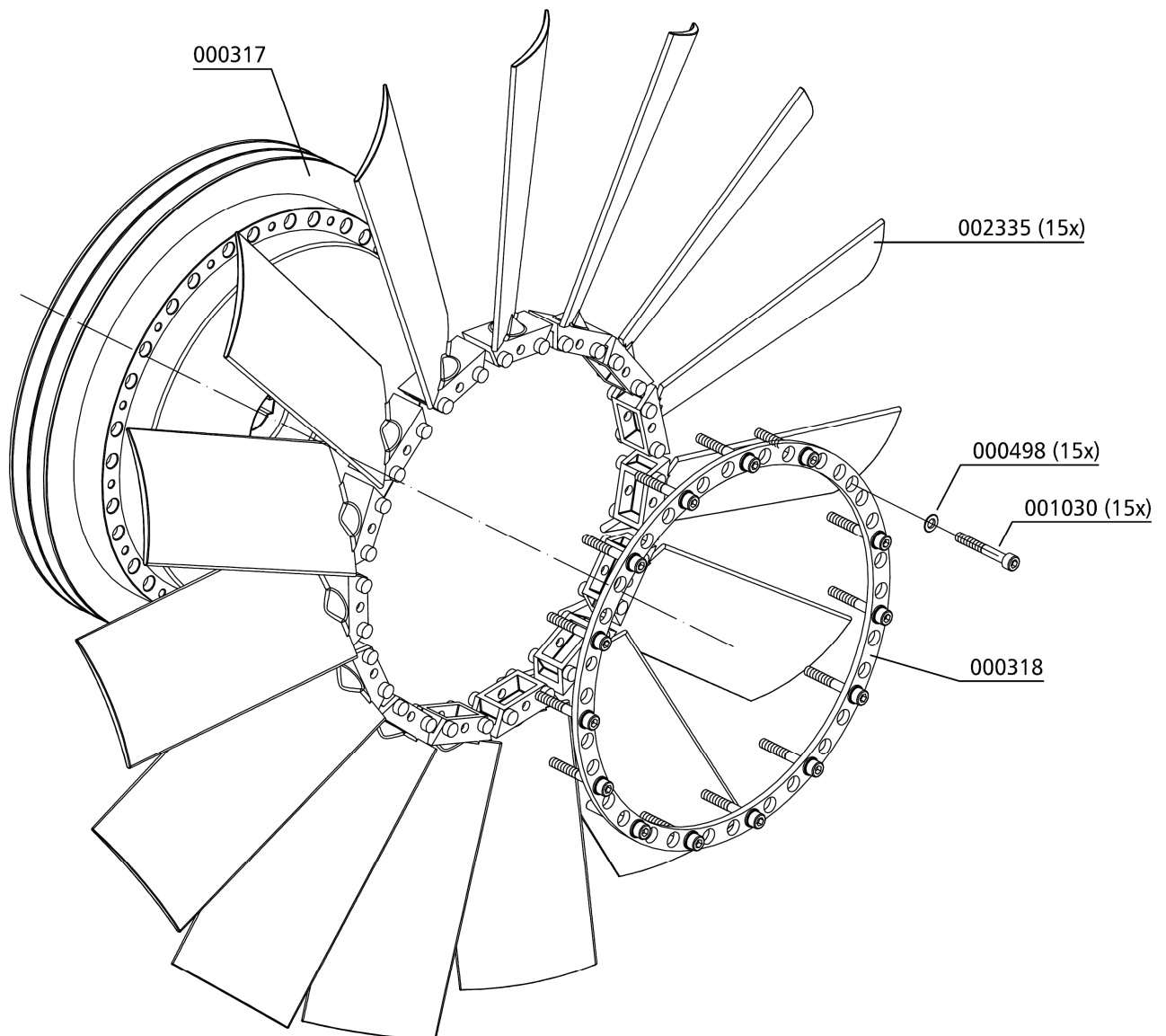

C



ERSATZTEILLISTE / SPARE PART LIST

Baugruppe: Ölablassschlauch / Assembly: Oil Drainage Tube

Best.-Nr. / Order No.	Benennung	Description
000817	Verschraubung, GE15LR3/8CFX	Connection, GE15LR3/8CFX
001005	Zylinderschraube, M5x16mm DIN912 8.8 ZN	Allen Screw, M5x16mm DIN912 8.8 ZN
001176	U-Scheibe A5, A5 DIN125 ZN	Washer A5, A5 DIN125 ZN
001527	Klemmhalter für Oelsablassschlauch	Oil Drain Hose Clamp
001548	Kugelhahn (Ölablassschlauch)	Ball Valve (Oil Drain Hose)
002153	Ölablassschlauch mit Kugelhahn	Oil Drain Hose c/w Ball Valve
006417	Ölablassschlauch	Oil Drain Hose

C

DETAILANSICHT / DETAILED VIEW

Baugruppe: Ölablassschlauch / Assembly: Oil Drainage Tube

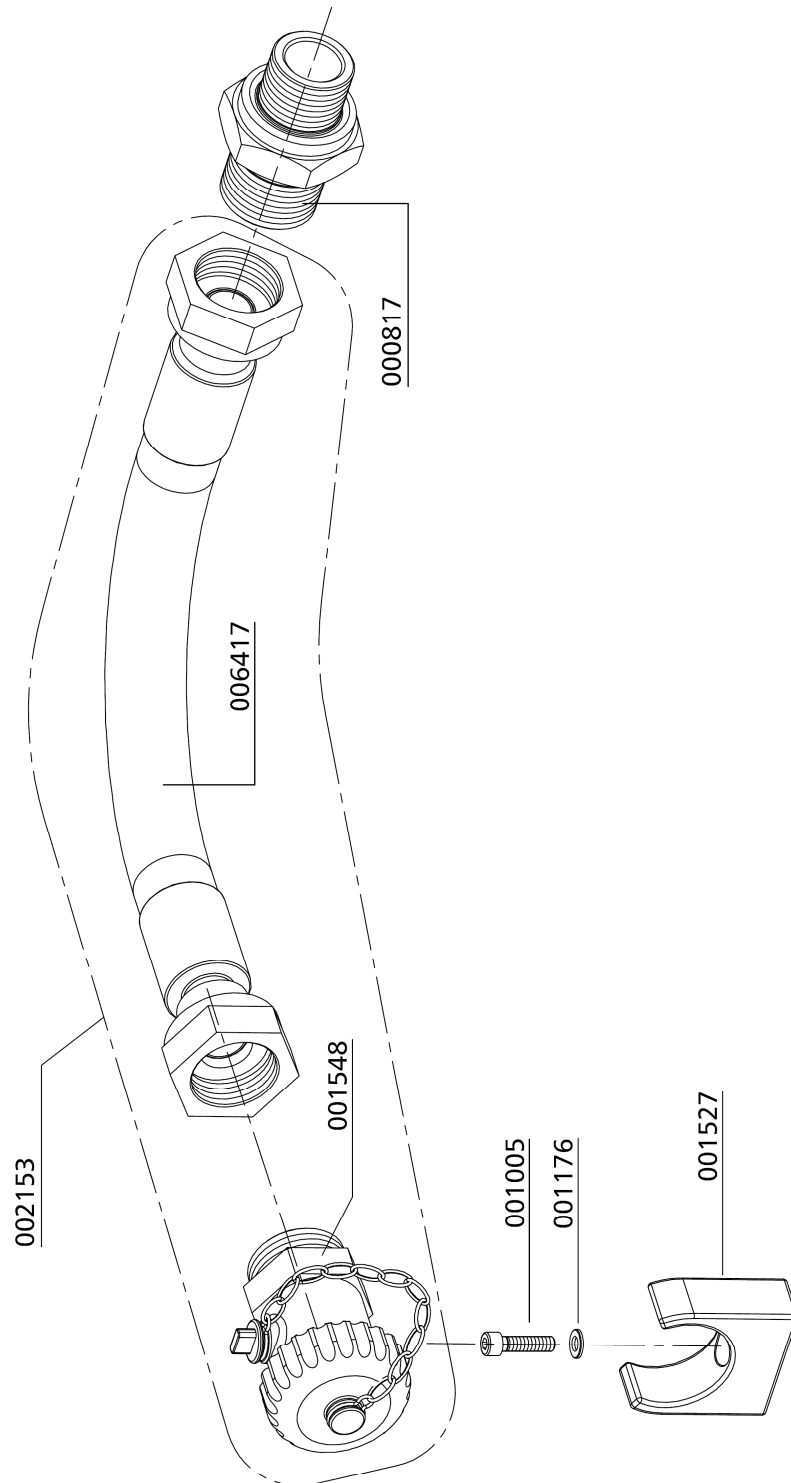

C

ERSATZTEILLISTE / SPARE PART LIST

Füllschlauch / Filling Hose

Best.-Nr. / Order No.	Benennung	Description
009503	Hochdruckschlauch 10L, 1500 mm, drehbar	HP-Hose 10L 1500 mm, rotatable

009503

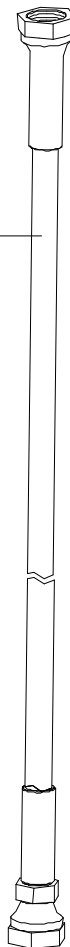

BG : Füllventil
Ass: Filling Valve

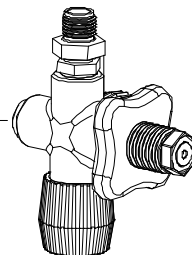

C



ERSATZTEILLISTE / SPARE PART LIST

Kreuzventil / Cross Design Valve

Best.-Nr. / Order No.	Benennung	Description
000213	Handrad, schwarz DIN	Hand Wheel, black
000215	Handrad rot DIN	Hand Wheel, red
000386	Gleitscheibe, Kreuzventil	Slide Washer
000387	Feder (Kreuzventil)	Coil Spring, cross d. valve
000696	Füllanschluss o. Handrad 200bar	Filling Connect. w/o handwheel 200bar
000698	Füllanschluss o. Handrad 300bar	Filling Conne. w/o handwheel 300bar
000709	Füllventil Kreuzbauweise	Filling Valve cross design
000838	Verschlussstopfen	Plug
001237	O-Ring DIN Flaschenanschluss	O-Ring DIN filling connector
001391	O-Ring	O-Ring
001392	Füllhandrad Kreuzventil	Hand Wheel Filling Valve cross
001393	Entlüftungsspindel	Vent Spindle
001394	Entlüftungshandrad	Vent Hand Wheel
001395	Gleitscheibe, schwarz, Kreuzventil	Slide Washer, plastic black
001397	Kupferdichtung	Copper Seal Ring
001398	Madenschraube	Worm Screw
001399	Oberspindel	Adapter Shaft
001400	Dichtspindel, Kreuzventil	Seal Spindle Filling Valve
001401	Schlitzmutter	Slotted Nut
001402	Gehäuseverschraubung kompl. m. O-Ringen	Filling Spindle Body
002812	Verschraubung, Edelstahl	Connection, S/S
003684	Füllventil Kreuzbauweise 200 bar	Filling Valve cross design 200 bar
003685	Füllventil Kreuzbauweise 300 bar	Filling Valve cross design 300 bar

C

DETAILANSICHT / DETAILED VIEW

Baugruppe: Füllventil / Assembly: Filling valve

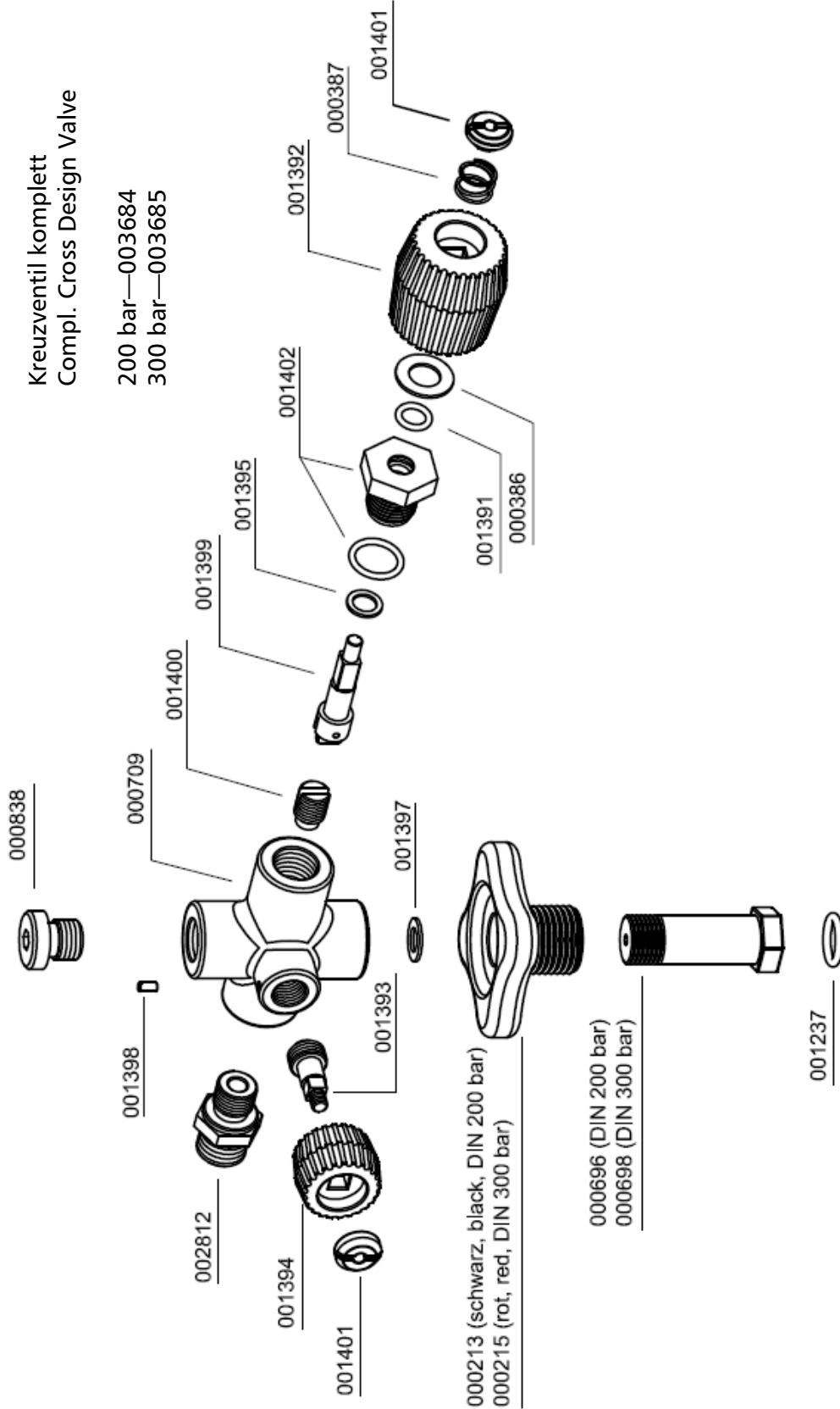

Kreuzventil komplett
 Compl. Cross Design Valve

200 bar—003684
 300 bar—003685

C



OPTIONS



Table of Contents

Auto Shut Down.....	2
Automatic Condensation Drain.....	7
Auto Start Function.....	18
Oil Pressure Gauge	24
Oil Pressure Monitoring	27
Oil Temperature Monitoring	34
Cylinder Head Temperature Monitoring	37
Interstage Pressure Gauges.....	40
Version with 0.8 ltr final filter separator.....	43
Version with 2.3 ltr final filter separator.....	49
200+300bar Parallel Filling Pressure Operation.....	57
Air Cooler Connection Kit.....	64
Phase Monitoring.....	67
Condensate Tank 60L	71



AUTO SHUT DOWN

D

AUTO SHUT DOWN

Final pressure switch

The pressure switch shuts off the compressor automatically when the selected final pressure is reached. The final pressure switch is already adjusted to the corresponding cut-out pressure.

The pressure can be adjusted with the upper adjusting screw as follows:

Increasing cut-out pressure:

Turn the adjusting screw clockwise

Reducing cut-out pressure:

Turn the adjusting screw anti-clockwise

Adjust the pressure switch in steps of a quarter turn.

Restart the compressor after every adjustment step to verify the actual cut-out pressure.

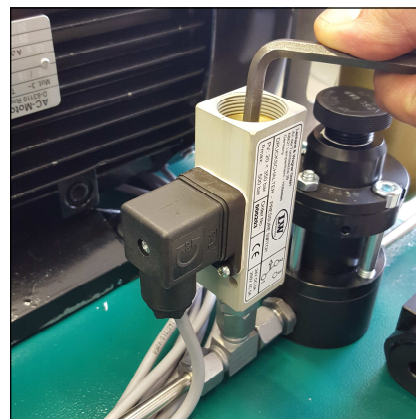

Final pressure switch

D

Note

Do not adjust the final pressure switch to the safety valve pressure. The final pressure switch has to be adjusted to min. 10 bar below the safety valve pressure. Otherwise, the safety valve can open during operation. This considerably reduces the life of the safety valve.

Example settings:

Safety valve	Max. Operating Pressure
225 bar	215 bar
250 bar	240 bar
330 bar	320 bar

AUTO SHUT DOWN

Safety valve test



Note

Do not fill any tank during test phase!

Safety valve test as follows:

- Disconnect compressor from the electrical power supply and protect against unexpected restart.
- Remove the cover of the switch box.
- Switch on the "Test Safety Valve" switch (pressure switch will be deactivated!).
- Mount the cover of the switch box.
- Connect the compressor to the electrical power supply.
- Close filling valves.
- Start the compressor.
- Watch the final pressure gauge. The safety valve should open when reaching working pressure of the compressor. If not, switch off the unit and take out of service until the safety valve has been replaced.
- Switch off the compressor.
- Disconnect the compressor from the electrical power supply and protect against unexpected restart.
- Remove the cover of the switch box.
- Switch off the "Test Safety Valve" switch (pressure switch will be activated!).
- Mount the cover of the switch box.
- Connect the compressor to the electrical power supply.

The safety valve test is now completed.

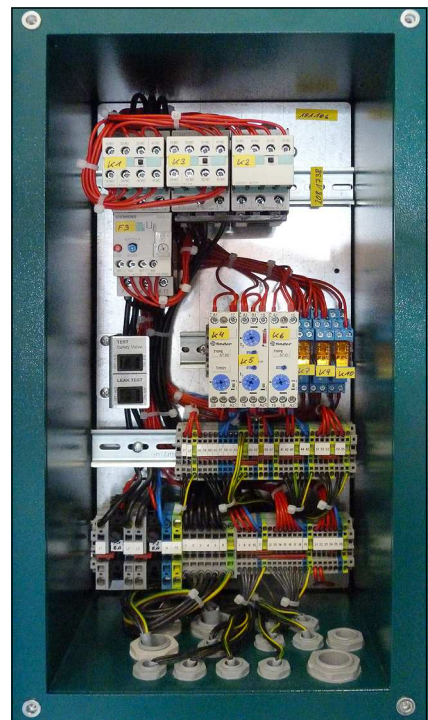

Switch box



Safety valve test switch (up)



AUTO SHUT DOWN

Druckschalter / Pressure Switch

Best.-Nr. / Order No.	Benennung	Description
000203	Druckschalter 50-350 bar	Pressure Switch 50-350 bar
000749	Verschraubung, mit fester Mutter	Connection with fixed nut
000757	T-Verschraubung mit fester Mutter seitl. EL 08 L	T-Connection with fixed nut EL 08 L
000765	Schneidring PSR 08 LX	Olive Seal PSR 08 LX
000766	Mutter 08L CFX	Nut 08L CFX

D

AUTO SHUT DOWN

Druckschalter / Pressure Switch

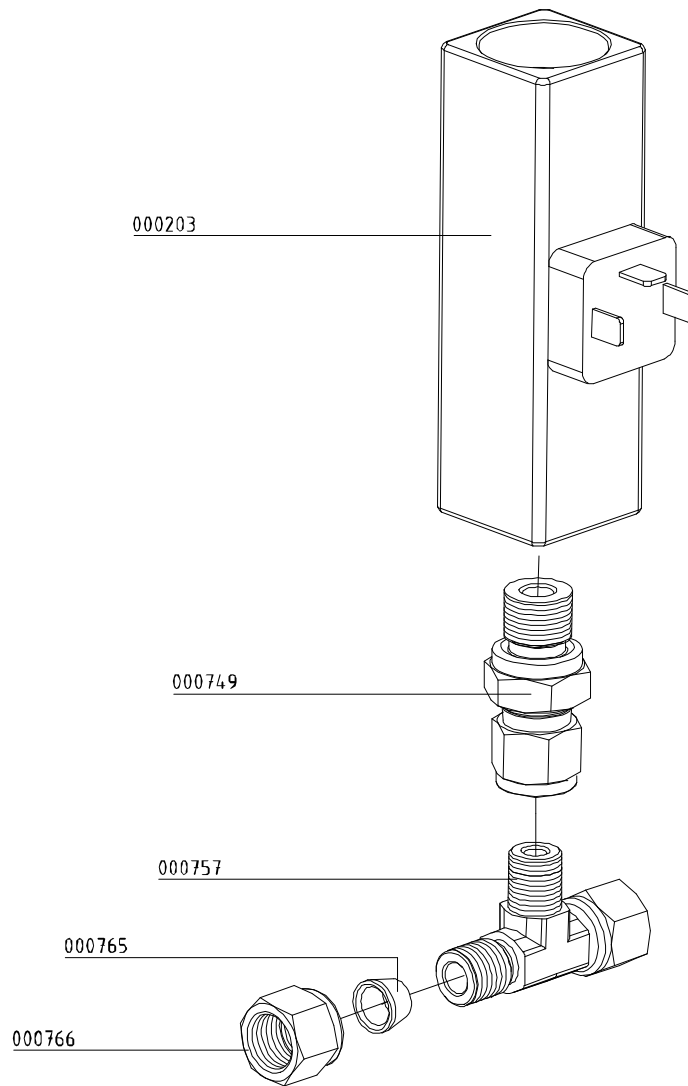

D



AUTOMATIC CONDENSATION DRAIN

D

AUTOMATIC CONDENSATION DRAIN

Automatic condensation dump system



Note

The collected condensate can contain oil and has to be disposed according to regulations.

The LW 570 E Compact is optional with an automatic condensation dump system available. Solenoids drain all condensate separators every 15 minutes.

To test the system, press the blue condensate test drain button on the operating panel.

Oil / water separators

Condensate is separated after every stage of compression. All oil / water separators are equipped with electronic timer controlled solenoids. The timer is located in the switch box and activates the dump valves about every 15 minutes.

To release the complete condensate through the black plastic hoses, we recommend using an 20 l container at least.

The drain noise can be kept to a minimum by using a silencer.

Maintenance intervals

We recommend to clean oil and water separators every 500 operating hours or at least once a year, to check for corrosion damage and to replace o-rings if necessary.

All oil / water separators have an integrated sinter filter which has to be replaced every 1,000 operating hours.

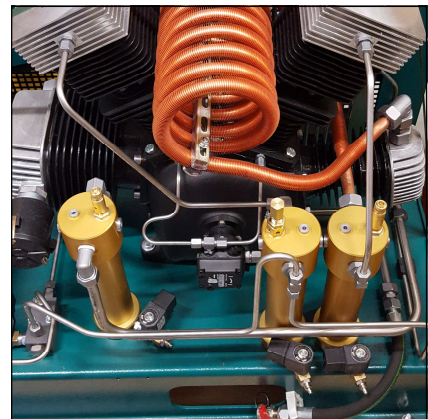

Oil / water separators 1st and 2nd stage

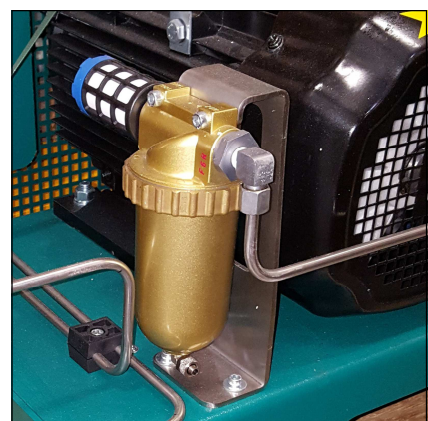

Oil / water separators final stage

AUTOMATIC CONDENSATION DRAIN

Leak test



Note

Do not fill any tank during test phase!

Leak test as follows:

- Disconnect the compressor from the electrical power supply and protect against unexpected restart.
- Remove the cover of the switch box.
- Switch on the leak test switch (solenoid valves will be deactivated!).
- Mount the cover of the switch box.
- Connect the compressor to the electrical power supply.
- Close filling valves.
- Start the compressor.
- Switch off the compressor at a pressure of approx. 150 bar.
- Verify the compressor for release noises. (A slight hiss of the air inlet filter nozzle can be ignored). If release noises occur, localise blow off position(s).
- Switch off the compressor.
- Disconnect the compressor from the electrical power supply and protect against unexpected restart.
- Remove the cover of the switch box.
- Switch off the leak test switch (solenoids will be activated!).
- Mount the cover of the switch box.
- Connect the compressor to the electrical power supply.

The leak test is now completed.

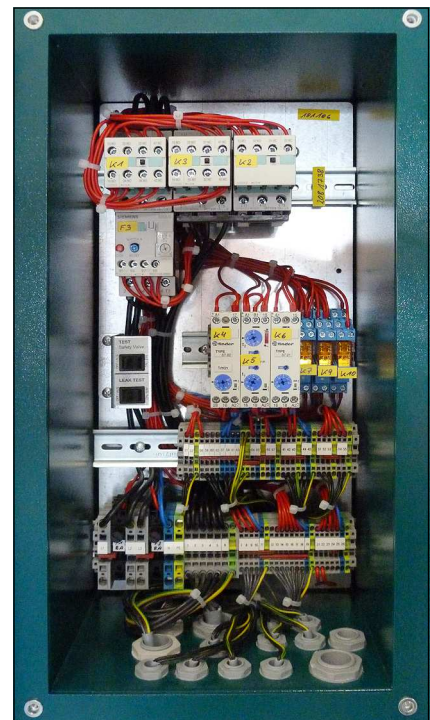

Switch box



Leak test switch (lower)

AUTOMATIC CONDENSATION DRAIN

Oil / water separators final stage - maintenance



Note

Clean all parts thoroughly before assembly.

Change/clean oil / water separators final stage as follows:

- Loosen pipe and mounting screws.
- Remove oil / water separators.
- Open ring nut and remove separator top (Fig. 1).
- Loosen nut at the separator top.
- Change sinter filter (Fig. 2).
- Reassemble all parts and tighten nut.
- Change o-ring, previously grease new o-ring (Fig. 3).
- Place separator top and tighten ring nut manually.
- Replace silencer.
- Mount oil / water separators.
- Tighten pipe and mounting screws.

The oil / water separator maintenance is now completed.

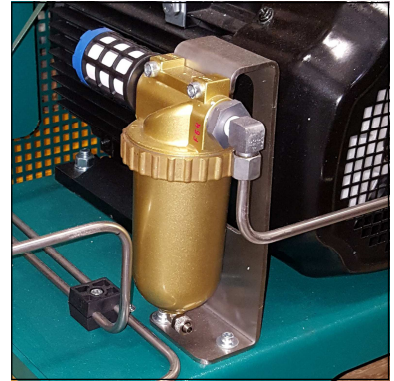

Oil / water separators final stage



Fig. 1 - Loosen ring nut

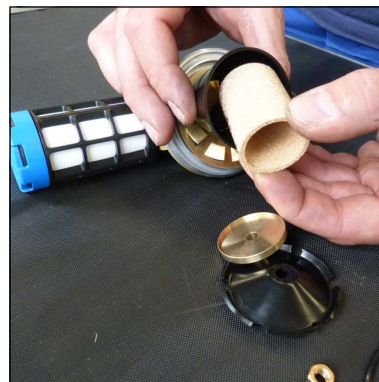

Fig. 2 - Change sinter filter

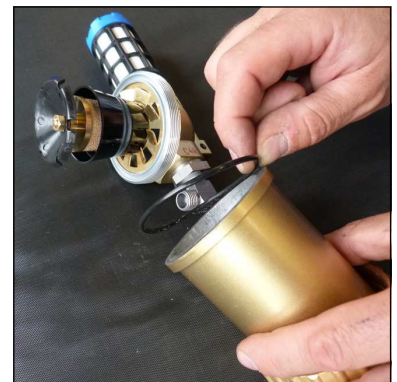

Fig. 3 - Change o-ring

AUTOMATIC CONDENSATION DRAIN

Pneumatic condensate valve - maintenance



Note

Clean all parts thoroughly before assembly.

Pneumatic condensate valve change as follows:

- Loosen pipe connections and mounting screws.
- Remove pneumatic condensate valve.
- Loosen connection (Fig. 2).
- Change sinter filter (Fig. 3).
- Tighten horizontal screw.
- Mount pneumatic condensate valve.
- Tighten pipe connections and mounting screws.

Pneumatic condensate valve maintenance is now completed.

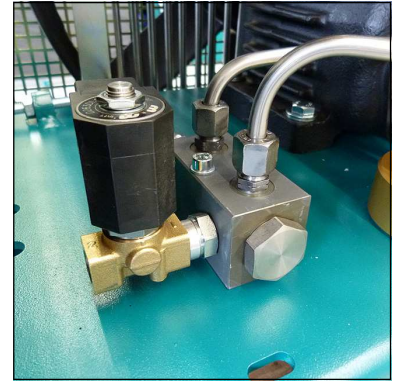

Pneumatic Condensate Valve



Fig. 2 - Loosen connection

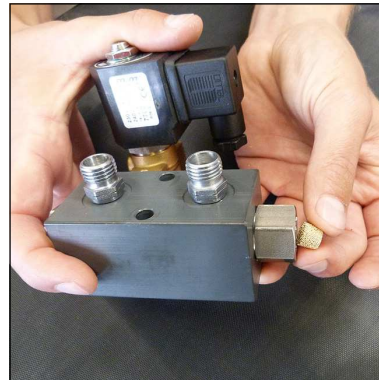

Fig. 3 - Change sinter filter



AUTOMATIC CONDENSATION DRAIN

Öl- / Wasserabscheider Endstufe / Oil- / Water Separator Final Stage

Best.-Nr. / Order No.	Benennung	Description
000175	Abweiser Öl-/ Wasserabscheider	Deflector Oil/Water Separator
000178	Schalldämpfer G1/2"	Silencer G1/2"
000183	Wasserabweiser	Filter Protecor
000184	Sinterfilter Wasserabscheider	Siltered Filter, Oil Filter
000185	Halteteller	Plate, water separator
000186	Drallscheibe, z.B. 1. Stufe	Twist Disk, 1st. Stage
000498	U-Scheibe A6	Washer A6
000761	Winkerverschraubung	Elbow Connection
000921	Reduzierung	Reducer
001027	Zylinderschraube	Allen Bolt
001039	Zylinderschraube	Allen Bolt
001156	Stopfmutter	Lock Nut M6
001181	U-Scheibe A8	Washer A8
001294	O-Ring Wasserabscheider, Endabscheider	O-Ring, water separator
001431	Klemmring Wasserabscheider	Lock Ring Water Separator
002409	nicht mehr lieferbar, 005856 verwenden	Quick release coupling elbow
002466	Kondensatbehälter für Abscheider	Condensate Bowl, alloy (gold)
002563	Wasserabscheider Oberteil	Water Separator, Top
007972	Halterung Endabscheider	Bracket final separator

D

AUTOMATIC CONDENSATION DRAIN

Öl- / Wasserabscheider Endstufe / Oil- / Water Separator Final Stage

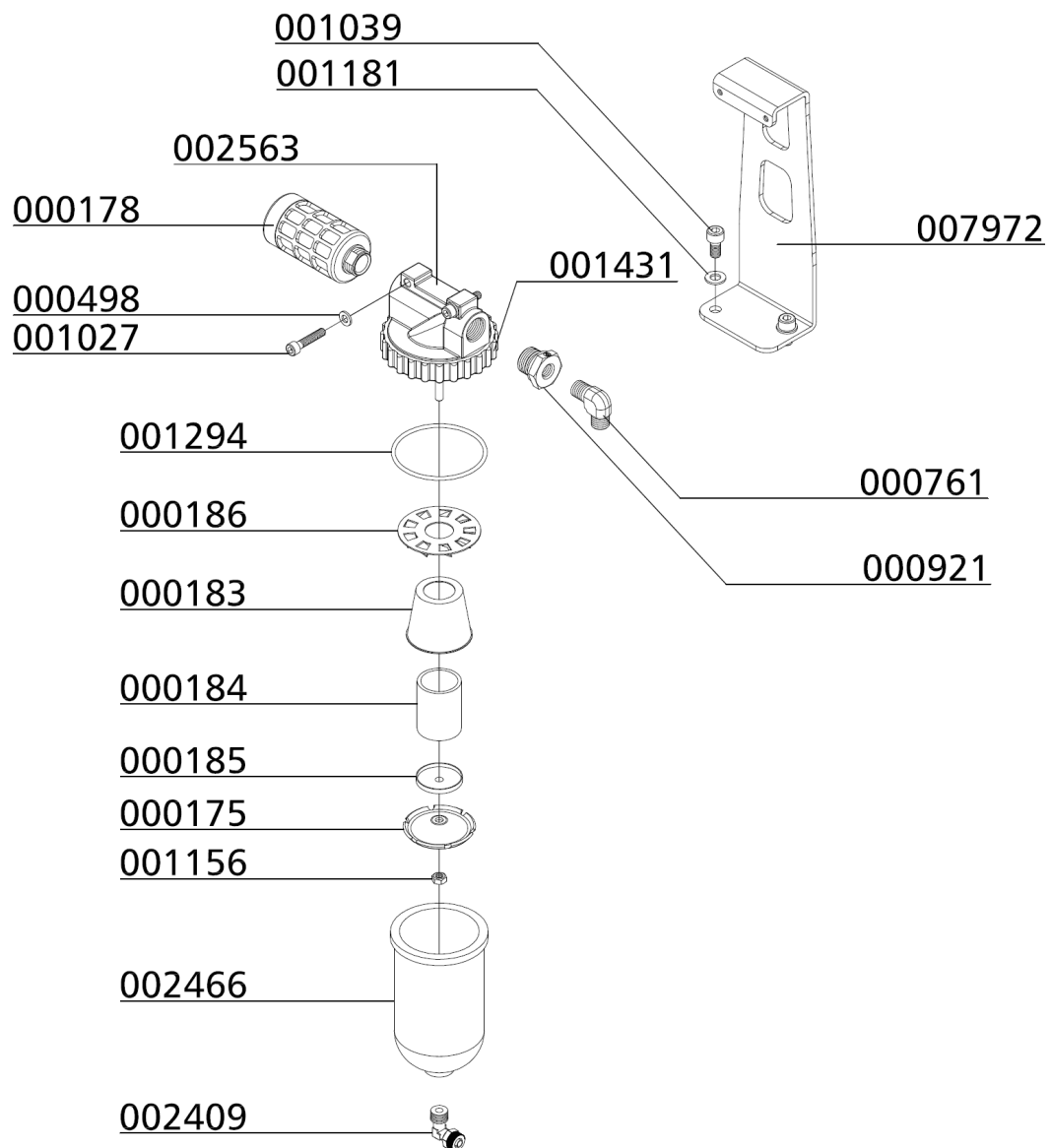

D



AUTOMATIC CONDENSATION DRAIN

Pneum. Kondensat-Ablassventil / Pneumatic Condensate Valve

Best.-Nr. / Order No.	Benennung	Description
000188	Sinterfilter	Sintered Filter
000191	Steuerkolben, pneum. Kondensatventil	Piston
000194	Reparatursatz pneum. Kondensatventil	Repair Kit Condensate Valve
000196	Düzenschraube, pneum. Kondensatventil	Inlet Jet Screw
000197	Stopfen, pneum. Kondensatventil	Plug
000198	Gehäuse, pneum. Kondensatventil	Body PCV
000199	Pneum. Kondensatventil (Kondensatablassventil)	Pneumatic Condensate Valve
000498	U-Scheibe DIN 125 A6	Washer DIN 125 A6
000737	Verschraubung GE08LR1/8CFX	Connection GE08LR1/8CFX
000738	Verschraubung GE08LR1/8CFX	Connection GE08LR1/8CFX
000765	Schneidring PSR 08 LX	Olive Seal PSR 08 LX
000766	Mutter M08LCFX	Union Nut M08LCFX
001011	Zylinderschraube M6x60mm DIN912 8.8 ZN	Allen Bolt M6x60mm DIN912 8.8 ZN

D

AUTOMATIC CONDENSATION DRAIN

Pneum. Kondensat-Ablassventil / Pneumatic Condensate Valve

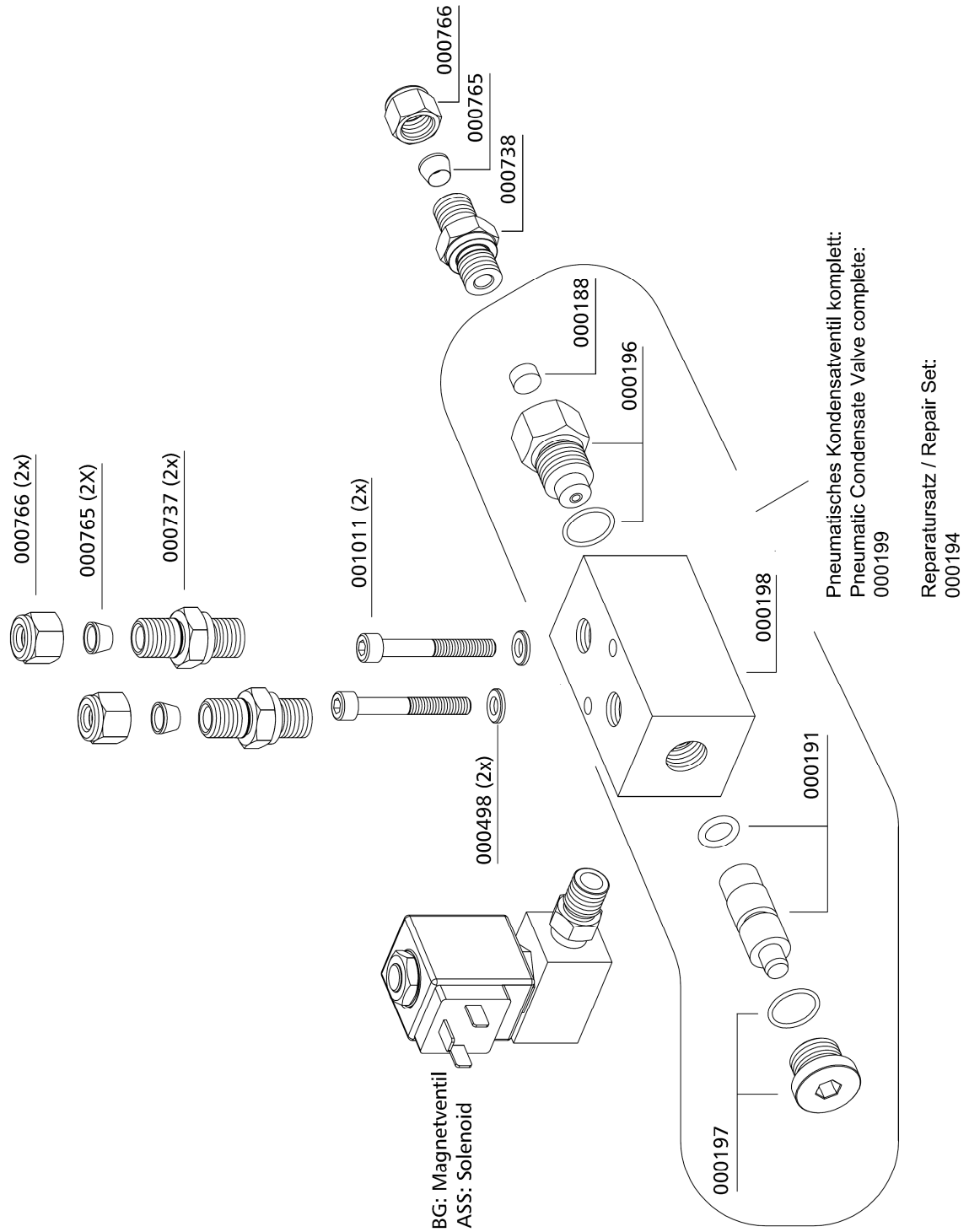

D

AUTOMATIC CONDENSATION DRAIN

Baugruppe: Magnetventil / Assembly: Solenoid

Best.-Nr. / Order No.	Benennung	Description
000892	Doppelnippel 4F3MK4S G1/8"-1/4"	Double Nipple 4F3MK4S G1/8"-1/4"
001546	Aludichtring für Magnetventile G1/4", 18 x 13,2 x 2,5mm	Alloy Seal Ring for solenoid G1/4", 18 x 13,2 x 2,5mm
005857	Gerade Einschraubverschraubung, G1/4" - 8 mm	Straight Hose Connection, G1/4" - 8 mm
006113	Magnetventil 0-55bar, komplett mit Spule	Solenoid 0-55bar, c/w coil

D

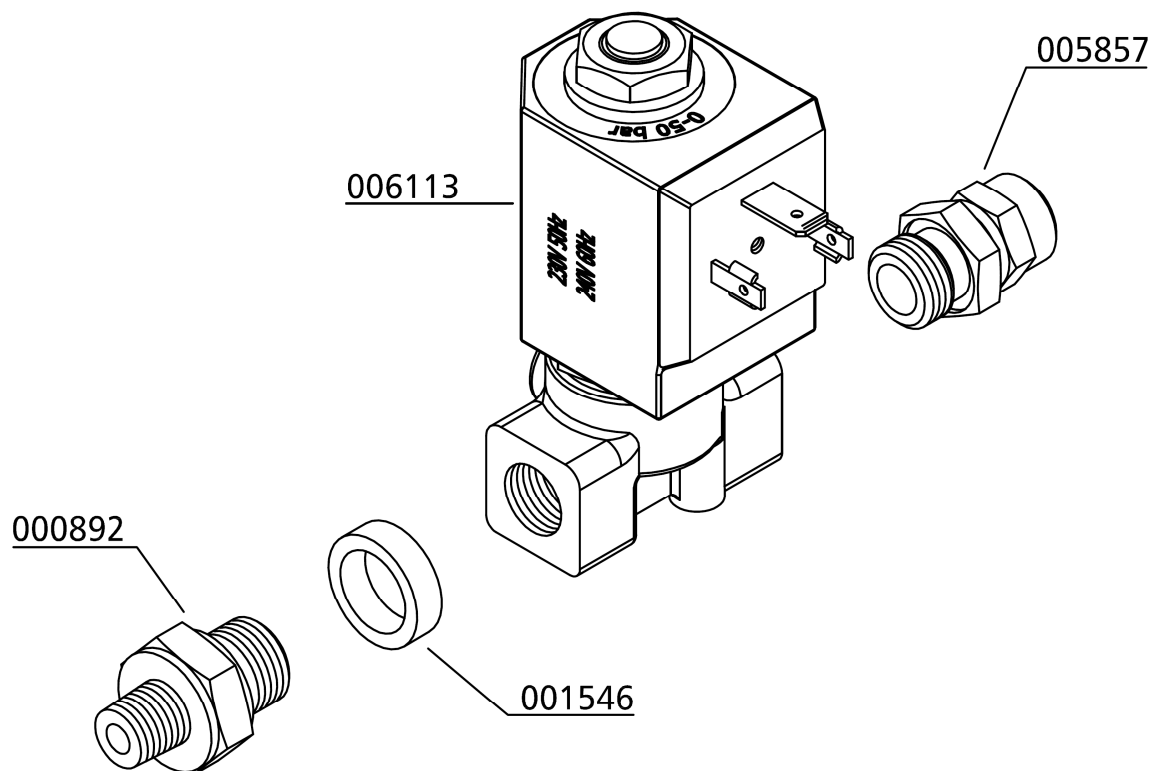

AUTOMATIC CONDENSATION DRAIN

Switch box with condensate drain test switch

Best.-Nr. / Order No.	Benennung	Description
002089	Betriebsstundenzähler	Hour counter
002502	Kondensat Test Schalter	Drain test switch
002942	START/STOP Schalter mit LED	Start/Stop switch c/w LED
003121	NOT-AUS Schalter	Emergency switch
004704	Warnlampe	Warning Lamp
005670	Einlegeschild Kondensat Test	Label Drain Test
006859	Schildträger	Label holder
006925	Einlegeschild Motorschutz	Label Motor protect

D





AUTO START FUNCTION

D

AUTO START FUNCTION

Auto Start Function

The auto start function allows operating the compressor optionally in automatic or semi-automatic mode by turning the selector switch.

Semi-automatic operation:

Start the compressor by pushing the Start button. The compressor automatically shuts off when final pressure is reached. To restart the compressor, push the Start button again. The unit can be shut down at any time during operation by pushing the Stop button.



Selector switch auto start function

Automatic operation:

Start the compressor only once by pushing the Start button. The Start button lights up and the unit automatically shuts off when final pressure is reached. If outlet pressure decreases below the selected minimum pressure, the unit automatically restarts.



Note

The compressor can not be manually started during automatic operation.

To enable a manual start, shut off automatic operation by pushing the Stop button (Start button lamp goes out). Now turn selector switch to semi-automatic mode and start the compressor with the Start button.

Adjust re-start pressure (minimum filling pressure)

The pressure switch for start pressure is located after the pressure maintaining valve. The pressure can be adjusted with the upper adjusting screw.

Increasing re-start pressure: turn adjusting screw clockwise

Reducing re-start pressure: turn adjusting screw anti-clockwise

Adjust pressure switch in steps of a quarter turn. Check settings after every adjustment step.

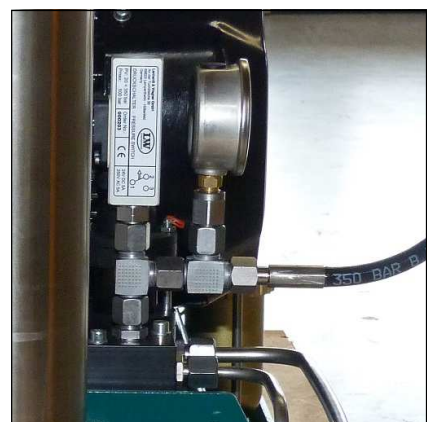

Adjust re-start pressure

AUTO START FUNCTION

Filling procedure semi-automatic operation



Caution! Only fill cylinders which:

- are marked with the test mark and the test stamp of the expert.
- have been hydro static tested (check last test date).
- are rated for the final pressure.
- are free from humidity.



Note

The unit shuts down when final pressure is reached. Thus, the unit always has to be restarted manually.

1. Turn selector switch to semi-automatic mode.
2. Close all filling valves.
3. Connect closed compressed air cylinders.
4. Open filling valves.
5. Start compressor by pushing the ON button.
6. When filling pressure gauge increases, open filling valves slowly.
7. Fill compressed air cylinders to the desired pressure, subsequently close filling valves slowly.
8. Close and vent all filling valves.
9. Disconnect all compressed air cylinders from filling valves.

AUTO START FUNCTION

Filling procedure automatic operation



Caution! Only fill cylinders which:

- are marked with the test mark and the test stamp of the expert.
- have been hydro static tested (check last test date).
- are rated for the final pressure.
- are free from humidity.



Note

The unit shuts down when final pressure is reached. Thus, the unit always has to be restarted manually.

1. Turn selector switch to automatic mode.
2. Close all filling valves.
3. Connect closed compressed air cylinders.
4. Open filling valves.
5. Start compressor by pushing the ON button.
6. When filling pressure gauge increases, open filling valves slowly.
7. Fill compressed air cylinders to the desired pressure, subsequently close filling valves slowly.
8. Close and vent all filling valves.
9. Disconnect all compressed air cylinders from filling valves.
10. If automatic operation is interrupted by:
 - pushing the OFF button
 - turning the selector switch
 - tripping the emergency shut-off switch
 - opening of the doors or the coverthe unit has to be restarted.



AUTO START FUNCTION

Spare part lists

Best.-Nr. / Order No.	Benennung	Description
000203	Druckschalter 50-350 bar	Pressure Switch 50-350 bar
000652	Manometer 0-400 bar	Pressure Gauge 0-400 bar
000794	T-Verschraubung mit fester Mutter	T-Connection with fixed nut
001440	Hochdruckschlauch 10L (1500mm)	High Pressure Hose 10L (1500mm)
005812	Manometerverschraubung	Pressure Gauge Connection

D

AUTO START FUNCTION

Spare part lists

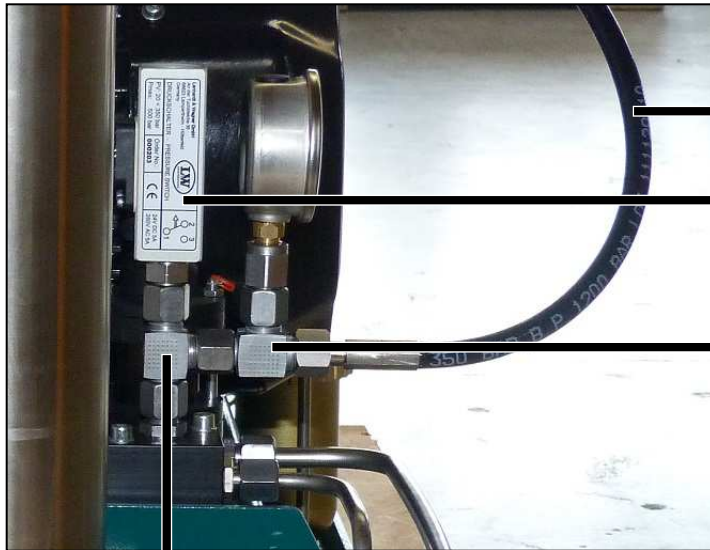

001440

000203

000794

000794

D



000652

005812



OIL PRESSURE GAUGE

D

OIL PRESSURE GAUGE

Oil pressure gauge

The oil pressure gauge shows the compressor oil pressure during operation. Oil pressure values at operating temperature should remain between:

- min. + 1.3 bar
- max. + 1.5 bar

If oil pressure value stays below the minimum value:

- Wrong compressor rotation direction (see rotation direction arrow)
- Oil level too low, not enough oil in the compressor
- Oil pump sieve contaminated
- Oil intake hose damaged / defective
- Oil temperature below +5 °C - lubrication not possible
- Oil temperature higher than +120 °C - oil viscosity too low
- Oil pump defective

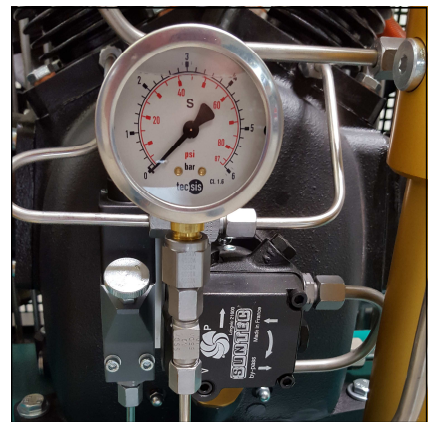

Oil pressure gauge

D

If oil pressure value stays above the maximum value:

- Low oil temperature, between +5 °C and +10 °C
- Should stay within the range of tolerance when operation temperature is reached..

Oil pressure control

If oil pressure remains outside the range of tolerance, it can be adjusted at the oil pump.

Increasing oil pressure

- Turn adjusting screw clockwise

Reduce oil pressure

- Turn adjusting screw anti-clockwise



Adjusting the oil pressure



Warning

Only adjust the oil pressure at operating temperature!

OIL PRESSURE GAUGE

Spare part lists

Best.-Nr. / Order No.	Benennung	Description
000721	Verschraubung	Connection
000769	Verschraubung	Connection Pressure Gauge
000777	Dichtring für Manometerverschraubung	Seal Ring for Pressure Gauge
005226	Manometer	Press. Gauge

D

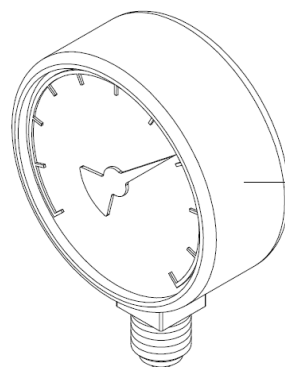

005226

000777

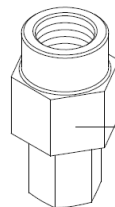

000769

000721

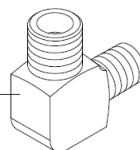



OIL PRESSURE MONITORING

D

OIL PRESSURE MONITORING

Oil pressure monitoring

The oil pressure is maintained by a pressure switch during operation. The compressor automatically shuts off when oil pressure decreases below the minimum pressure of +0.5 bar. The red warning lamp "Oil Pressure Monitoring" lights up.

Possible causes of fault:

- Wrong compressor rotation direction
(see rotation direction arrow)
- Oil level too low, not enough oil in the compressor
- Oil pump sieve contaminated
- Oil intake hose damaged / defective
- Oil temperature below +5 °C - lubrication not possible
- Oil temperature higher than +120 °C - oil viscosity too low
- Oil pump defective



Oil Pressure Monitoring



OIL PRESSURE MONITORING

Spare part lists

Best.-Nr. / Order No.	Benennung	Description
004701	Warnlampe	Warning Lamp
004703	Schild	Label
004704	Relais für Warnlampe	Relais for warning lamp
005261	Öldruckschalter	Oil Pressure Switch
005482	Halteblech Öldruckschalter	Bracket Oil Pressure Switch
005483	Rohrleitung	Pipe
006859	Schildträger	Label holder

D

OIL PRESSURE MONITORING

Spare part lists

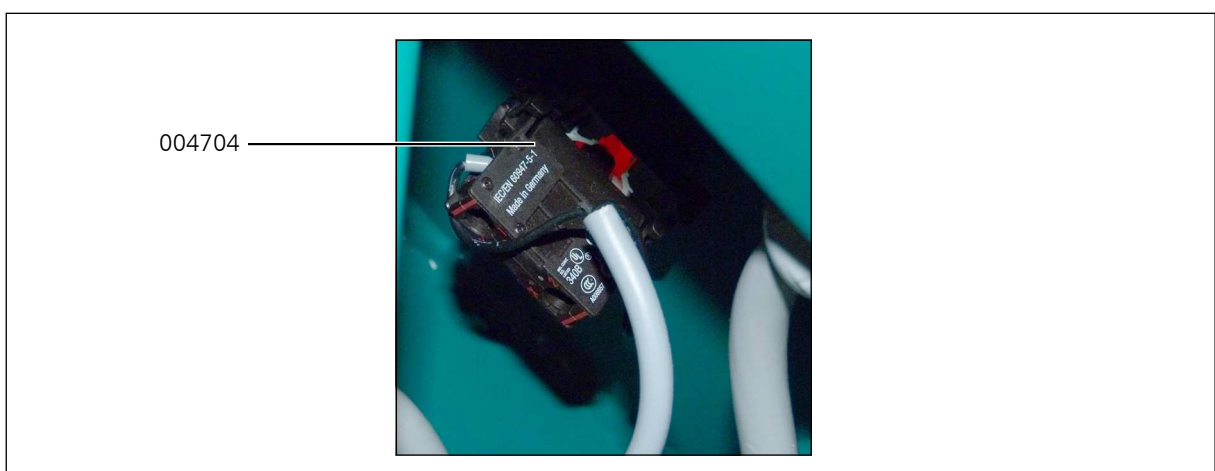
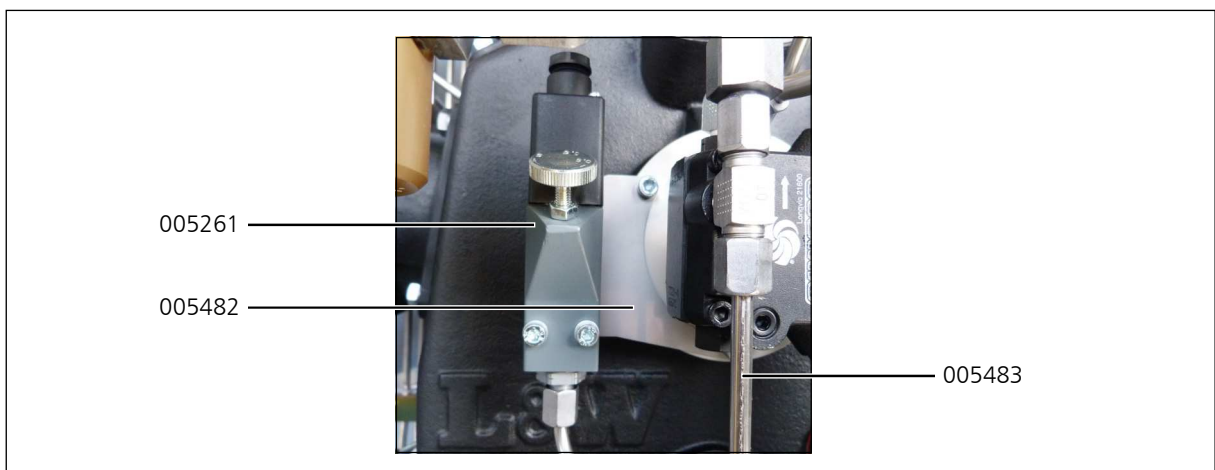



OIL PRESSURE MONITORING

Baugruppe: Öldrucküberwachung / Assembly: Oil Pressure Monitoring

Best.-Nr. / Order No.	Benennung	Description
000712	Verschraubung	Connection w/o nut& olive seal
000716	Verschraubung	Connection w/o nut& olive seal
000769	Verschraubung	Connection Pressure Gauge
000777	Dichtring für Manometerverschraubung	Seal Ring for Pressure Gauge
001021	Zylinderschraube	Allen Bolt
001151	Mutter	Nut M5
001176	U-Scheibe A5	Washer A5
005226	Manometer 0-6 bar Ø63mm	Pressure Gauge 0-6 bar Ø63mm
005261	Druckschalter inkl. Stecker	Oil Pressure Switch 0.2-2 bar
005482	Halteblech Öldruckschalter	Bracket Oil Pressure Switch
005483	Öldruckleitung zu Öldruckschalter	Oil Pressure Pipe 6 mm, s/s

D

OIL PRESSURE MONITORING

Baugruppe: Öldrucküberwachung / Assembly: Oil Pressure Monitoring

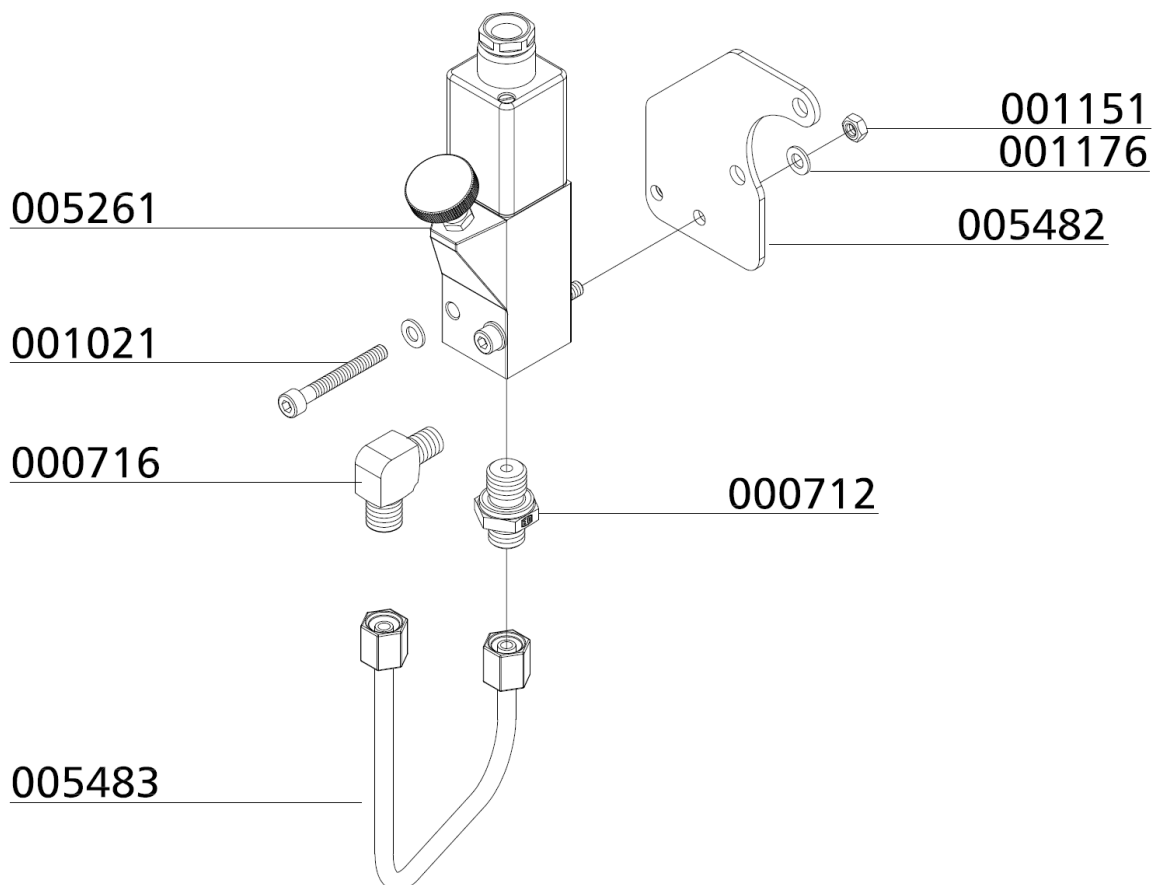

D

OIL PRESSURE MONITORING

Baugruppe: Öldrucküberwachung / Assembly: Oil Pressure Monitoring

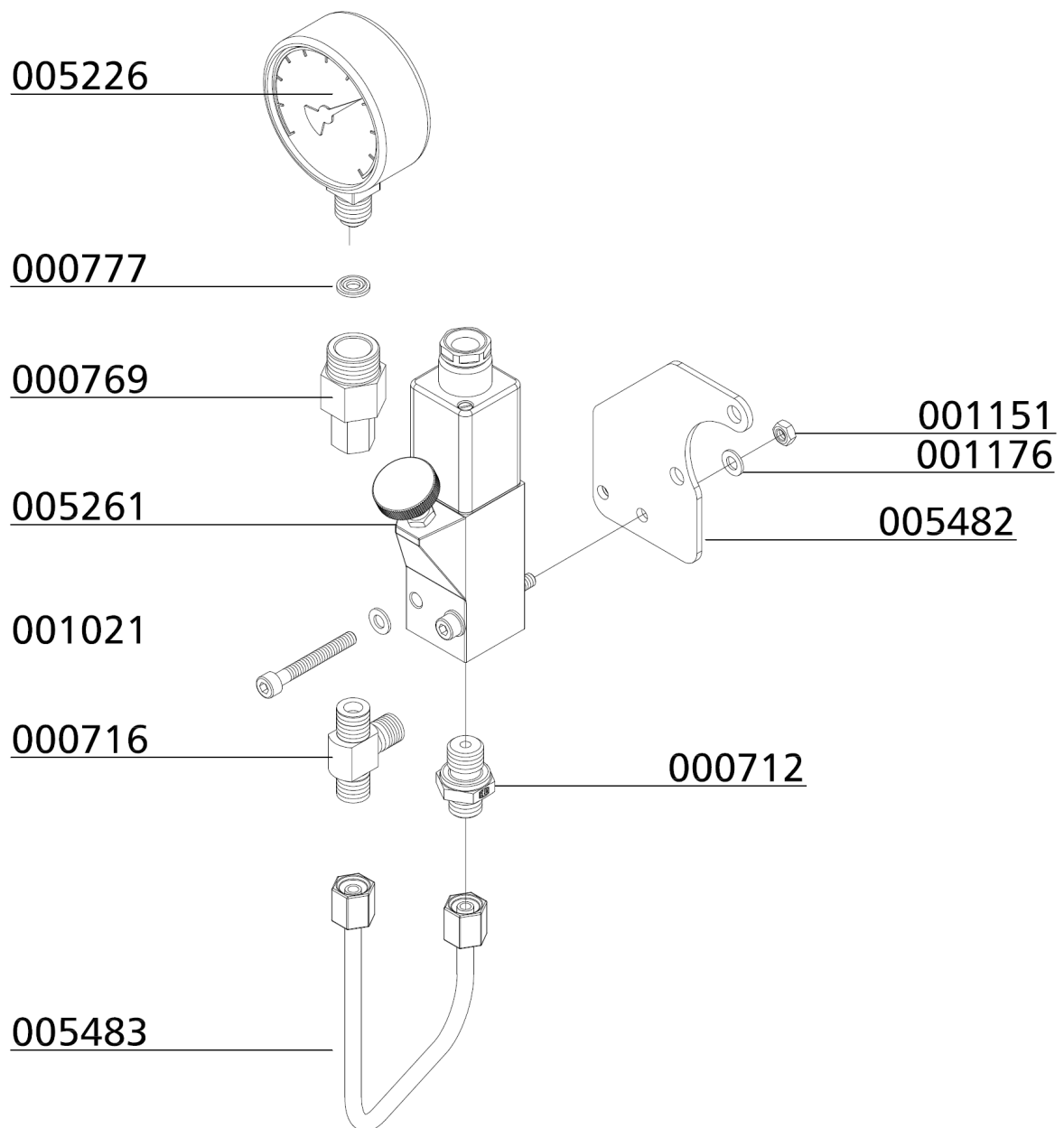

D



OIL TEMPERATURE MONITORING

D

OIL TEMPERATURE MONITORING

Oil temperature monitoring

Oil temperature monitoring

The oil temperature is maintained by a temperature sensor inside the compressor block during operation.

The compressor automatically shuts off when oil temperature exceeds the maximum pressure of +100 °C. The red warning lamp "Oil Temperature Monitoring" lights up.

Possible causes of fault:

- Ambient temperature too high
- Cooling air flow not sufficient
- Oil level too low
- Cooling pipes contaminated



Oil Pressure Monitoring



Warning

Risk of burns!

Allow the unit to cool before beginning troubleshooting.

OIL TEMPERATURE MONITORING

Spare part lists

Best.-Nr. / Order No.	Benennung	Description
004342	Display	Display
004730	Display und Sensor	Display and Sensor

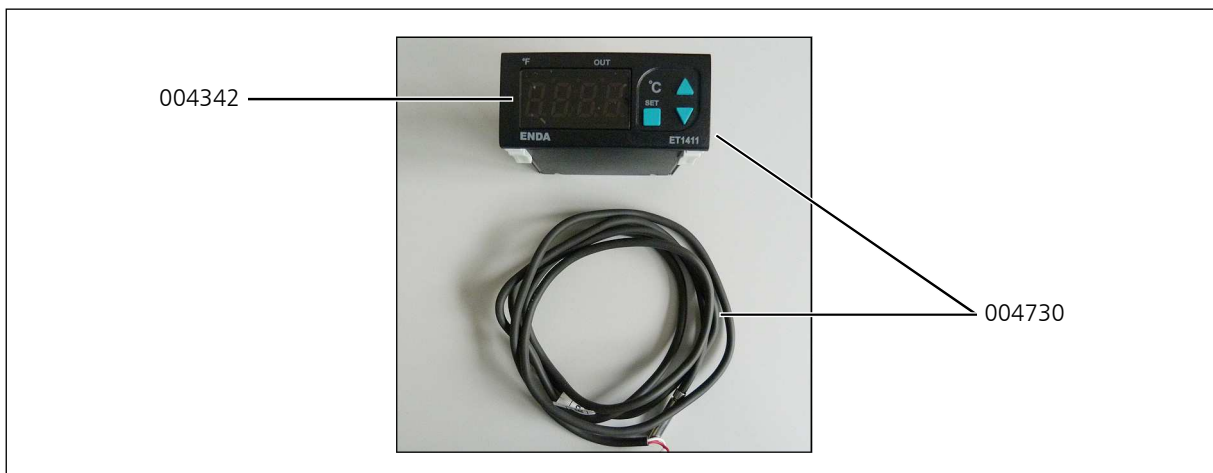

D



CYLINDER HEAD TEMPERATURE MONITORING

D

CYLINDER HEAD TEMPERATURE MONITORING

Cylinder head temperature monitoring

The cylinder head temperature is maintained by a temperature sensor at the cylinder head of the high pressure stage during operation. The compressor shuts off automatically when cylinder head temperature exceeds the maximum pressure of +120° C. The red warning lamp "Cylinder Head Temperature Monitoring" lights up.

Possible causes of fault:

- Ventilation of the compressor room is not sufficient
- Cooling air flow not sufficient
- Cooling pipes contaminated



Warning

Risk of burns!

Allow the unit to cool before beginning troubleshooting.

CYLINDER HEAD TEMPERATURE MONITORING

Spare part lists

Best.-Nr. / Order No.	Benennung	Description
004726	Display	Display
005585	Sensor	Sensor
007613	Ventilkopf (Spezielle Version)	Valve Head (special version)

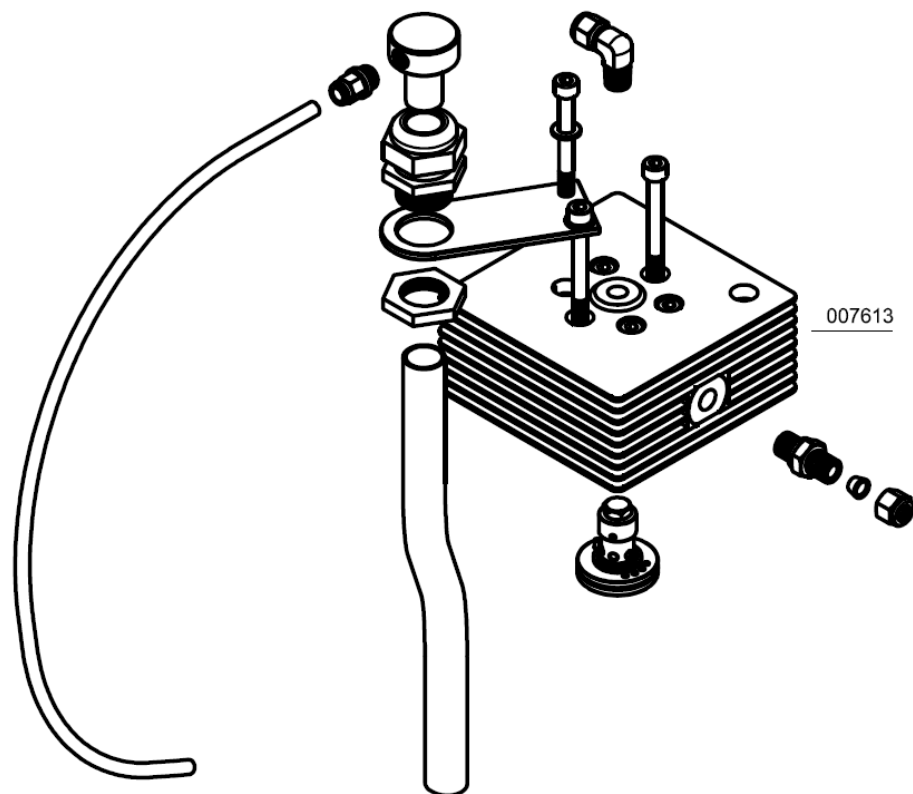
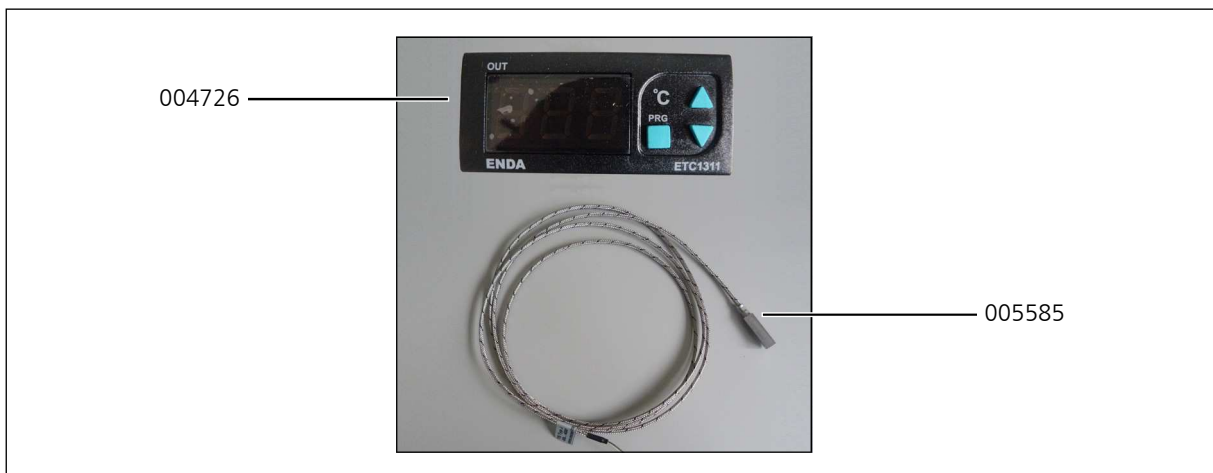

D



INTERSTAGE PRESSURE GAUGES

D

INTERSTAGE PRESSURE GAUGES

Interstage pressure gauges

Each of the 3 pressure stages is monitored by a single pressure gauge. This is serviceable for troubleshooting and allows detecting faults at an early stage.

Indicated interstage pressures depend on final pressure settings.

The pressure gauges should show the following values at a final pressure of 300 bar:

1. 1st stage: approx. 3,5 bar
2. 2nd stage: approx. 15 bar
3. 3rd stage: approx. 67 bar
4. 4th stage: approx. 300 bar

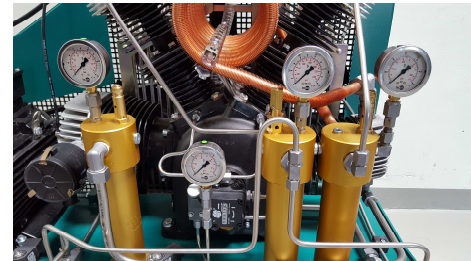

Interstage pressure gauges

INTERSTAGE PRESSURE GAUGES

Spare part lists

Best.-Nr. / Order No.	Benennung	Description
000660	Einbaumanometer mit Befestigungsbügel	Press. Gauge c/w fixing strap
000710	Verschraubung	Connection w/o nut& olive seal
000761	Winkelverschraubung	Elbow Connection
000769	Verschraubung	Connection Pressure Gauge
000857	Reduzierung	Reducer with fixed nut
002507	Einbaumanometer glyzeringefüllt	Pressure Gauge 0-10bar
005539	Einbaumanometer glyzeringefüllt Messing	Press. Gauge c/w fixing strap

C

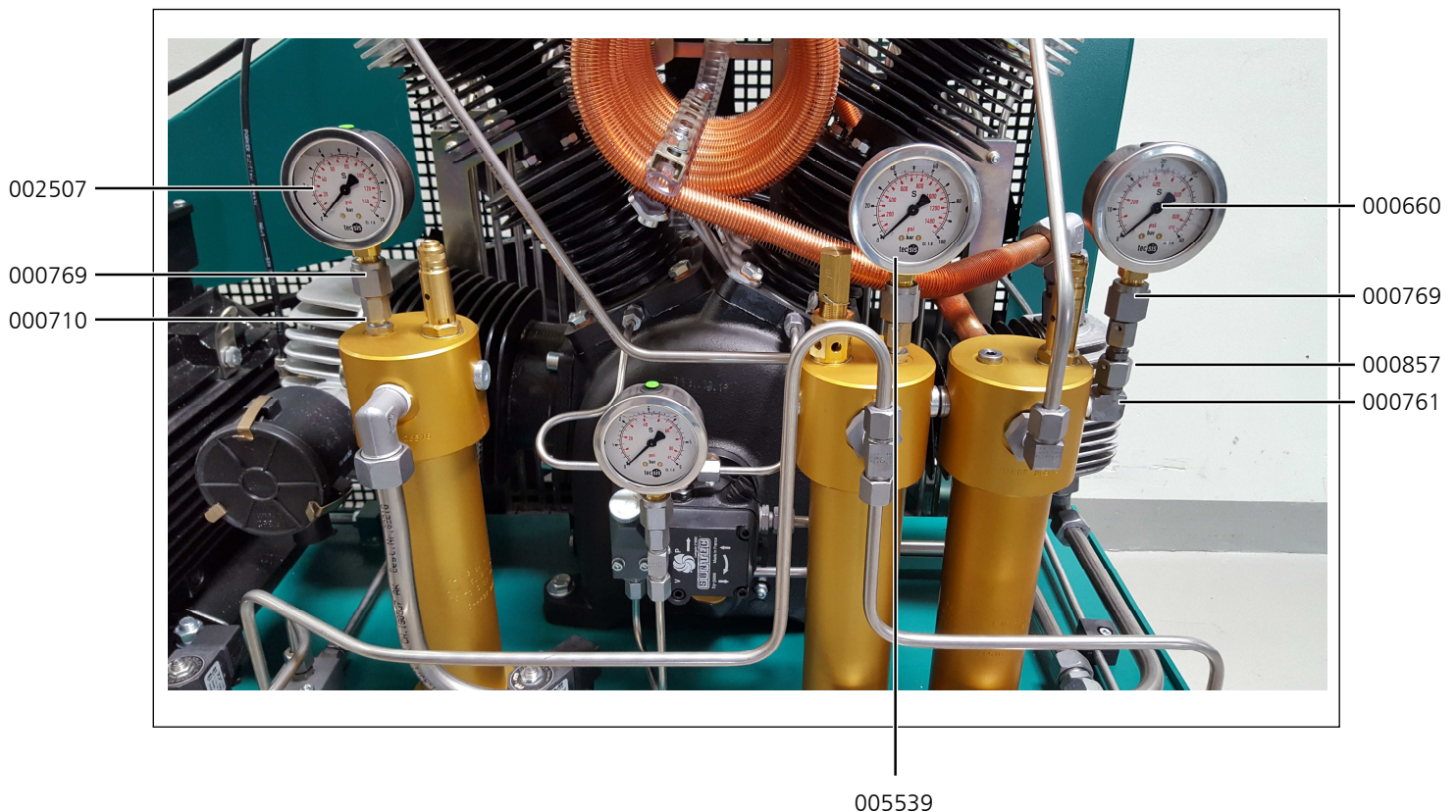



0.8 LTR PREFILTER

D

MAINTENANCE AND SERVICE

Service, Repair and Maintenance

Carry out service and maintenance work exclusively when the compressor is stopped and depressurised. The unit should be leak-checked regularly. Leaks can be preferably localised by using a leak detector spray (if necessary, brush pipes with soapy water).

We recommend that only authorised L&W service technicians carry out service work on the bearing of the compressor (crankshaft and connecting rods).

We urgently recommend that all maintenance, repair and installation work must only be carried out by trained personnel. This is necessary because all maintenance work can not be explained exactly and detailed in this manual.

Only use authentic spare parts for service work.



Danger

Components under pressure, such as hose ends, can quickly come loose when manipulated and can cause potentially fatal injuries due to the pressure surge. Any work on system parts may only be performed in a pressure-compensated state.



Warning

The use of accessories that have not been tested can lead to death or serious injury or damage to the unit. Only use authentic spare parts for service work.



Warning

Carry out maintenance or service work when the unit is switched off and protected against unexpected restart.



Warning

Risk of burns!

Carry out maintenance or service work when the unit has cooled down.



MAINTENANCE AND SERVICE

Every 1000 operating hours

Maintenance work	Type	Quantity	Order No.
Replace o-ring of the 0.8 ltr final filter tower	-	1	004222
Replace back-up ring of the 0.8 ltr final filter tower	-	1	004221
Replace filter element of the 0-8 ltr final filter tower	-	1	003980

D



MAINTENANCE AND SERVICE

Baugruppe: Vorfilter 0,8l / Assembly: Prefilter 0.8ltr

Best.-Nr. / Order No.	Benennung	Description
000761	Winkelverschraubung	Elbow Connection
000838	Verschlussstopfen	Plug
000921	Reduzierung	Reducer
001158	Mutter	Nut M8
001181	U-Scheibe A8	Washer A8
001281	O-Ring	O-Ring
003980	Filterelement	Filter water separator 0.8 Ltr
003994	Filterbehälter 350 bar, V: 0,8 ltr	Filter Unit 0.8 ltr / 350 bar
003997	Filterstütze Partikelfilter 0,8 ltr	Filter support 0,8 ltr
006363	Haltebügel Filtergehäuse 0,8 Liter	U-Clamp Filterhousing 0.8 Ltr
006364	Halteschalen Filtergehäuse 0,8 Liter	Bracket Filter Housing 0.8 ltr

D

Baugruppe: Vorfilter 0,8l / Assembly: Prefilter 0.8ltr

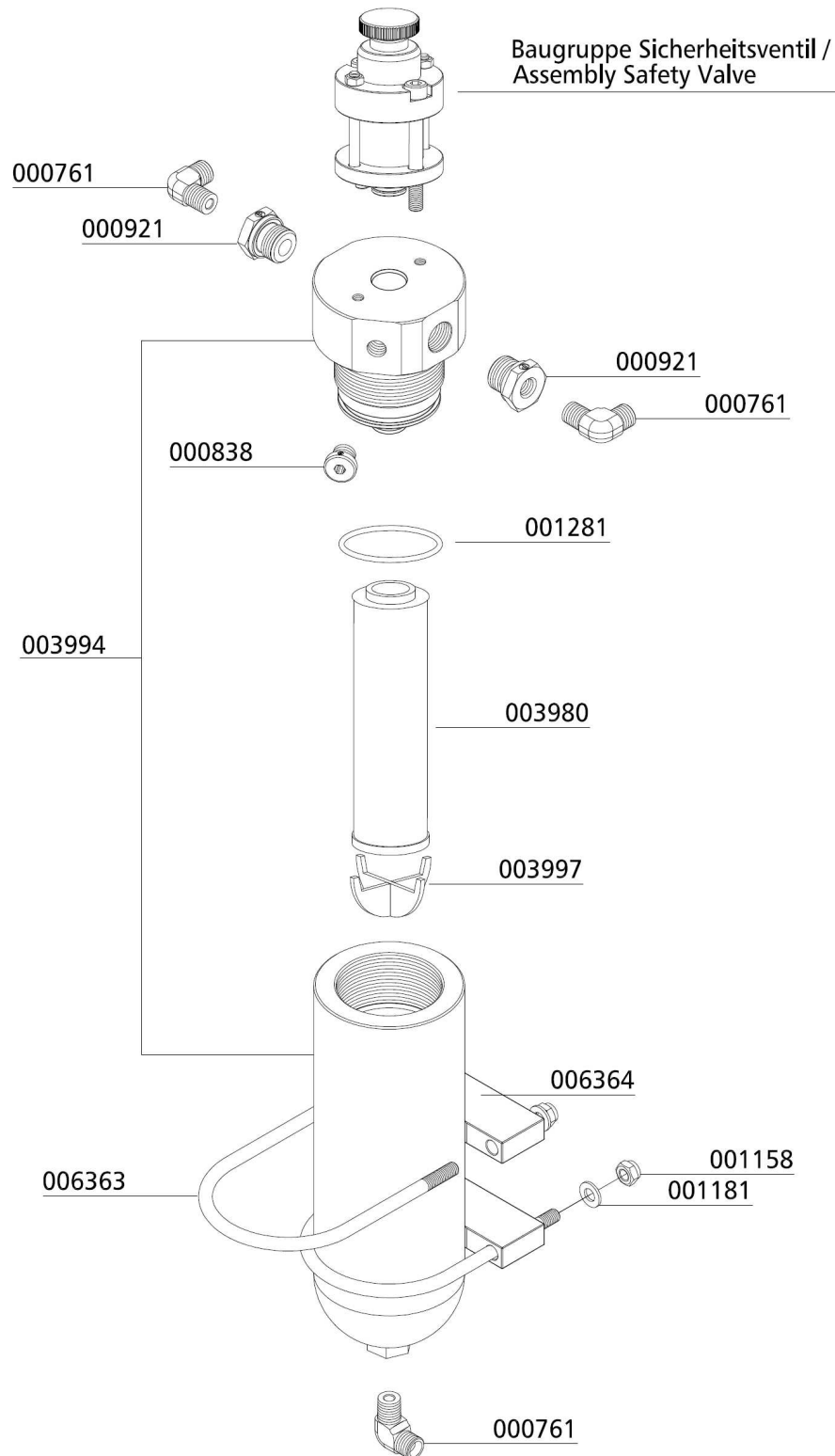

D

MAINTENANCE AND SERVICE

Filter element change 0.8ltr filter housing

Filter element change as follows:

- Start the compressor and run up to a pressure of 100 bar.
- Stop the compressor.
- Open the filling valve.
- Remove HP-pipes and mounting screws (Fig. 1 a. 2)
- Remove complete filter housing.
- Open filter cover (Fig. 3).
- Change the filter element (stuck in filter cover) (Fig. 4).
- Change o-ring, previously grease new o-ring .
- Grease thread of filter cover, o-ring and bach-up ring.
- Reassemble filter cover and filter housing. Note the correct position of th filter back-up!
- After you have screwed it completely, loosen the filter cover about 90 °. This avoids a terminals of the filter cover due to a hard shaking while operation.

The filter cartridge change is now completed.



Note

Ensure that the old filter element is disposed correctly at an approved waste point.



Fig. 1 - Remove HP-pipes and mounting screws



Fig. 2 - Remove HP-pipes and mounting screws

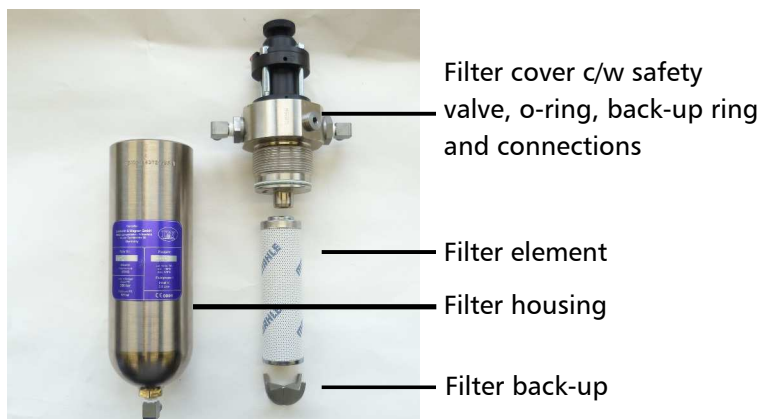

Fig. 4 - 0.8ltr Filter housing parts



Fig. 3 - Open filter cover



**FINAL FILTER SEPARATOR
2.3 LTR**

D

MAINTENANCE AND SERVICE

Service, Repair and Maintenance

Carry out service and maintenance work exclusively when the compressor is stopped and depressurised. The unit should be leak-checked regularly. Leaks can be preferably localised by using a leak detector spray (if necessary, brush pipes with soapy water).

We recommend that only authorised L&W service technicians carry out service work on the bearing of the compressor (crankshaft and connecting rods).

We urgently recommend that all maintenance, repair and installation work must only be carried out by trained personnel. This is necessary because all maintenance work can not be explained exactly and detailed in this manual.

Only use authentic spare parts for service work.



Danger

Components under pressure, such as hose ends, can quickly come loose when manipulated and can cause potentially fatal injuries due to the pressure surge. Any work on system parts may only be performed in a pressure-compensated state.



Warning

The use of accessories that have not been tested can lead to death or serious injury or damage to the unit. Only use authentic spare parts for service work.



Warning

Carry out maintenance or service work when the unit is switched off and protected against unexpected restart.



Warning

Risk of burns!

Carry out maintenance or service work when the unit has cooled down.



MAINTENANCE AND SERVICE

Every 1000 operating hours

Maintenance work	Type	Quantity	Order No.
Replace o-ring of the 2.3 ltr final filter tower	-	1	001287
Replace back-up ring of the 2.3 ltr final filter tower	-	1	001285
Replace filter element of the 0-8 ltr final filter tower	-	1	000003

D



MAINTENANCE AND SERVICE

Baugruppe: Filtergehäuse 2,3l / Assembly: Filter Housing 2.3ltr

Best.-Nr. / Order No.	Benennung	Description
000003	Filterpatrone 2,3 Liter	Filter Cartridge 2.3 ltr BA
000272	Abstandshalter für Filtergehäuse	Spacer Bracket for Filtertower
000383	Messing Adapter für Filterpatrone	Brass Filter Adapter
000384	Düse für Filtergehäuse	Jet Filter Housing
000738	Verschraubung	Connection
000761	Winkelverschraubung	Elbow Connection
001159	Stopfmutter	Lock Nut M8
001181	U-Scheibe A8	Washer A8
001285	Stützring, Filtergehäuse	Back-up Ring Filter Housing
001287	O-Ring, Filtergehäuse	O-Ring filter housing
001461	Filterpatrone	Filter Cartridge
002140	Filterschlüssel 1,7 & 2,3 Liter Behälter	Filter tool 1,7 & 2,3 Litre
002147	Haltebügel für Filtergehäuse (ES)	U-Clamp for filter housing ES
002426	Filtergehäuse	Filter housing
003077	Entwässerungsventil G1/4" AG, konisch	Drain Valve G1/4" male

D

MAINTENANCE AND SERVICE

Baugruppe: Filtergehäuse 2,3l / Assembly: Filter Housing 2.3ltr

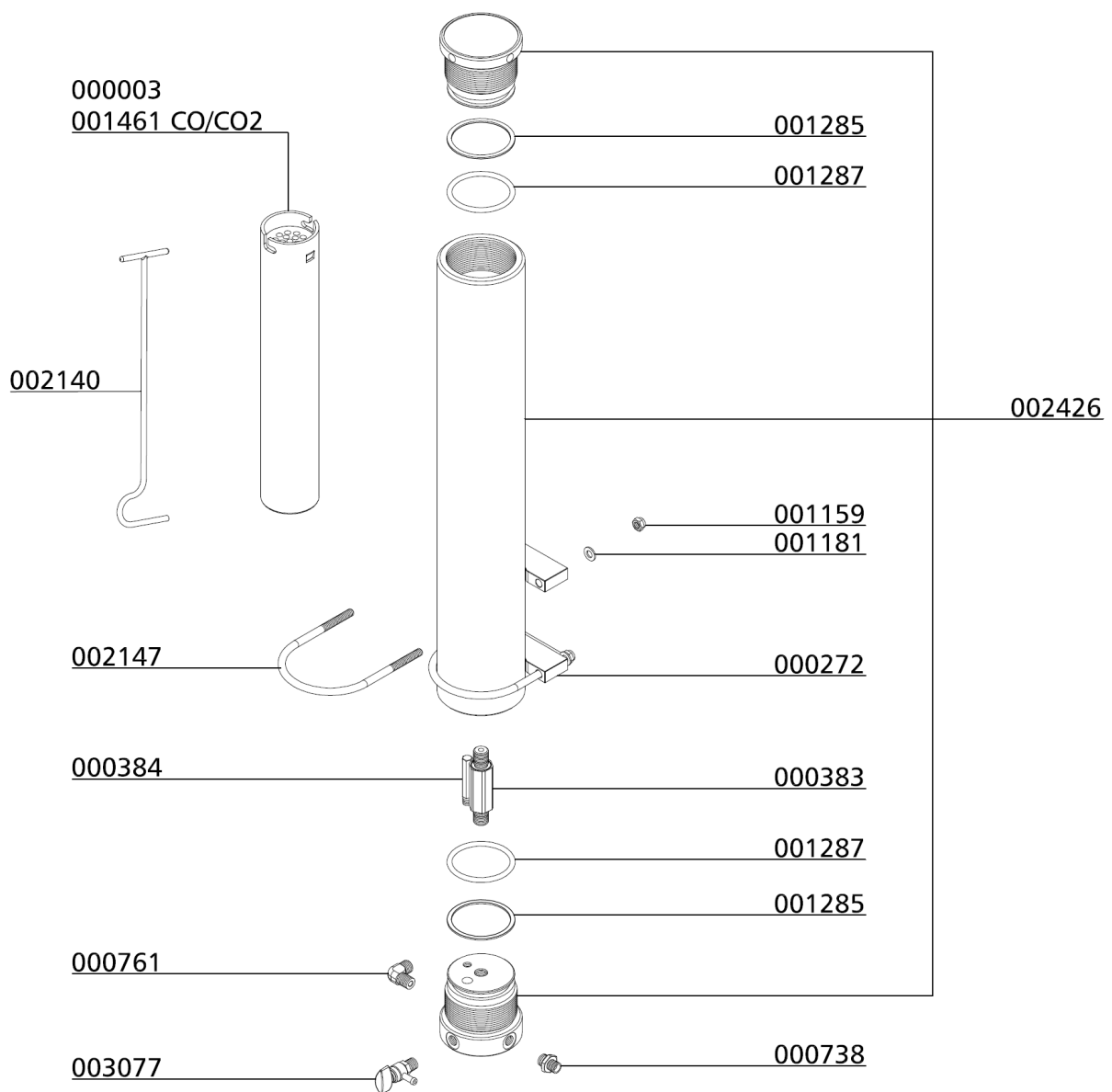

D

MAINTENANCE AND SERVICE

Filter housing

The mole carbon filter housing is installed on the right hand side of the compressor housing.

Inside the filter housing a jet blows air on to the housing wall. Condensation water and oil are led by centrifugal force to the bottom of the housing. Air flows through the mole carbon filter cartridge, which purifies the air from residual moisture and odours.

Filter cartridge

The high-pressure compressor is equipped with an integrated breathing air purification system. Air is compressed up to 330 bar, dried and odour- and tasteless purified. Oil residues are bounded. The breathing air filter cartridge consists of a molecular sieve and activated-carbon filter.

Cartridge capacity: approx. 2.3 l

All breathing air filter cartridges are factory vacuum sealed.

We recommend unpacking the filter cartridges just before installation. Filter cartridges which are exposed too long could be saturated with moisture and become unusable.

Maintenance intervals

Filter cartridges should be changed at the following intervals, at +20°C or more often, depending on humidity and ambient temperature:

- 35 hours



Filter housing

MAINTENANCE AND SERVICE

Filter cartridge change

Filter cartridge change as follows:

- Open the drain tab and vent the filter housing completely. (without automatic condensation drain)
- *Run the compressor up to a pressure of 100 bar. (with automatic condensation drain)*
- *Stop compressor. (with automatic condensation drain)*
- *Open filling valve. (with automatic condensation drain)*
- Unscrew filter housing cover by using the special filter tool (Fig. 1).
- Place the T-piece end of the filter tool in the recess of the filter cartridge (Fig. 2).
- Unscrew the filter cartridge anti-clockwise and pull the cartridge out of the housing (Fig. 3).
- Open the packing of the new filter cartridge and place it with the filter tool in the filter housing.
- Screw the new filter cartridge hand tight in by using the filter tool.
- Screw the cover of the filter housing first manually in.
- After it has been completely screwed in, turn cover anticlockwise for 90°. This avoids tightening of the cover due to vibration..

The filter cartridge change is now completed.



Note

Ensure that the old filter cartridge is disposed correctly at an approved waste point.



Fig. 1 - Unscrew the filter housing cover.



Fig. 2 - Place the T-piece end of the filter key in the top of the filter cartridge.



Fig. 3 - Pull the cartridge out of the housing.

MAINTENANCE AND SERVICE

Filter housing - maintenance



Note

Clean all parts thoroughly before assembly.

Filter housing maintenance as follows:

- Open Filter Cover (Fig. 1).
- Change o-ring and back-up ring, previously grease both (Fig. 2).
- Grease filter cover thread and close.

Dismount filter housing

- Loosen pipe connections and nuts (Fig. 3).
- Remove filter housing.
- Dismount filter housing base.
- Change o-ring and back-up ring, previously grease both (Fig. 4).
- Screw filter base tight in.

Mount filter housing

- Connect pipe connections and tighten.
- Adjust holding clamp and tighten nuts.

The filter housing maintenance is now completed.



Fig. 1 - Open Filter cover

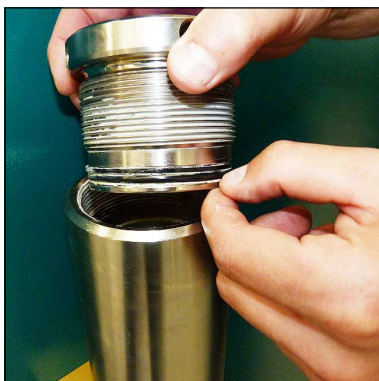

Fig. 2 - Change o-ring and back-up rings

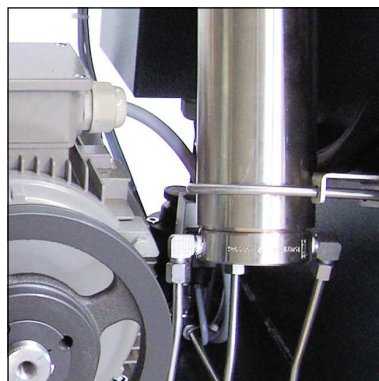

Fig. 3 - Loosen pipe connections and nuts



Fig. 4 - Change o-ring and back-up rings



**200 / 300 BAR
PARALLEL FILLING
PRESSURE OPERATION**

D

200 / 300 BAR PARALLEL FILLING PRESSURE OPERATION

200 bar / 300 bar parallel filling pressure operation

This option allows the filling of 200 bar and 300 bar at once.

In this case, the compressor is equipped with a pressure reducer, a second final pressure safety valve and a second filling pressure gauge.

The handwheels (or bellows) are colour-coded to allow an optical differentiation:

- 200 bar: black
- 300 bar: red

Furthermore, the corresponding filling pressures at the compressor are marked with labels.



DIN handwheels 200 bar and 300 bar

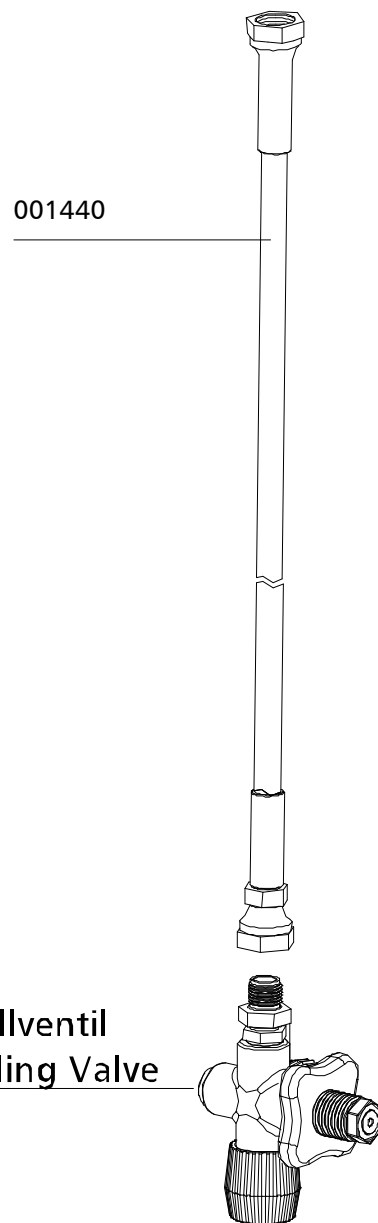

Fig. Safety valve: 225 bar (left),
pressure reducer: 330 / 225 bar (right)

200 / 300 BAR PARALLEL FILLING PRESSURE OPERATION

Füllschlauch / Filling Hose

Best.-Nr. / Order No.	Benennung	Description
001440	Hochdruckschlauch 10L, 1500 mm, starr	HP-Hose 10L 1500 mm, fixed



D



200 / 300 BAR PARALLEL FILLING PRESSURE OPERATION

Füllventil mit Manometer / Filling Valve with Pressure Gauge

Best.-Nr. / Order No.	Benennung	Description
000213	Handrad, schwarz, 200/232 bar DIN, G 5/8"	Hand Wheel DIN 200 bar, black, G 5/8"
000215	Handrad rot, 300 bar DIN	Hand Wheel DIN 300 bar, red
000386	Gleitscheibe, Kreuzventil	Slide Washer
000387	Feder, Kreuzventil	Coil Spring, cross d. valve
000666	Manometerschutzkappe Ø63mm	Protector Pressure Gauge Ø63mm
000696	Füllanschluss o. Handrad, Messing verchr., 200 bar, AG M16x1,5	Filling Connect. w/o handwheel. 200 bar, AG M16x1,5
000697	Füllanschluss o. Handrad, ab 2005, 300bar,AG M16X1,5 für Schlauch	Filling Connec. w/o handwheel, 300bar, AG M16X1,5 hose
000709	Füllventil Kreuzbauweise, v2 x G1/4" IG, 1 x M16 x 1,5mm IG	Filling Valve cross design
000785	Verschraubung konisch, GE 10L R1/4"	Connection conical, GE 10L R1/4"
001237	O-Ring DIN Flaschenanschluss 200/300bar, 12,37x2,62 NBR90	O-Ring DIN filling connector 200/300bar, 12,37x2,62 NBR90
001391	O-Ring, Kreuzventil	O-Ring, / Cross design Filling Valve
001392	Füllhandrad Kreuzventil Ø35mm	Hand Wheel Filling Valve cross Ø35mm
001393	Entlüftungsspindel	Vent Spindle
001394	Entlüftungshandrad Ø27mm	Vent Hand Wheel Ø27mm
001395	Gleitscheibe, schwarz, Kreuzventil	Slide Washer, plastic black
001397	Kupferdichtung 8 x 14 x 1mm	Copper Seal Ring 8 x 14 x 1mm
001398	Madenschraube M3x8mm	Worm Screw M3x8mm
001399	Adapterwelle, Kreuzventil	Adapter Shaft
001400	Dichtspindel, Kreuzventil	Seal Spindle Filling Valve
001401	Schlitzmutter	Slotted Nut
001402	Klemmverschraubung, kompl. mit O -Ring	Filling Spindle Body, c/w O-rings
004977	Manometer, Edelstahl	Pressure Gauge, S/S

D

200 / 300 BAR PARALLEL FILLING PRESSURE OPERATION

Füllventil mit Manometer / Filling Valve with Pressure Gauge

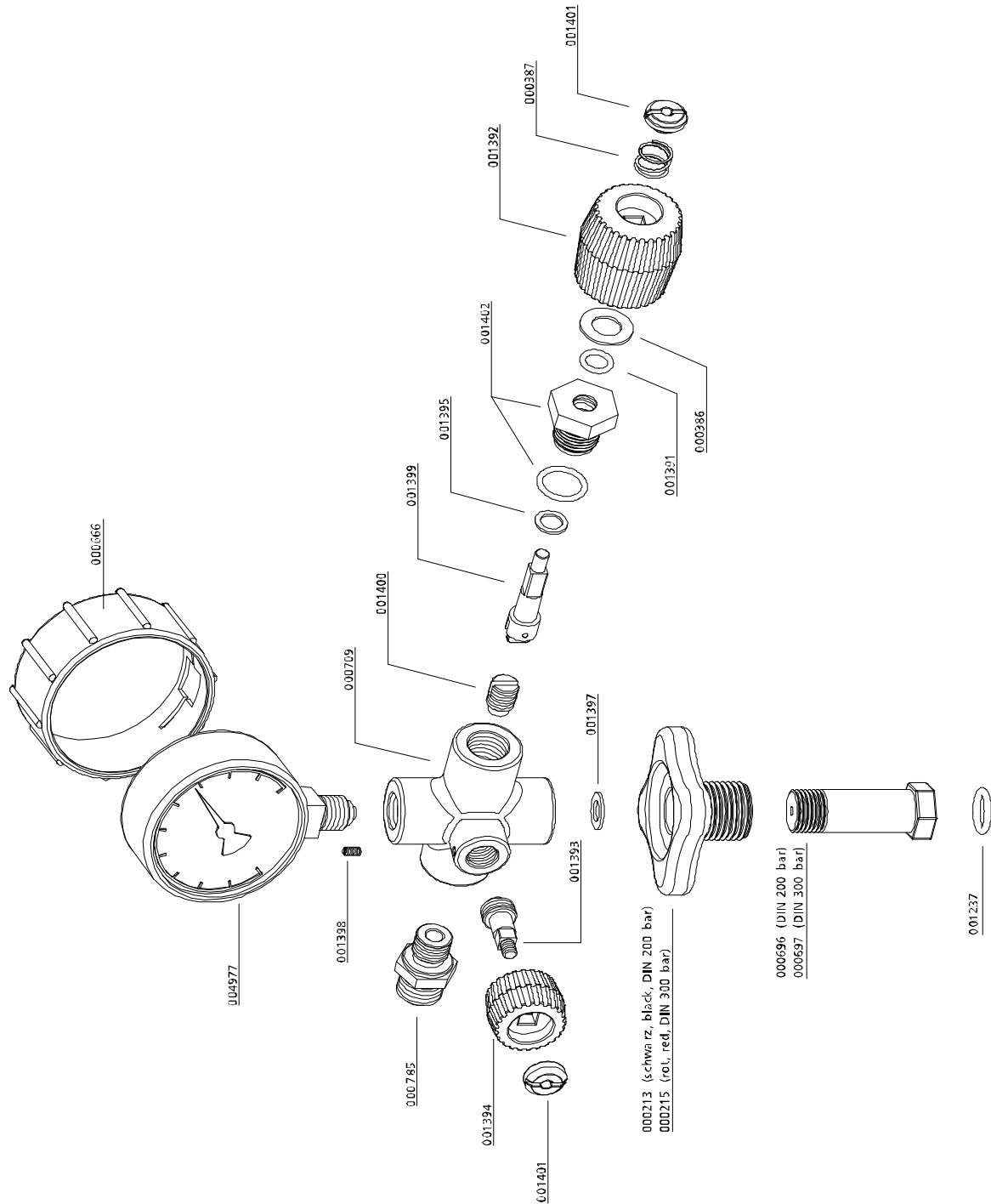

D



200 / 300 BAR PARALLEL FILLING PRESSURE OPERATION

Baugruppe: Verteilerblock / Assembly: Distributor Block

Best.-Nr. / Order No.	Benennung	Description
000210	Verteilerblock, Al, 2 Druckbereiche	Distributor Block, alloy, dual pressure
000498	Unterlegscheibe A6	Washer A6
000710	Verschraubung ohne Mutter &	Connection w/o nut& olive seal,
000721	Verschraubung WE 06 PLR CFX 1/4"	Connection WE 06 PLR CFX 1/4"
000732	Mutter M06LCFX	Union Nut M06LCFX
000733	Schneidring SR06	Olive Seal SR06
000738	Verschraubung GE 08 PLR1/4"	Connection GE 08 PLR1/4"
000750	Verschraubung, EVGE 08 PSR-ED / G1/4	Connection with fixed nut, EVGE 08 PSR-
000761	Verschraubung WE 08 PLR CFX 1/4"	Elbow connection WE 08 PLR CFX 1/4"
000765	Schneidring PSR 08 LX	Olive Seal PSR 08 LX
000767	Mutter M08 S A3C	Nut M08 S A3C
000838	Verschlussstopfen VSTI R1/4" EDCFX	Plug VSTI R1/4" EDCFX
001048	Zylinderschraube M6x10 DIN 912 8.8 ZN	Allen Screw M6x10 DIN 912 8.8 ZN
001428	Druckminderer "High Flow" einstellbar	Pressure reducer - bolt version
003182	Rohrleitung	Pipe
004932	Verschraubung MAV 1/4"NPT / 8S, für	Connection MAV 1/4"NPT / 8S, for

D

200 / 300 BAR PARALLEL FILLING PRESSURE OPERATION

Baugruppe: Verteilerblock / Assembly: Distributor Block

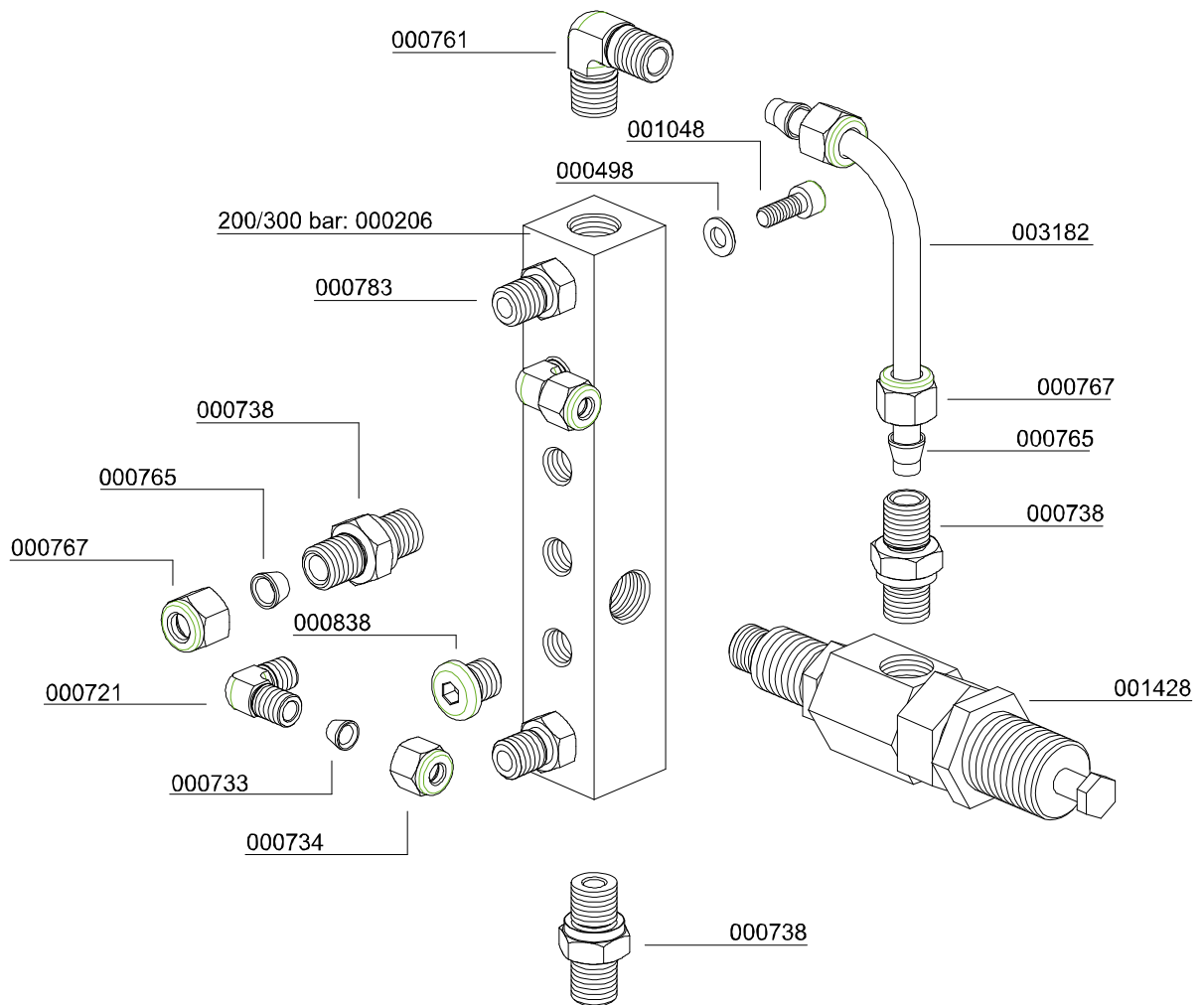

D



AIR COOLER CONNECTION KIT

D

AIR COOLER CONNECTION KIT

Air cooler connection kit

The Air Cooler Connection Kit provides an easy connection and a simple and time-saving installation or backfitting.

The piping inside the compressor is completely installed. Just disconnect the U-connection at the outside and connect the air cooler according to the connection designation (inlet/outlet).

To operate the unit without air cooler, reinstall the U-connection and the compressor is ready for use.

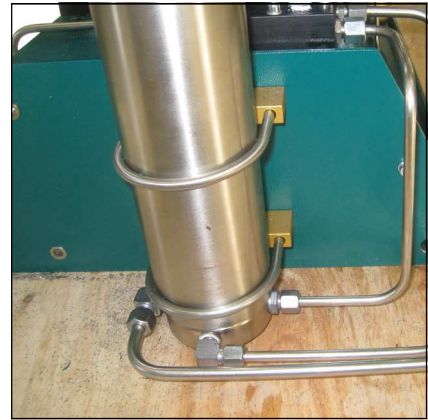

Air cooler connection kit

AIR COOLER CONNECTION KIT

Spare part lists

Best.-Nr. / Order No.	Benennung	Description
000783	Gerade Verschraubung	Straight Connection
000796	Winkelverschraubung	Elbow Connection
006928	Rohrleitung	Connecting Pipe

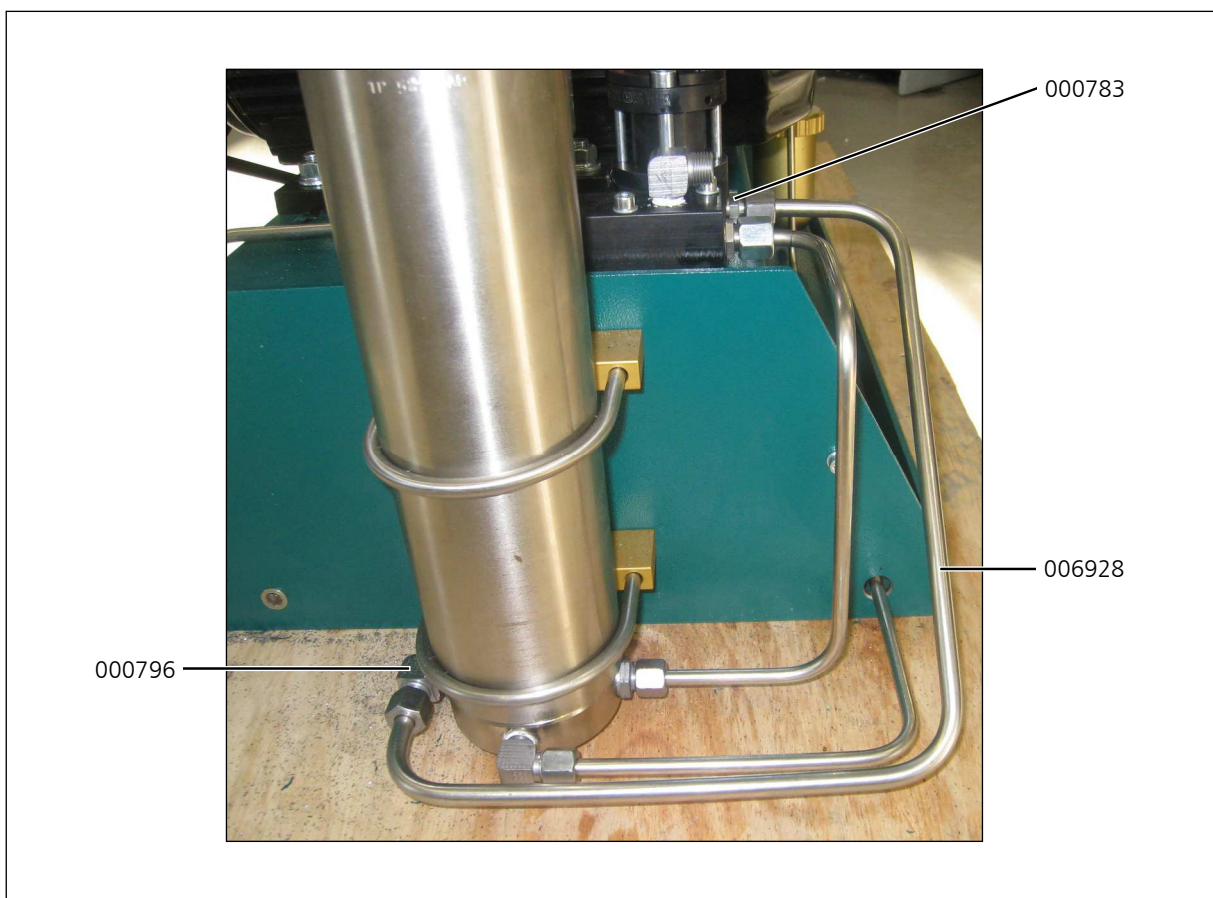

D



PHASE MONITORING

D

PHASE MONITORING

Phase Monitoring

With this option the direction of rotation is controlled by a phase monitoring system during the operation.

If the compressor is incorrectly connected the power supply does not allow to start the machine. In this case the red warning lamp will indicate the problem. A changing of the direction of rotation is inevitable then.

Another advantage is the control during the operation. In case of dissolving a phase, the compressor will shut-down automatically. The red warning lamp will indicate to this after shut-down directly.



Phase Monitoring



PHASE MONITORING

Spare Part List

Best.-Nr. / Order No.	Benennung	Description
004701	Warnlampe	Warning Lamp
004704	Relais für Warnlampe	Relais for warning lamp
006859	Schildträger	Label holder
008551	Einlegeschild Phasenüberwachung	Label Phase Control

D

PHASE MONITORING

Spare Part List

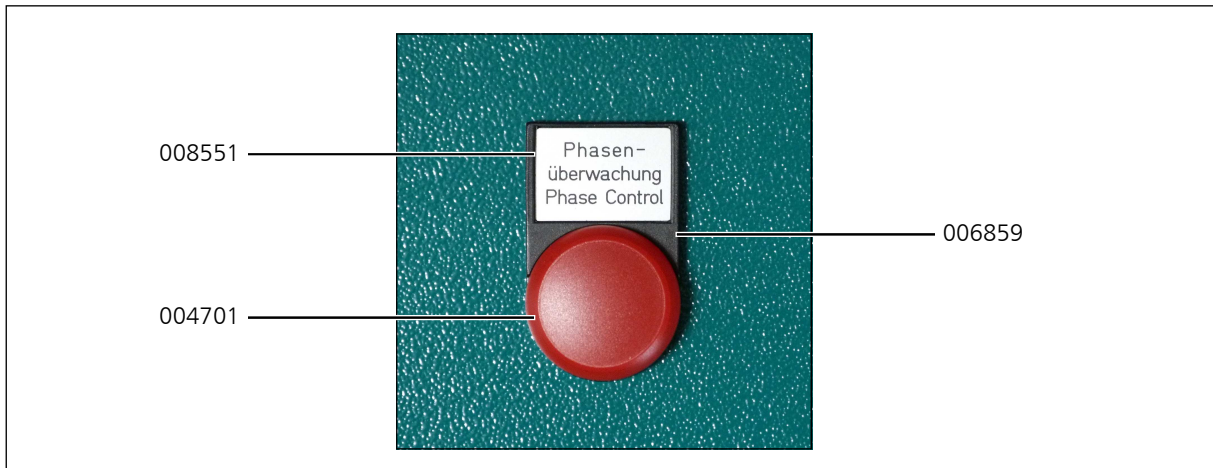

D

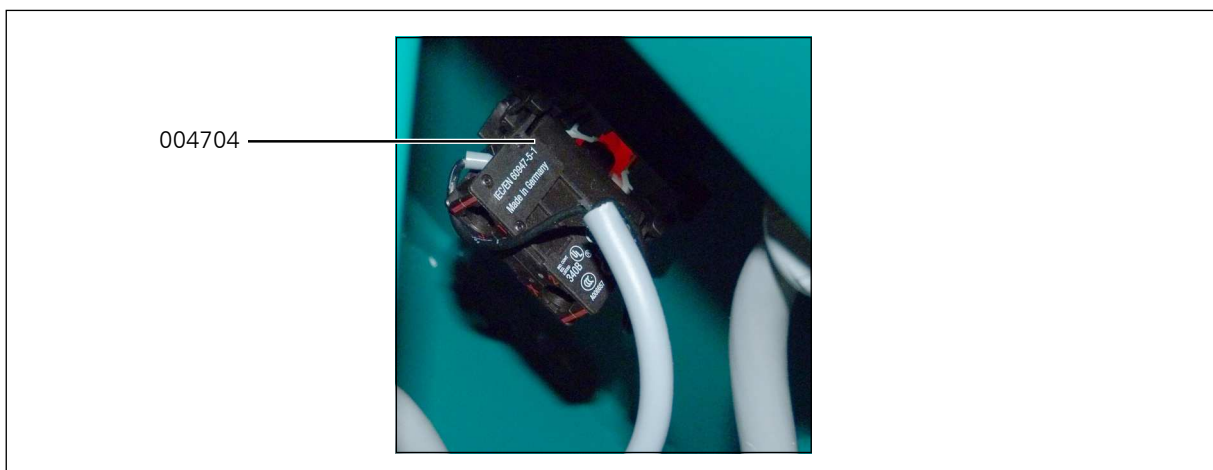



CONDENSATE TANK 60 LTR.

D

CONDENSATE TANK 60 LTR.

The 60 ltr. tank is equipped with an active carbon filter to collect condensate odourlessly and quietly. The condensate can be easily transported in the collecting tank and disposed environmentally sound.

The flexible connection hoses are fitted with quick-couplings, to allow easy separation from the compressor. The tank is equipped with a level gauge to indicate max. filling level. Two sturdy carrying handles ensure a safe transportation.

Technical Data:

- Dimensions: Ø 400 mm x 800 mm
- Weight: 20 kg



D

CONDENSATE TANK 60 LTR.

Maintenance and service

How to change the activated carbon and the metal filter insert

- Shut down the unit
- Plug out the condensate hoses
- Remove the protector cap, the nut and the allen bolts (Fig. 1)
- Take down the cover plate and the upper felt. Tip out the activated carbon and replace the lower felt
- Fill up the activated carbon and cover it with a new felt
- Put on the cover plate, screw the allen bolts and the nut and plug on the protector cap
- Unscrew the filter housing
- Remove the floater and the lower cover plate (Fig. 2)
- Take a pliers and pull the metal filter out of the metal case
- Insert the metal filter
- Install the cover plate and the floater
- Screw the filter housing onto the tank
- Plug in the condensate hoses

Maintenance intervals

We recommend to change the activated carbon if it has reached the saturation level (smell of oil).

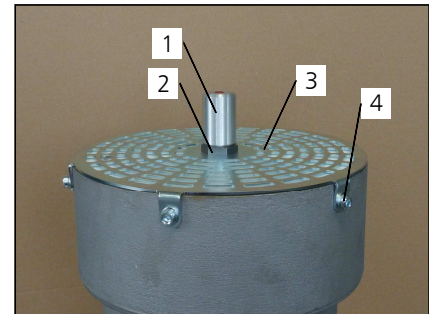

Fig. 1

- 1 Protector cap
- 2 Nut
- 3 Cover plate
- 4 Allen bolts (6x)

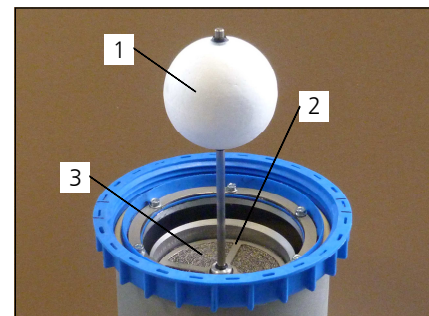

Fig. 2

- 1 Floater
- 2 Lower cover plate
- 3 Metal filter

CONDENSATE TANK 60 LTR.

Spare part lists

Best.-Nr. / Order No.	Benennung	Description
003091	Kondensatbehälter 60 Liter	Condensate Tank 60L
004056	Kondensatschläuche Kondensatbehälter 60L, für 3-	Set of condensate hoses, 3 stages
004057	Kondensatschläuche Kondensatbehälter 60L, für 4-	Set of condensate hoses, 4 stages

D

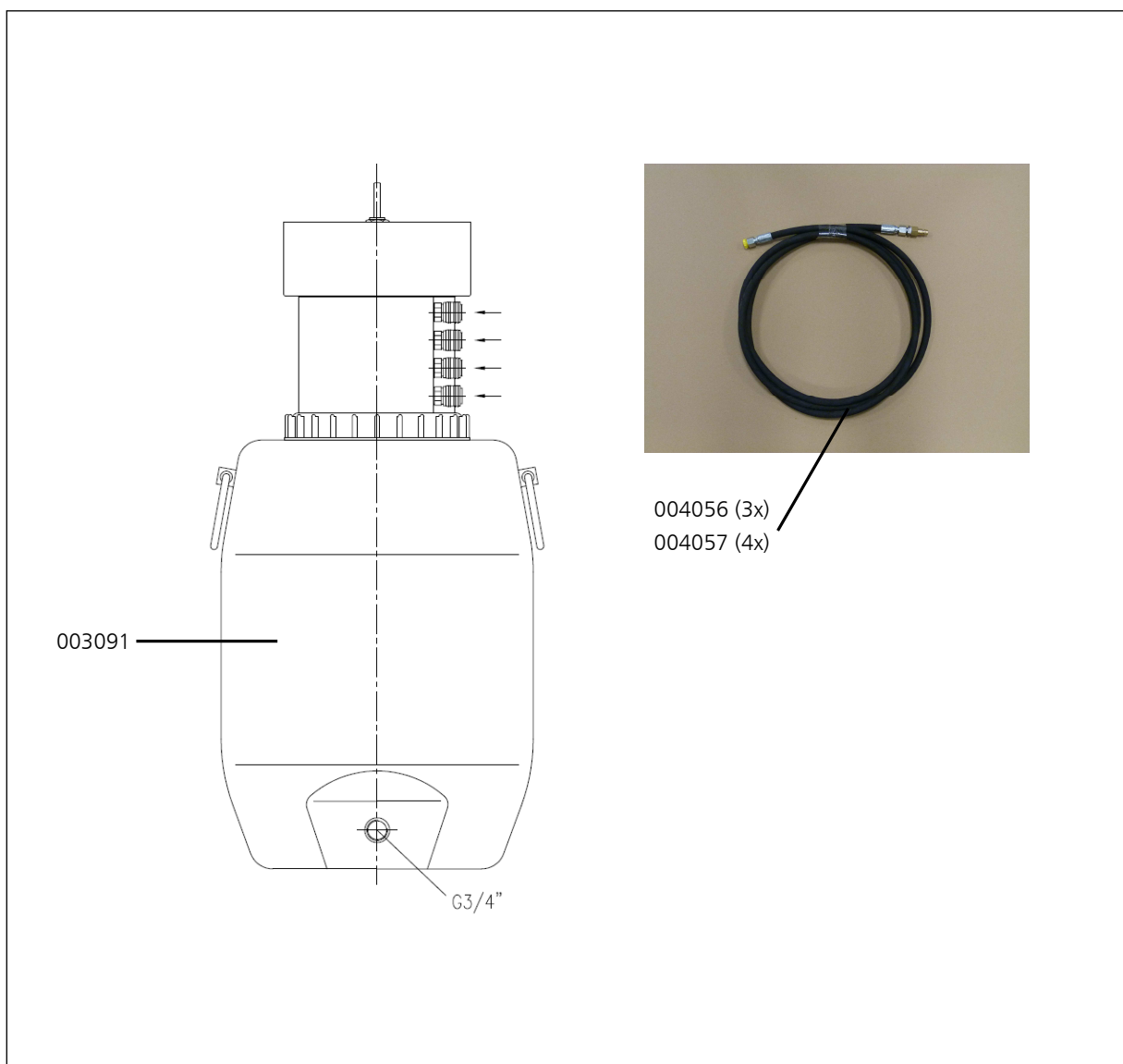

CONDENSATE TANK 60 LTR.

Spare part lists

Best.-Nr. / Order No.	Benennung	Description
000508	USIT-Ring 13,7 x Ø20 x 1,5	Gasket Ring U-Sit 13,7 x Ø20 x 1,5
003866	Filter Nachfüllset für 60 Liter	Filter refill set 60 ltr
004789	Schnellkupplung G1/4", DN 7,2	Quick connector G1/4", DN 7,2
006642	Metallgestrick für Kondensatbehälter 60 ltr	Metal filter insert 60 ltr tank

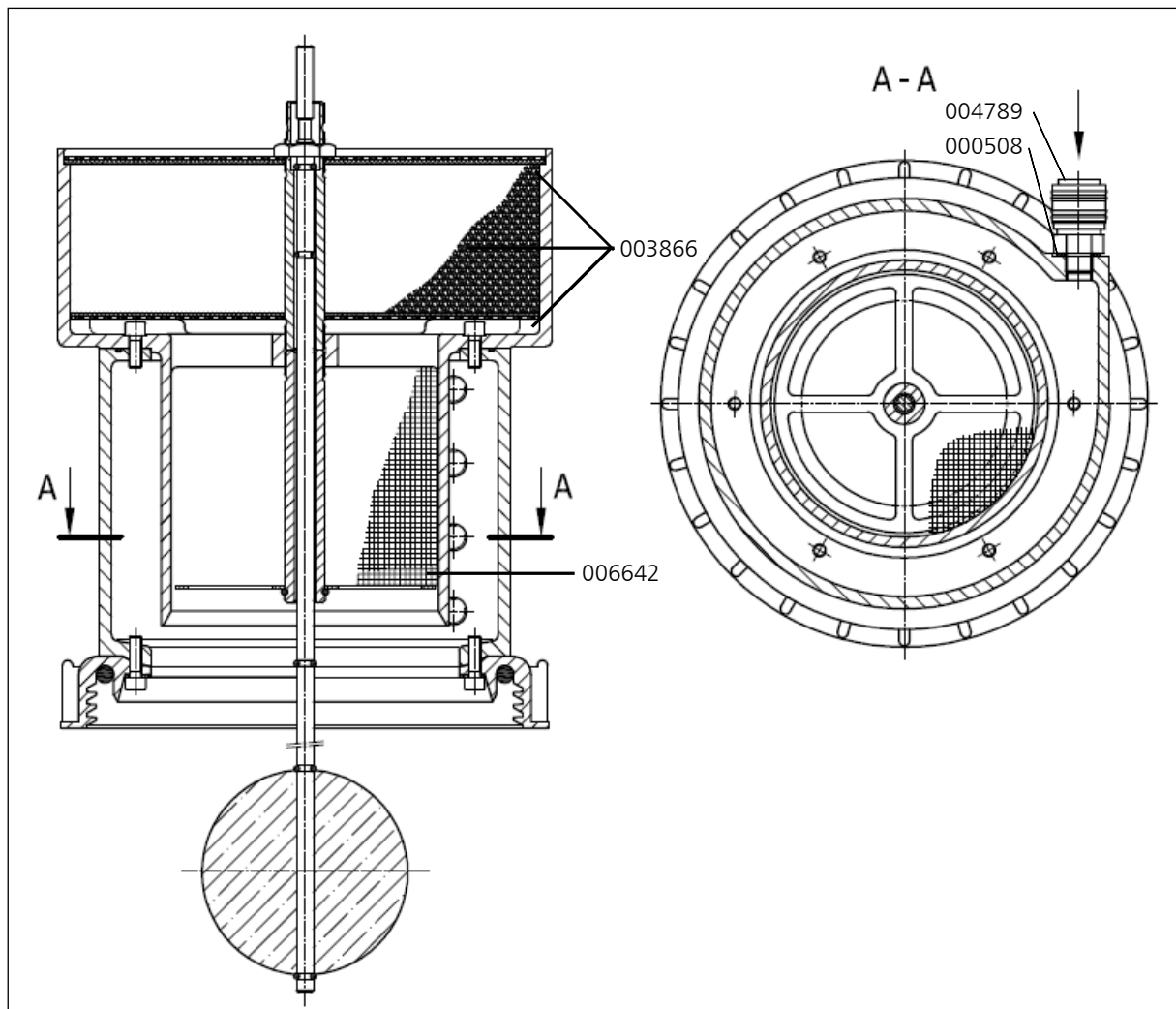

D



ATTACHMENT

E

Lenhardt & Wagner GmbH

**An der Tuchbleiche 39
D-68623 Lampertheim – Hüttenfeld**

www.lw-compressors.com



Operating Instruction

Safety valve

Typ:

SiV2 BKZ 989 TÜV.SV.12-989.5.G.V.P CE 0091 AlMgSi1 F31 1100* Lenhardt & Wagner

SiV BKZ TÜV.SV.14-1140.5.G.V.p CE 0091 AlMgSi1 F31 1100* Lenhardt & Wagner

Set pressure:	see mark (hand wheel on top of valve)
Maximum outflow:	Set pressure 100-159 bar: 750 l / min Set pressure 160-350 bar: 1.100 l / min
Suitable media:	Media-resistant, non-corrosive gases

The safety valve is used for protection of pressurized components, eg pipelines, pressure vessels, or the compressor itself.

The hand wheel on the top of the safety valve is marked with the adjusted set pressure.



- 1) Identification of set pressure
- 2) Seal
- 3) Fixing screws¹
- 4) Venting screw (hand wheel)
- 5) Identification serial number
- 6) Socket for safety valve

Safety valve with socket

¹ und die Anforderungen des AD 2000 Merkblatts W7 erfüllen. Schaftlänge 70mm. The fixing screws M8 must be strength class 8.8 and meet the requirements of Merkblatt AD 2000 leaflet W7. Shaft length 70mm.

In order to prevent manipulation of the set pressure, all safety valves are factory fitted with a seal.

A safety valve on which the seal has been removed, must be returned before further use to the manufacturer for repair / adjustment.

In addition, the safety valve has a venting device (hand wheel).

In the rotation direction clockwise, the safety valve and herewith also the filter housing of the final stage could be completely vented.

During normal operation, the screw is unscrewed to the upper stop anticlockwise, an integrated safety ring prevents that the screw can be completely unscrewed.

If a safety valve blow off, the system must be switched off immediately and investigate the cause of the error.

There are two possible reasons:

1. The safety valve is defective and blows off before the set pressure.

In this case the safety valve should be submitted immediately to the manufacturer for repair or replaced with a new one.

2. The safety valve opens properly, the problem is on the system.

A constant blowing of the safety valve is not permitted, the sealing seat of the valve can be damaged. The error on the system must be detected and repaired before further filling operations.

The safety valve may only be used if it is ensured that the maximum flowrate of the system does not exceed the blowoff rate of the safety valve.

The safety valve may only be used with the approved media.

Repair work on compressors must only be performed by trained personnel.

Dismantling of the safety valve

Ensure that on the safety valve is no pressure.

Loosen and remove the two M8 fixing bolts with a 6mm Allen key.

The safety valve can now be removed by turning and simultaneously pulling out of the socket.

Mounting

1. Clean the safety valve socket.

2. Oil the insert pin of the safety valve including the O-ring with 1 to 2 drops of oil.

3. Press the safety valve pin complete into the socket.

4. Fasten the safety valve with the two 8 mm allen screws into the socket

(Tightening torque: 10 Nm)

5. Screw the venting screw (hand wheel) anticlockwise to its upper limit.

6. Start the System (Compressor), check installation for leaks and proper function.

Manufacturer: Lenhardt & Wagner GmbH
An der Tuchbleiche 39
D-68623 Lampertheim – Hüttenfeld

Kontakt: E-Mail: service@lw-compressors.com
Web: www.lw-compressors.com
Tel.: +49 (0) 6256 – 85880 0
Fax: +49 (0) 6256 – 85880 14

Note:

*Use the safety valve only in a technically perfect condition, for its intended purpose, safety and danger awareness, in compliance with the operating instructions!
Especially disorders which could affect safety must be remedied immediately!*

Notes:

- The safety valve must be installed directly on the protected pressure vessel and / or the plant.
 - The safety valve must be installed in an upright position.
 - The flow area of the port must be greater than the valve opening.
 - Protect valve against splashes
-

Maintenance:

- The safety valve is periodically - in accordance with the currently valid Pressure Equipment Directives - to check on operation and reliability.
- Refill annually lubricating oil:
Oil filling position:
Hole on the spacer (see arrow, Figure 1)
- Oil level: Fill oil into the hole until oil comes out of the hole.

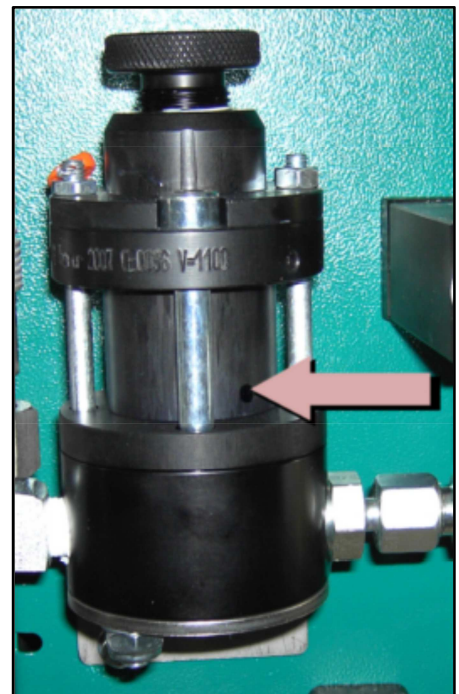

Figure 1: Position for oil refill

To be used lubricating oil for the safety valve: L&W Article Nr.: 008500 (content: 30 ml)
