



CHAPTER OVERVIEW

Operating Instructions

A

Technical Data Sheet

B

Spare Parts Lists

C

Options (if equipped)

D

Attachment

E

Manufacturer in terms of 97/23/EC

The full name and address of the manufacturer is:

Lenhardt & Wagner GmbH

An der Tuchbleiche 39

68623 Hüttenfeld / Germany

Phone: +49 (0) 62 56 - 85 88 0 - 0

Fax: +49 (0) 62 56 - 85 88 0 - 14

E-Mail: service@lw-compressors.com

Internet: www.lw-compressors.com





SERVICE INFORMATION / WARRANTY

Compressor information

Type designation

Serial number

Date of construction

Purchase information

Purchase date

First commissioned on

Warranty period

Dealer's stamp

Warranty

L&W will uphold warranty claims made during a period of 12 months from the invoice date.

If the compressor was purchased from an official L&W dealer, the date on the dealer's invoice is valid. Warranty claims can only be made on presentation of the original invoice.

Should verifiably defective parts have been delivered, we will decide to either replace the parts or repair them. The resulting transport and assembly costs will be invoiced.

No reduction of the purchase price or changes to the contract can be made. The parts for which a claim is being made should be kept safe by the purchaser and, when requested, sent to us at their cost. Replaced parts become the property of L&W. If maintenance work is carried out without our knowledge or permission by the purchaser or a third party, we are absolved from any liability for warranty claims. As a matter of principle, warranty claims can only be made by the initial purchaser.

Operating Instructions

Breathing Air Compressor

LW 300 D MC

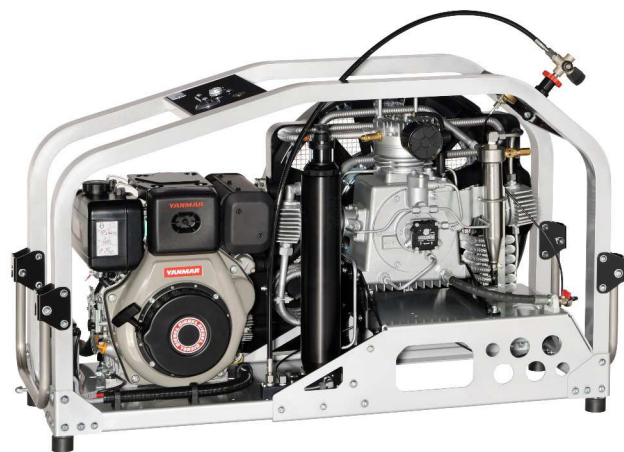



TABLE OF CONTENTS

General Information and Technical Data

General Information / Description of Warning Symbols	4
Scope of Delivery	5
Technical Data	6
Unit Assembly	7
Start Device	8
Flow Chart	9

Safety Precautions

Intended Use / Operators	11
Safety Instructions on the Unit	12
General Safety Precautions	13
Unit Customised Safety Notices	14
Maintenance Instructions	15
Transportation Instructions / Safety Regulations	16

Installation

Outdoor Installation	18
Dimensions	19
Minimum Distances	20
Ventilation	21
Electrical Installation	22 - 23

Operation

Important Operation Instructions	22
First Commissioning	23 - 25
Daily Commissioning	26
Filling Procedure	27
Switch off the Compressor	28

Remedying Faults	30 - 33
-------------------------------	---------

Maintenance and Service

Service, Repair and Maintenance	35
Maintenance Lists / Maintenance Intervals	36 - 39
Service Kits	40
Check V-Belt Tension / Tension V-Belt	41
Compressor Lubrication / Check Oil Level	42
Check Oil Level	43
Oil Change	44
Oil Sieve Change	45
Oil Filter Maintenance	46

A



TABLE OF CONTENTS

Maintenance and Service

Manuele Condensation Dump System	47
Oil / Water Separators 2nd Stage - Maintenance	48
Filter Housing / Filter Cartridge	49
Filter Cartridge Change LW 300 D MC	50
Filter Cartridge Change LW 300 D MC (Option)	51
Filter Housing - Maintenance	52
Inlet Filters / Inlet Filter Cartridge Change	53
Cylinder Heads and Valves	54
Fan Protection Cover Dismantling / Mounting the Fan Protection Cover	55
Replace Inlet and Outlet Valve 1st Stage	56 - 57
Replace Inlet and Outlet Valve 2nd Stage	58 - 59
Replace Inlet and Outlet Valve 3rd Stage	60
Safety Valves	61
Pressure Maintaining / Non Return Valve	62
Adjust Pressure Maintaining Valve	63
O-Rings—Filling Valve and Filling Hose	64
Test of Pressure Equipment	65
Maintenance Records	67 - 71

Storage

Conservation / Storage of the Compressor	72
De-Conservation, Commissioning	72
Transportation Instructions / Disposal	73

A

GENERAL INFORMATION

General Information

We strongly recommend reading this manual thoroughly prior to operation and follow all the safety precautions precisely. Damage resulting from any deviation from these instructions is excluded from warranty and liability for this product. Carry out other commissioning steps only if you have fully understood the following contents.

Before commissioning and using the unit, carry out all the essential preliminary work and measures concerning legal regulations and safety. These are described on the following pages of this operation manual.

A

Description of Marks and Warning Signs

The following warning signs are used in this document to identify the corresponding warning notes which require particular attention by the user. The warning signs are defined as follows:



Caution

Indicates an imminently hazardous situation which, if not avoided, could result in serious injury, physical injury or death.



Warning

Indicates a potentially hazardous situation which, if not avoided, could result in physical injury or damage to the product or environment.



Note

Indicates additional information on how to use the unit.



DESCRIPTION

Scope of Delivery

The new MC Series from L&W has been created for dive centers, ships, boats and places with limited space. These are suitable for continuous operation and guarantee low maintenance costs due to long service intervals. Comes ready to start. A super lightweight aluminum frame enables mobile applications, combined with very high filling capacity.

A

Versions

Filling pressure versions:

- PN 225 bar
- PN 330 bar
- PN 225 / 330 bar

Specifications

- Diesel Engine
- Painted lightweight aluminium frame in RAL 7001
- Hour counter
- Manual condensate drain
- 2 x Filling hose c/w filling valve
- Pressure maintaining and non return valve
- All pistons c/w steel piston rings
- Low pressure oil pump
- Oil filter with bypass
- Oil- / Water separators after 2nd and 3rd stage
- Safety valves after each stage
- 3 x concentric suction/pressure valves
- Filling pressure to your choice (200 or 300 bar)
- Connections to your choice (DIN 200 bar or 300 bar, CGA 200 bar or 300 bar and INT)
- Breathing air purification in accordance to EN 12021
- 1.7 l filter system (Filter capacity 750 m³ at +20°C)

Options

- Automatic condensate drain incl. collecting tank
- Automatic stop at final pressure
- Additional filling hoses c/w filling valves
- 200 and 300 bar parallel filling pressures
- Switch Over Device 200+300bar
- Oil- and interstage pressure gauges
- Oil pressure monitoring c/w auto shut down
- Additional high pressure outlet
- Wheel set
- Air Cooler Connection Kit
- Puracon filter monitoring

DESCRIPTION

Technical Data



Technical Data	LW 300 D MC
Capacity [l/min]:	300
Max. Operating Pressure [bar]:	350
RPM [min ⁻¹]:	1300
Number of Pressure Stages:	3
Cylinder Bore 1st Stage [mm]:	Ø 95
Cylinder Bore 2nd Stage [mm]:	Ø 36
Cylinder Bore 3rd Stage [mm]:	Ø 16
Medium:	Compressed Air / Breathing Air
Intake Pressure:	atmospheric
Oil Pressure [bar]:	+2.5 (±0,5)
Oil Capacity [l]:	1,8
Intake Temperature [°C]:	0 < +45
Ambient Temperature [°C]:	+5 < +45
Drive Power [kW]:	7,4
Motor:	Yanmar - Diesel Engine
RPM Motor [min ⁻¹]:	3600
Start:	Electric start / Hand start
Noise level from a distance of 1 m [dB(A)]:	95,9
Dimensions L x W x H [mm]:	1410 x 510 x 826
Weight [kg]:	195
Content Volume Filter housing [l]:	0,54

DESCRIPTION

Unit Assembly

A

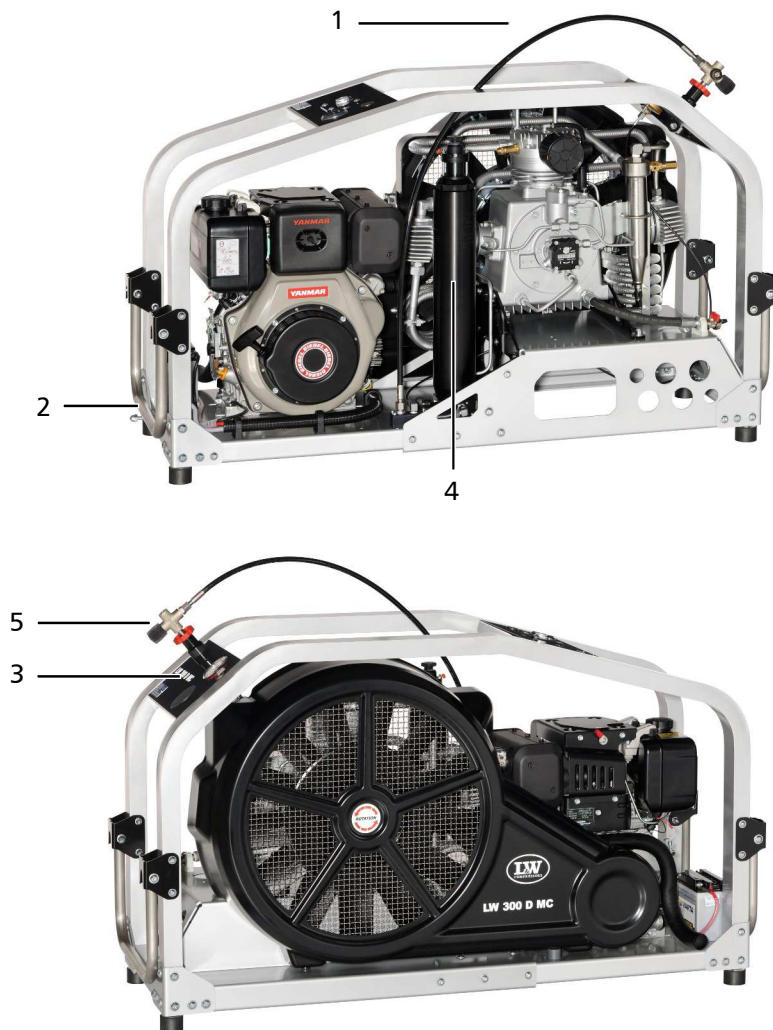

No.	Designation
1	Filling Hose
2	Carrying Handle
3	Final Pressure Gauge
4	Filter Housing
5	Filling Valve

DESCRIPTION

Start Device

A

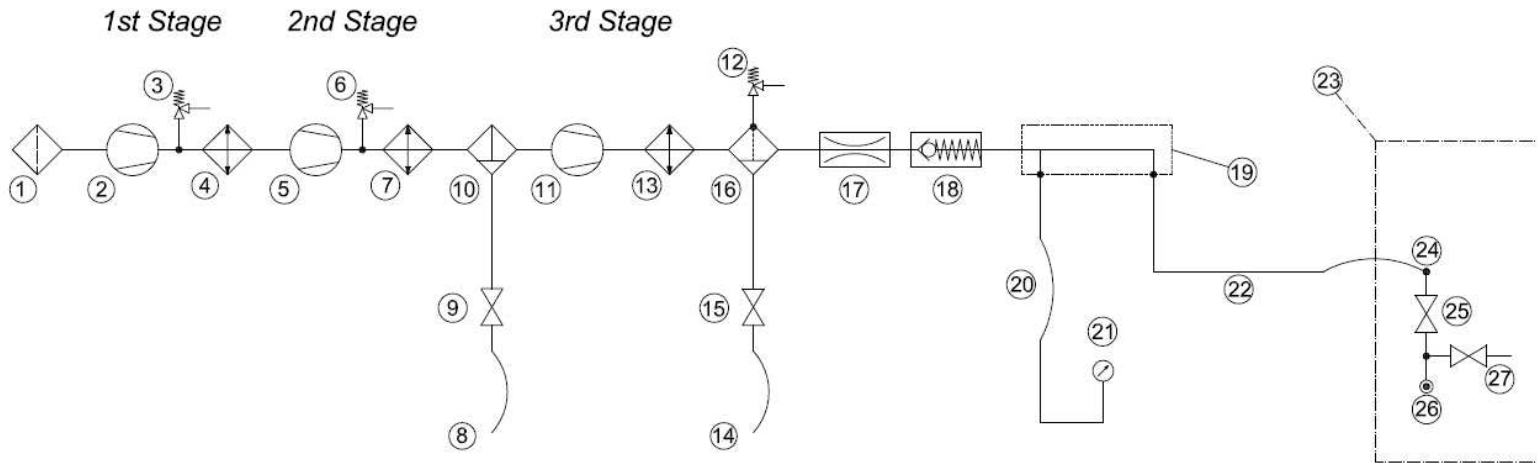

Fig. - Hand Start LW 300 D MC



Fig. - Key Switch LW 300 D MC

No.	Designation
1	Hand Start
2	E-Starter (Key Switch)



Flow Chart

DESCRIPTION

- | | | |
|-----------------------------|--------------------------------|---------------------------------------|
| 1. Air Intake Filter | 10. Oil-/Water Separator | 19. Distributor Block |
| 2. 1st Pressure Stage | 11. 3rd Pressure Stage | 20. Hose Pressure Gauge |
| 3. Safety Valve 1st Stage | 12. Endpressure-Safety Valve | 21. Pressure Gauge (Filling Pressure) |
| 4. Cooling Pipe 1st Stage | 13. Cooling Pipe Final Stage | 22. Filling Hose |
| 5. 2nd Pressure Stage | 14. Condensate Release Hose | 23. Unit Filling Valve "Cross Design" |
| 6. Safety Valve 2nd Stage | 15. Condensate Release Valve | 24. Plug 1/4" |
| 7. Cooling Pipe 2nd Stage | 16. Oil-/Water Separator | 25. Filling Valve |
| 8. Condensate Release Hose | 17. Pressure Maintaining Valve | 26. Filling Connector |
| 9. Condensate Release Valve | 18. Non-Return Valve | 27. Vent Valve |





A

SAFETY PRECAUTIONS



SAFETY PRECAUTIONS

Intended Use

Only use the unit in perfect condition for its intended purpose, safety and intended use and observe the operating instructions! In particular disorders that may affect safety have to be eliminated immediately!

Use the unit exclusively for the determined medium (see "Technical Data"). Any other use that is not specified is not authorized. The manufacturer/supplier shall not be liable for any damages resulting from such use. Such risk lies entirely with the user. Authorization for use is also under the condition that the instruction manual is complied with and inspection and maintenance requirements are enforced.

No change and modification to the unit can be made without the written agreement of the manufacturer. The manufacturer is not liable for damage to persons or property resulting from unauthorised modifications.

Operators

Target groups in these instructions;

Operators

Operators are persons who are authorized and briefed for the use of the compressor.

Qualified personnel

Qualified personnel are persons who are entitled to repair, service, modify and maintain the system.



Warning

Only trained personnel are permitted to work on the unit!



Warning

Work on the electrical equipment on / with the machine / unit may only be carried out by qualified electricians.

SAFETY PRECAUTIONS

Safety Instructions on the Unit

Importance of notes and warning signs that are affixed to the compressor according to the application or its equipment.

A



Warning
High voltage!



Note
Ensure correct direction of rotation!



Warning
Hot surfaces!



SAFETY PRECAUTIONS

General Safety Precautions

- Read the Operating Instructions of this product carefully prior to use.
- Strictly follow the instructions. The user must fully understand and strictly observe the instructions. Use the product only for the purposes specified in the intended use section of this document.
- Do not dispose the operating instructions. Ensure that they are retained and appropriately used by the product user.
- Only trained and competent personnel are permitted to use this product.
- Comply with all local and national rules and regulations associated with this product.
- Only trained and competent personnel are permitted to inspect, repair and service the product.
- Only authentic L&W parts and accessories may be used for maintenance work. Otherwise, the proper functioning of the product may be impaired.
- Do not use faulty or incomplete products. Do not modify the product.
- Inform L&W in the event of any product or component fault or failure.
- The quality of the air supply must meet EN 12021 specifications for breathing air.
- Do not use the product in areas prone to explosion or in the presence of flammable gases. The product is not designed for these applications. An explosion might be the result if certain conditions apply.

A



SAFETY PRECAUTIONS

Unit Customised Safety Notices

Organisational measures

- In addition to the instruction manual, observe and comply with universally valid legal and other obligatory regulations regarding accident prevention and environment protection.
- In addition to the instruction manual, provide supplementary instructions for supervision and monitoring duties taking into consideration exceptional factors e.g. with regard to organisation of work, production, personnel employed.
- Supervise personnel's work in accordance with the instruction manual, taking into account safety and danger factors.
- Observe all safety and danger notices on the compressor and check readability and completeness.

Safety instructions operation

- Take measures to ensure that the machine is only taken into operation under safe and functional conditions. Only operate the compressor if all protective and safety equipment, e.g. detachable protective equipment, are provided and in good working order.
- Check the compressor at least once per day for obvious damage and defects. Inform the responsible department / person immediately if anything is not as it should be (including operation performance). Shut down the machine immediately if necessary and lock it.
- In case of malfunction, stop the compressor immediately and lock it. Repair malfunctions immediately.
- If there is a failure in the electric energy supply, shut the machine / unit down immediately.
- Ensure safe and environmentally friendly disposal of consumables and old parts.
- The stipulated hearing protectors must be worn.
- Soundproofing equipment on the compressor has to be activated in safety function during operation.
- When handling with fats, oils and other chemical agents, observe the note for the product-related safety.

A



SAFETY PRECAUTIONS

Maintenance Instructions

- Hoses have to be checked by the operator (pressure and visual inspection) at reasonable intervals, even if no safety-related defects have been detected.
- Immediately repair any damage. Escaping compressed air can cause injury.
- Depressurise system and pressure lines before beginning repair work.
- Pressurised air lines must be laid and mounted by qualified personnel. Connections must not be mixed up. Fittings, length and quality of the piping must correspond to requirements.
- Adjustment, maintenance and inspection activities and keep appointments, including information on replacement parts / equipment, prescribed in the operating instructions have to be respected.
- If the machine / equipment is completely off during maintenance and repair work, it must be protected against unexpected restart. Turn off main control device and remove the key and/or display a warning sign on the main switch.
- The machine and especially the connections and fittings should be cleaned from oil, fuel and maintenance products at the beginning of the maintenance / repair. Do not use aggressive cleaning agents. Use fibre-free cleaning cloths.
- Switch off compressor and clean with a slightly damp cloth. Remove dirt from cooling pipes by using a brush.
- After cleaning, examine all pipes for leaks, loose connections, chafing and damage. Immediately eliminate any faults.
- Always retighten any screw connections loosened for maintenance or repair work.
- If it is necessary to remove safety devices for maintenance and repair work, these must be replaced and checked immediately after completion of the maintenance or repair work.
- The electrical equipment of the compressor must be regularly checked. Defects, such as loose screw connections or burnt wires, must be immediately rectified by electrically skilled personnel.
- Only personnel with particular knowledge and experience with pneumatics may carry out work on pneumatic equipment.
- Only personnel with particular knowledge and experience in gas equipment may carry out work on gas equipment.

A



SAFETY PRECAUTIONS

Transportation Instructions

- Parts which need to be dismantled for transport purposes must be carefully replaced and secured before taking into operation.
- The transport may only be carried out by trained personnel.
- For transportation, only use lifting devices and equipment with sufficient lifting power.
- Do not stand or work under suspended loads.
- Also separate from minor relocation machinery / system of any external energy supply. Before recommissioning, reconnect the machine to the mains according to regulations.
- When recommissioning, proceed according to the operating instructions..

Safety Regulations

- Inspections according to legal and local obligatory regulations regarding accident prevention are carried out by the manufacturer or by authorised expert personnel. No guarantees whatsoever are valid for damage caused or favoured by the non-consideration of these directions for use.

A



A

INSTALLATION

INSTALLATION

Outdoor Installation



Danger

Compressors with petrol or diesel motors must only be located outdoors, never indoors, not even in partially closed rooms however large they may be.

No operation in explosion-hazard areas.

The unit is not approved for operation in areas prone to explosion.

A

For outside installation observe the following:

- Install the unit horizontally and level. The floor must be vibration-free and capable of taking the load of the system weight.
- On units employing petrol or diesel motors, it is most important that only clean air is used. Position compressor in direction of wind so that exhaust fumes are blown away from the unit.
- Intake air must be free from noxious gas e.g. smoke, solvent vapours, exhaust fumes etc.
- Observe the specified operating temperature (see "Technical Data")!

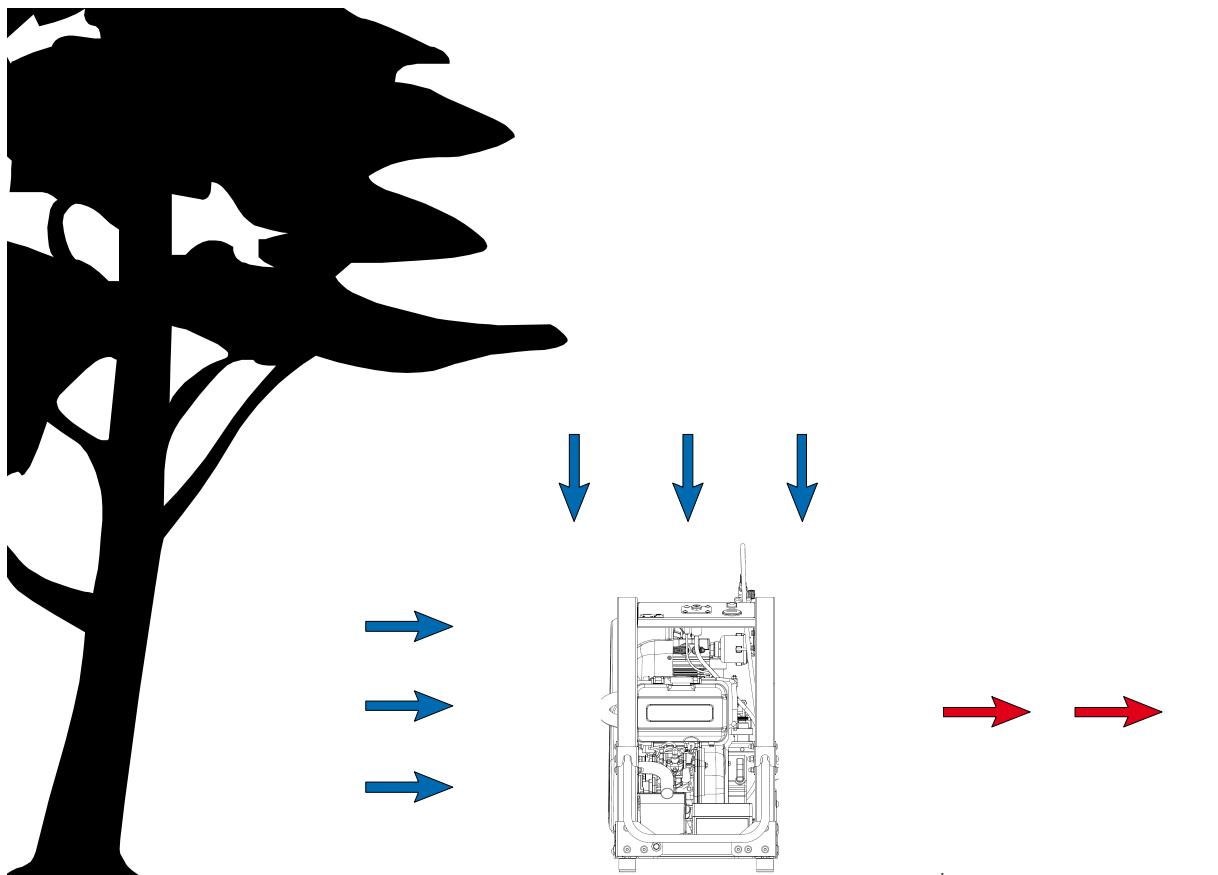

INSTALLATION

Dimensions

A

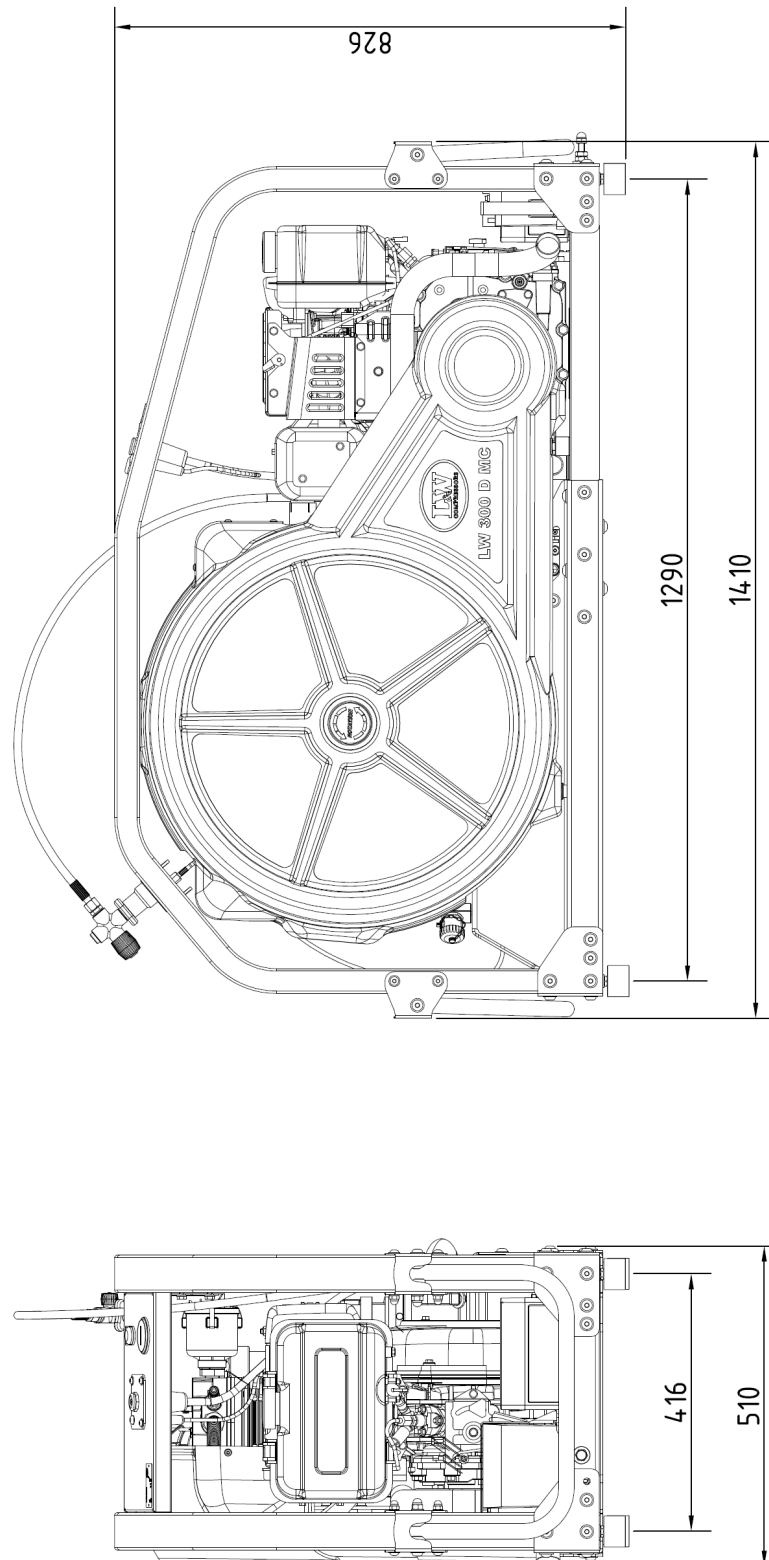

Fig. - Dimensions

INSTALLATION

Minimum Distances



Note

Minimum distances must be adhered!

- Make sure that the compressor always has a sufficient amount of fresh air available.
- To prevent serious damage, ensure that the cooling air flow can flow freely.
- The following minimum distances must be adhered:
Front side min. 1500 mm, sides min. 500 mm, rear side min. 500 mm.
Avoid anything in this area which can restrict the cooling air flow.

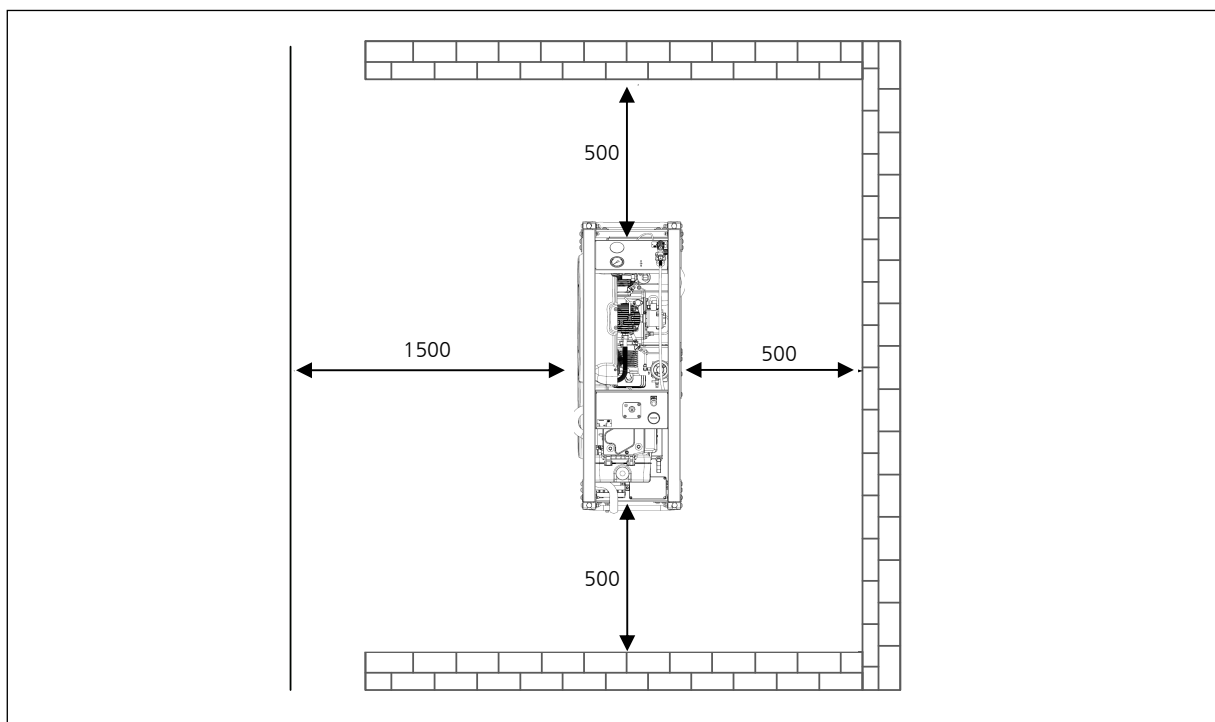

Fig. - Minimum distances



A

OPERATION



OPERATION

Important Operation Instructions



Danger

Compressors with petrol or diesel motors must only be located outdoors, never indoors, not even in partially closed rooms however large they may be.



Note

Ensure that all persons handling the compressor are familiar with function and operation of the unit.



Wear hearing protection

When working on a running machine, always wear hearing protection.

A



FIRST COMMISSIONING

Prior to first Commissioning, observe the following:

Necessary steps are described in the following.

- Ensure that cooling air can flow freely.
- Position compressor in direction of wind so that exhaust fumes are blown away from the unit.
- Take protection measures to avoid damages or injury by exhaust gases/exhaust pipe.
- Check fuel capacity.
- Check drive motor oil level.
- Check compressor oil level by using the oil dipstick (see page A-25).
- Check all connections and retighten if necessary.
- Check if the filter cartridge is in place (see "Service and Maintenance").
- Check the V-belt tension.
- Read carefully the handbook of the petrol engine.
- Check if all filling valves are closed. Open one filling valve and hold tight manually!

A

FIRST COMMISSIONING

Start the Compressor (LW 300 D MC)

1. Open condensate valves
2. Open fuel tap (Fig.3)
3. Open filling valve
4. Slide throttle lever (Fig.2)
5. Start the compressor with the key switch or hand start (Fig.1).
If the compressor should be started by the hand start, you have to move the decompression lever before.
6. Close condensate valves
7. Run the compressor for about 2 minutes
8. Close the open filling valve carefully
9. Run the compressor up to maximum pressure and check the function of the final pressure safety valve. If the compressor is equipped with an automatic stop system please check the automatic shut down at final pressure. If the final pressure switch does not shut off, switch off the compressor with the key switch (see chapter "Remedying faults").
10. Stop the compressor with the key switch
11. Close fuel tap
12. Check the compressor unit for leaks (see "Service and Maintenance")
13. Now check the condensate drain valves:
- If correct, air escapes of the condensate drain
14. Open all condensate valves and the filling valves carefully to vent
15. After venting close all condensate valves and the filling valves



Fig. 1 - Hand Start & E- Starter



Fig. 2 - Throttle lever

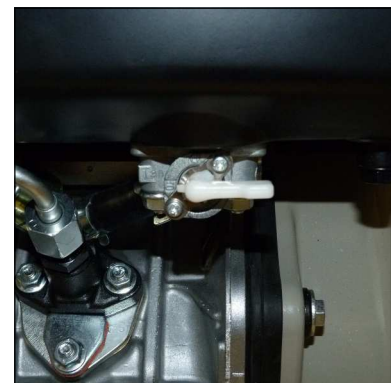

Fig. 3 - Fuel tap



Fig. 4 - Decompression Lever

A

FIRST COMMISSIONING

Check Oil Level



Warning

Check oil level daily. Never start the compressor with a too low oil level. Risk of accidental loss, destruction or deterioration.

Check the oil level before each operation of the unit by using the oil dipstick.

Oil level check as follows:

- Unscrew oil dipstick
- Wipe off oil residues
- Insert the oil dipstick back into its tube and screw it until stop
- Unscrew oil dipstick again

The oil level should be between the notch and the end of the oil dipstick. If there is no oil between the notch and the end of the oil dipstick, refill immediately new full synthetic compressor oil.



Fig. - Oil dipstick

Check V-belt tension

The V-belts could lose tension during transportation. Please check the V-belt tension before starting the compressor.

Tension V-belts

To tighten V-belt tension, loosen 4 mounting nuts of the drive motor. Use the tensioning screw to move the drive motor until the V-belt tension is sufficient (V-belt pulley and flywheel must be aligned). Then, tighten mounting nuts and check V-belt tension.

We recommend using a V-belt tension gauge.

Correct V-belt tension

Do not tension V-belts too tight. This damages bearings of compressor and motor. The V-belts should only be tensioned until there is no noise caused by slipping during start.

Settings

Motor Type	Initial Installation	Operation after running in
Drive Motor LW 300 D MC	500N	400N



DAILY COMMISSIONING

Prior to Daily Operation, observe the following:

- Ensure cooling air can flow freely.
- Position compressor in direction of wind so that exhaust fumes are blown away from the unit.
- Take protection measures to avoid damages or injury by exhaust gases/exhaust pipe.
- Check compressor oil level by using the oil dipstick.
- Check if filter cartridge is in place / observe filter cartridge life!
- Check fuel capacity.
- Check drive motor oil level.
- Ensure toxic-free, pure intake air.

A

OPERATION

Filling Procedure



Caution! Only fill cylinders which:

- are marked with the test mark and the test stamp of the expert.
- have been hydrostatic tested (check last test date).
- are rated for the final pressure.
- are free from humidity.



Note

The unit must be stopped manually when final pressure is reached. No serial auto shut down. The unit must also be started manually.



Caution

Vent condensate drain valves every 15-30 minutes manually.

1. Close all filling valves.
2. Connect the closed compressed air cylinders.
3. Open cylinder valves.
4. Start the compressor with hand start or key switch.
5. When filling pressure gauge increases, open filling valves slowly.
6. Fill the compressed air cylinders to the desired pressure; subsequently close the filling valves slowly.
7. Switch off the compressor.
8. Close and vent all filling valves.
9. Disconnect all compressed air cylinders from filling valves.
10. Open condensate drain valves manually.



OPERATION

Switch off the Compressor

The compressor unit is not equipped as standard with an auto shut down. The unit must always be stopped manually when final pressure is reached.

During filling process, the system can be shut down at every time by using the key switch or close the fuel tap.



Note

After switching off, open condensate drain valves manually to vent the unit.

A



A

REMEDYING FAULTS

REMEDYING FAULTS

Final pressure can not be reached

Cause of fault	Remedy
Connections leaky	Retighten or clean/replace if necessary
Final pressure safety valve leaky	Replace
Pipes / heat exchanger broken	Replace
Condensate drain valves leaky	Unscrew valves, check sealing surfaces, clean, replace if necessary
Final pressure switch stop unit	Verify settings, replace if necessary
Piston of pneumatic condensate valve sticks	Clean pneumatic condensate valve and restore function, check/replace o-rings, replace valve completely if necessary

Strong compressor vibration

Cause of fault	Remedy
V-belt tension too loose	Tension V-belt
Drive motor / Compressor unit loosely	Retighten mounting screws
Anti vibration mounts used up	Replace
Ground not levelled	Ensure a solid and level ground

Air supply too low

Cause of fault	Remedy
Inlet and outlet valves contaminated / defective	Clean, replace if necessary
Cylinder(s), piston(s) or piston ring(s) used up	Replace
V-belt slips	Tension V-belt
See chapter "Final pressure can not be reached"	See chapter "Final pressure can not be reached"

REMEDYING FAULTS

Compressor overheated

Cause of fault	Remedy
Inlet filter cartridge contaminated	Replace
Ambient temperature too high	Improve room ventilation /
Cooling air inlet and outlet insufficient	Observe minimum distances (see Installation Instructions)
Air intake hose too long	Reduce length of the air intake hose
Air intake hose diameter too small	Use a larger diameter
Wrong compressor rotation direction	Ensure correct phase rotation,
Inlet and outlet valves contaminated / defective	Clean, replace if necessary

Safety valve leaks

Cause of fault	Remedy
Inlet and outlet valves of the following pressure stage defective	Clean, replace if necessary
Sinter filter of the following water separator blocked	Replace
Safety valve leaky	Replace

Oil taste in the air

Cause of fault	Remedy
Mole carbon filter cartridge saturated	Replace
Compressor oil unsuitable	Use prescribed oil quality
Filter cartridge unsuitable	Use prescribed filter type
Cylinder(s), piston(s) or piston ring(s) defective	Replace

REMEDYING FAULTS

Automatic condensate drain defective

Cause of fault	Remedy
Solenoid coils defective	Replace
Cable / supply cable defective	Repair, replace if necessary
Timer / relais defective	Replace
Sinter filter of pneumatic condensate valve blocked	Replace
Piston of pneumatic condensate valve sticks	Clean pneumatic condensate valve and restore function, check/replace o-rings, replace valve complete if necessary

Condensate drain starts before reaching final pressure

Cause of fault	Remedy
Pressure stages are not as prescribed, control pressure of pneumatic condensate valve too low	Check corresponding inlet and outlet valve, replace if necessary.
Piston sealing of pneumatic condensate valve contaminated / used up	Clean, replace if necessary
Timer / relais settings not correct	Adjust as prescribed
Timer / relais defective	Replace

Compressor stops before final pressure

Cause of fault	Remedy
Final pressure switch settings not correct	Correct settings
Opening pressure of the pressure maintaining valve too high	Correct settings
Fuse / circuit breaker has tripped Valid only for E models	Check fusing of the power supply / observe regulations
Emergency stop switch has tripped	Unlock emergency stop switch, close compressor housing door correctly



REMEDYING FAULTS

Filter life not sufficient

Cause of fault	Remedy
Pressure maintaining valve settings not correct	Adjust as prescribed
Filter cartridge unsuitable	Replace by a prescribed filter cartridge type
Filter cartridge too old	Observe expiration date
Filter cartridge packaging incorrect / damaged / already opened. Filter cartridge already partly saturated before change	Store filter cartridges properly, dispose defective cartridges
Operating temperature too high	Ensure sufficient ventilation
Cylinder(s), piston(s) or piston ring(s) defective	Replace

Oil consumption too high

Cause of fault	Remedy
Cylinder(s), piston(s) or piston ring(s) defective	Replace
Compressor oil unsuitable	Use prescribed oil quality
Operating temperature too high	Observe prescribed operating temperatures
Oil leak at the compressor block	Tighten corresponding mounting screws, if necessary replace corresponding paper sealing / o-ring / shaft seal



A

MAINTENANCE AND SERVICE

Service, Repair and Maintenance

A



Note

The following maintenance work refers exclusively to the compressor or the compressor unit, not to the drive motor! Refer to the enclosed manual for drive motor maintenance!

Carry out service and maintenance work exclusively when the compressor is stopped and depressurised. The unit should be leak-checked regularly. Leaks can be preferably localised by using a leak detector spray (if necessary, brush pipes with soapy water).

We recommend that only authorised L&W service technicians carry out service work on the bearing of the compressor (crankshaft and connecting rods).

We urgently recommend that all maintenance, repair and installation work must only be carried out by trained personnel. This is necessary because all maintenance work can not be explained exactly and detailed in this manual.

Only use authentic spare parts for service work.



Danger

Components under pressure, such as hose ends, can quickly come loose when manipulated and can cause potentially fatal injuries due to the pressure surge. Any work on system parts may only be performed in a pressure-compensated state.



Warning

The use of accessories that have not been tested can lead to death or serious injury or damage to the unit. Only use authentic spare parts for service work.



Warning

Carry out maintenance or service work when the unit is switched off and protected against unexpected restart.



Warning

Risk of burns!

Carry out maintenance or service work when the unit has cooled down.



MAINTENANCE AND SERVICE

Daily before taking unit into operation

Maintenance work	Type	Quantity	Order No.
Check oil level	-	-	000001
Check condition of all filling hoses	-	-	-
Check filter cartridge lifetime	-	-	-
Operate unit to final pressure and check function of final pressure switch or safety valve	-	-	-

At 25 operating hours

Maintenance work	Type	Quantity	Order No.
Oil change	-	1,8	000001

Every 3 months or as required

Maintenance work	Type	Quantity	Order No.
Check automatic condensate drain, open manual condensate taps	-	-	-
Check/Retorque all connections and bolts	-	-	-

A

MAINTENANCE AND SERVICE

Annually

Maintenance work	Type	Quantity	Order No.
Oil change, if less than 1000 operating hours	-	1.8	000001
Check opening pressure of final safety valve	-	-	-
Clean coolers	-	-	-
Clean all oil/water separators, if less than 500 operating hours	-	-	-
Service intake filter (depends on condition - if less than 500 operating hours)	-	-	-
Clean oil filter element, if less than 1000 operating hours	-	-	-
Check all connections for leakage	-	-	-

Every 500 operating hours

Maintenance work	Type	Quantity	Order No.
Check / Change intake filter	-	1	000170
Check pressure maintaining/non-return valve	-	-	-
Check V-belt tension and condition	-	-	-



Note

All stated quantities are parts of our 1000h, 2000h and 4000h service kits. You can find an overview on page Service Kits.

MAINTENANCE AND SERVICE

Every 1000 operating hours

Maintenance work	Type	Quantity	Order No.
Replace V-belt	LW 300 D MC	1	006810
Replace sintered metal filter element of water separators	after 2nd stage	1	002123
Replace o-rings of water separators	after 2nd stage	1	001255
Replace o-rings of the final filter housing	-	1	001769
Replace o-ring of the DIN filling connector	-	2	001237
Replace o-ring of the revolvable filling hose	-	2	001224
Replace o-ring of oil filter	-	1	006383
Replace oil filter element	-	1	008239
Replace gasket of oil filter	-	1	007948
Service Kit oil pump	-	1	002569
Oil change	-	1.8	000001



Note

All stated quantities are parts of our 1000h, 2000h and 4000h service kits. You can find an overview on page Service Kits.

MAINTENANCE AND SERVICE

Every 2000 operating hours

Maintenance work	Type	Quantity	Order No.
Replace all inlet and outlet valves incl. Gaskets	1st stage	1	007913
	2nd stage	1	007912
	3rd stage	1	000525
	Upper gasket 1st	1	007946
	Lower gasket 1st	1	007903
	Upper gasket 2nd	1	007945
	Lower gasket 2nd	1	007901
	Upper gasket 3rd	1	000541
	Lower gasket 3rd	1	000531



Note

All stated quantities are parts of our 2000h and 4000h service kits. You can find an overview on page Service Kits.

Every 4000 operating hours (Latest in 10 years)

Maintenance work	Type	Quantity	Order No.
Replace o-ring (cylinder gasket 2nd and 3rd stage)	-	2	007902
Replace needle bearings for conrod 2nd and 3rd stage	-	2	007978



Note

All stated quantities are parts of our 4000h service kits. You can find an overview on page Service Kits.

MAINTENANCE AND SERVICE

Service Kits

The service kits contain parts for maintenance according to the factory requirements.

The use of the service kits ensures that all required parts are ordered and replaced and gives assurance that all parts are included in the order. Depending on the model and interval, the service kits include parts such as O-Rings, Sinter Filter, Inlet Filter, V-Belts, Silencers, In-&Outlet Valve, Valve Seals and Compressor oil.



Fig. - Service Kits

Service Kits for LW 300 D MC

Compressor	Operating Hours	Order No.
LW 300 D MC	1000 h	009250
LW 300 D MC	2000 h	009260
LW 300 D MC	4000 h	009261



MAINTENANCE AND SERVICE

Check V-Belt Tension

The V-belts could lose tension during transportation. Please check the V-belt tension before starting the compressor.

A

Tension V-Belt

To tighten V-belt tension, loosen 4 mounting nuts of the drive motor. Use the tensioning screw to move the electric motor until the V-belt tension is sufficient. Then, tighten mounting nuts and check V-belt tension.

We recommend using a V-belt tension gauge.

Correct V-Belt Tension

Do not tension V-belts too tight. This damages bearings of compressor and motor. The V-belts should only be tensioned until there is no noise caused by slipping during start.

Settings

Motor Type	Initial Installation	Operation after running
Drive Motor LW 300 D MC	500N	400N

Compressor Lubrication

The 1st stage is lubricated by spray oil. In addition, the guide cylinders of the 2nd and 3rd stage are lubricated by a mechanical oil pump. The installed oil filter ensures clean oil supply to the mentioned guide cylinders.

A

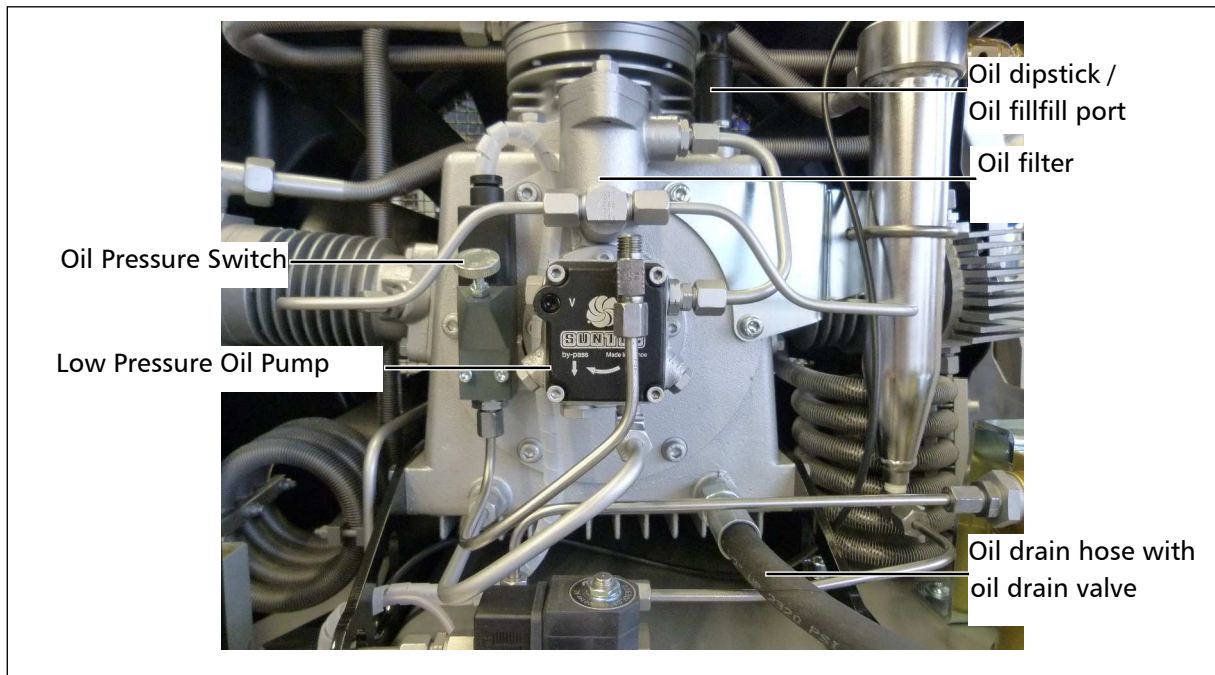

Fig. - Lubricating System

Check Oil Level



Warning

Check oil level daily. Never start the compressor with a too low oil level. Risk of accidental loss, destruction or deterioration.

Check the oil level before each operation of the unit by using the oil dipstick.

Oil level check as follows:

- Pull oil dipstick
- Wipe off oil residues
- Insert the oil dipstick back into its tube
- Pull oil dipstick again

The oil level should be between the min and max marking. A max. oil level is recommended. If there is too much oil inside, drain the oil surplus. If the oil level is too low, refill immediately new full synthetic compressor oil.

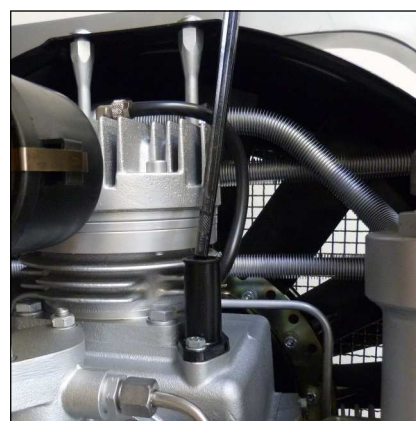

Fig. - Oil dipstick



Fig. - Marking

Oil Change

**Note**

We recommend oil change at least once a year - depending on total operating hours.

A**Oil change as follows:**

- Run compressor warm for approx. 2 min.
- Switch off and vent compressor.
- Place a suitable oil drain tray under the drain hose.
- Open carefully oil drain valve and drain oil completely.
- Close oil drain valve.
- Pull out oil dipstick
- Fill oil by using a funnel.
- Check oil level.
- Check o-ring of the oil dipstick.
- Insert oil dipstick

The oil change is now completed.

Maintenance intervals

- First oil change after 25 operating hours (total hours).
- All further changes after each 1,000 operating hours.

Oil and oil capacity

Approx. 1800 ml synthetic compressor oil is necessary for one oil change. Only use synthetic compressor oil which is recommended as suitable from L&W.

MAINTENANCE AND SERVICE

Oil Sieve Change

Oil sieve change as follows:

- Loosen cover screws (Fig.1 / 4 pcs).
- Remove the cover, the cover gasket and the oil sieve.
- Clean the oil sieve with petroleum-ether or replace the defective oil sieve.
- Replace the gaskets.
- Soak the gaskets with oil before placing (respect mounting direction).
- Be sure to position the arrow from the new oil sieve opposite to inlet and return ports of the pump (see Fig.2).
- Remount the cover with the 4 cover screws. Tightening torque: 4.5 - 8 N.

The oil sieve change is now completed.

Maintenance intervals

- We recommend cleaning or replacing the oil sieve every 1,000 working hours.
- Service Kit oil pump (002569). Consists of: 000798—Oil sieve + 000672—oil pump cover gasket

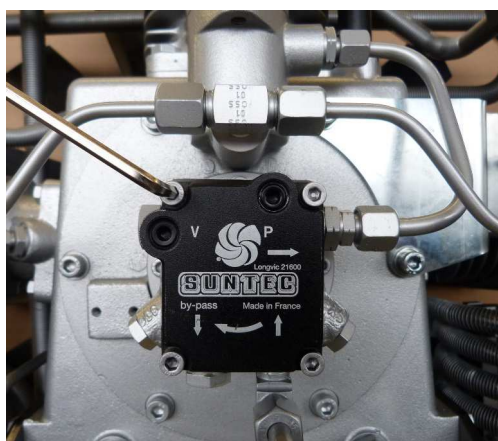

Fig. 1

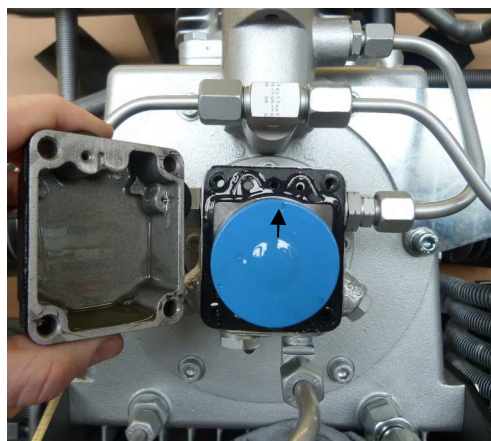

Fig. 2

Correct oil sieve mounting direction

MAINTENANCE AND SERVICE

Oil Filter Maintenance



Caution

Oil filter housing is filled with oil. Take all necessary protection measures.



Note

Clean all parts thoroughly before assembly.

Oil filter maintenance as follows:

- Loosen mounting nuts (Fig. 1) and remove oil filter cover.
- Change o-ring, previously grease new o-ring (Fig. 2).
- Remove spring and filter element (Fig. 3).
- Change gasket (Fig. 4)
- Clean oil filter housing.
- Insert filter element (Fig. 3).
- Place spring.
- Place filter cover (Fig. 2) and washers.
- Fix and tighten mounting nuts of the filter cover (Fig. 1).

The oil filter maintenance is now completed.

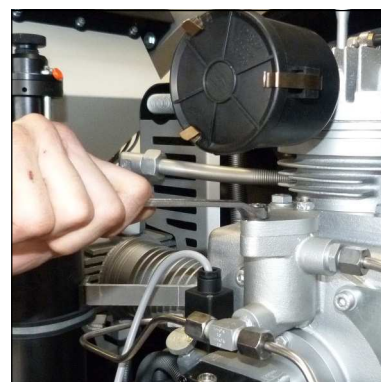

Fig. 1 - Loosen mounting nuts



Fig. 2 - Change o-ring

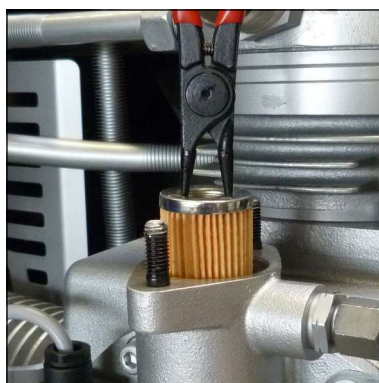

Fig. 3 - Change filter element



Fig. 4 - Change gasket

MAINTENANCE AND SERVICE

Manual Condensation Dump System



Note

The collected condensate can contain oil and has to be disposed according to regulations.

Oil- / water separators

The unit comes as standard with a manual condensation dump system. Drain condensate separators every 15 minutes.

To release the complete condensate through the black plastic hoses we recommend using a 20 l container at least.

The drain noise can be kept to a minimum by using a silencer.

Manual drain



Warning

Open valve spindle max. 1.5 turns.
The pressure in the housing can shoot out the valve spindles at high speed.

To drain manually, open the condensate drain valves of the 2nd oil / water separator and the condensate drain valve of the final filter housing (Fig. 2).

Open valve spindle max. 1.5 turns anti-clockwise. The condensate will be drained.

Then close valve spindle clockwise.

Maintenance intervals

We recommend to clean oil and water separators every 500 operating hours or at least once a year, to check for corrosion damage and to replace o-rings if necessary.

All oil / water separators have an integrated sinter filter which has to be replaced every 1,000 operating hours.

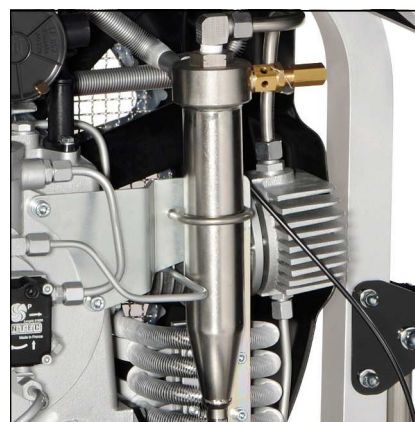

Fig. 1 Oil / water separators after 2nd stage with automatic condensate drain system

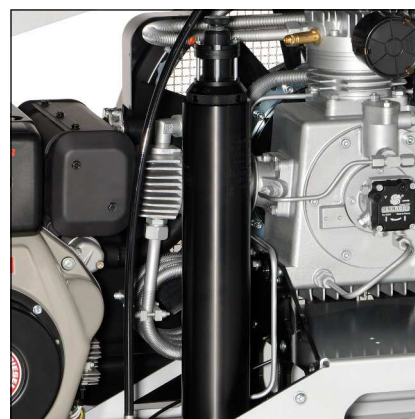

Fig. 2 - Final filter housing



Fig. 3 - Condensate drain valve

A

Oil / Water Separator 2nd Stage - Maintenance



Note

Clean all parts thoroughly before assembly.

Maintain oil / water separators 1st and 2nd stage as follows:

- Loosen pipe connections (Fig. 1)
- Loosen screw connection at the water separator (sinter filter holder)
- Remove sinter filter holder (Fig. 2).
- Change sinter filter (Fig. 3), screw-in new sinter filter by using a suitable screwdriver.
- Change o-ring, previously grease new o-ring (Fig. 4)
- Place sinter filter holder into the water separator and tighten
- Connect pipe connections and tighten.

The oil / water separator maintenance is now completed.

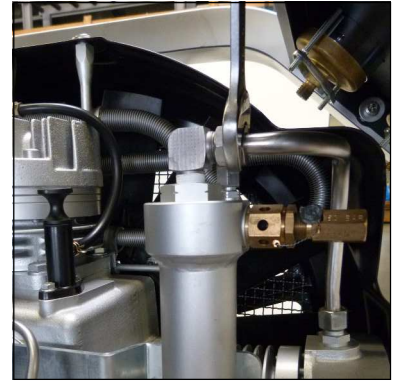

Fig. 1 - Loosen pipe connections



Fig. 2 - Remove sinter filter holder



Fig. 3 - Change sinter filter



Fig. 4 - Change o-ring

MAINTENANCE AND SERVICE

Filter Housing

The black mole carbon filter housing is installed on the right hand side of the motor.

Inside the filter housing a jet blows air on to the housing wall. Condensation water and oil are led by centrifugal force to the bottom of the housing. Air flows through the mole carbon filter cartridge, which purifies the air from residual moisture and odours.



Fig. - Filter housing



Caution

Do not run the compressor with empty unfilled cartridges.
Only use genuine L&W cartridges.

Filter cartridge

P/N	Model	Filtering	Filter Housing
002309	LW 300 D MC	DIN EN 12021 (Breathing Air) incl. CO/CO ₂	0.37 ltr
001459	LW 300 D MC (Option)	DIN EN 12021 (Breathing Air) incl. CO/CO ₂	0,54 ltr

The high-pressure compressor is equipped with an integrated breathing air purification system. Air is compressed up to 350 bar, dried and odour- and tasteless purified. Oil residues are bounded.

The breathing air filter cartridge consists of a molecular sieve and activated-carbon filter.

All breathing air filter cartridges are factory vacuum sealed.

We recommend unpacking the filter cartridges just before installation. Filter cartridges which are exposed too long could be saturated with moisture and become unusable.

Maintenance intervals

Filter cartridges should be changed at the following intervals, at +20°C or more often, depending on humidity and ambient temperature:

Standard life time at 20°C:

- 4,5 hours for LW 320 D MC (39,1 hours for LW 300 D MC / Option filter housing)

MAINTENANCE AND SERVICE



Caution

Do not run the compressor with empty unfilled cartridges.
Only use original L&W genuine.

A

Filter Cartridge Change LW 300 D MC

Filter cartridge change as follows:

- Stop the compressor and open carefully the drain valves. Please wait till the filter housing is completely vented; this procedure takes approx. 1 - 2 minutes
- When no air discharges from the condensate release hoses, the pressure vessels are depressurized.
- Remove the end filter cover (Fig. 1). Remove the filter cover by using the filter tool. The housing can not be opened when it is still under pressure.
- After opening the housing, pull out the filter cartridge by the catch (Fig. 2).
- Open the packaging of the new filter cartridge and place it into the filter housing (press slightly).
- Screw the filter housing cover in by using the filter tool and turn it back 1/4 turn. This avoids tightening of the cover due to vibration.

The filter cartridge change is now completed.



Fig. 1 - Loosen filter housing cover by using the filter tool



Fig. 2 - Pull out the filter cartridge by the catch and insert a new cartridge



Note

Ensure that the old filter cartridge is disposed correctly at an approved waste point.



Caution

Do not run the compressor with empty unfilled cartridges.
Only use genuine L&W cartridges.

A

Filter Cartridge Change LW 300 D MC (Option)

Change filter cartridge as follows:

- Stop the compressor and carefully open the drain valves. Wait till the filter housing is completely vented; this procedure takes approx. 1 - 2 minutes
- When no air discharges from the condensate release hoses, the pressure vessels are depressurized.
- Remove the end filter topcap (Fig. 1). Remove the filter cover by using the filter tool. The housing can not be opened if still under pressure.



Fig. 1 - Loosen filter housing topcap by using the filter tool

- After opening the housing, pull out the filter cartridge by using the filter tool (Fig. 2).
- Remove adapter from used cartridge.
- Open the vacuum sealed packet of the new filter cartridge and carefully place it into the filter housing (press slightly).
- Put on filter adapter (Fig. 3) on new cartridge. Use spanner to make sure adapter is sealing to cartridge bottom. Insert filter cartridge (incl. installed filler adapter).
- Fully turn in filter housing topcap in by using the filter tool and turn it back 1/4 turn. This avoids tightening of the topcap due to vibration.
- **The filter cartridge change is now completed.**



Fig. 2 - Pull out the filter cartridge by the catch and insert a new cartridge



Fig. 3 - Filter adapter



Fig. 4 - Installed filler adapter



Note

Ensure that the old filter cartridge is disposed correctly at an approved waste point.

Filter Housing - Maintenance

**Note**

Clean all parts thoroughly before assembly.

Filter housing maintenance as follows:

- Unscrew filter housing cover by using the filter tool (Fig. 1).
- Change o-ring, previously grease new o-ring (Fig. 2)
- Screw the filter housing cover in by using the filter tool (Fig. 1).

The filter housing maintenance is now completed.



Fig. 1 - Remove/screw in filter cover



Fig. 2 - Change o-ring

Inlet Filters



Note

Dirty filters make intaking air difficult and reduce delivery capacity. Risk of compressor overheating.

A micro filter cartridge is used as an air inlet filter. Check air inlet filter regularly or replace it. Defective air inlet filters should be immediately replaced with a corresponding filter.

Maintenance intervals

We recommend that the filter cartridge should be replaced every 500 working hours (depending on pollution grade).

Inlet filter cartridge change

Inlet filter cartridge change as follows:

- Loosen cover by pushing the three clips apart.
- Remove inlet filter cartridge and replace it by a new one.
- Refit cover and snap the three clips until a loud 'click' can be heard.

The inlet filter cartridge change is now completed.

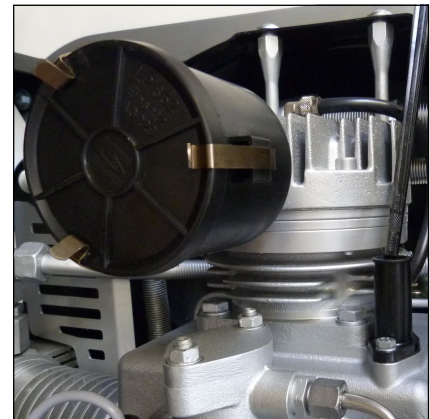

Fig. - Air filters

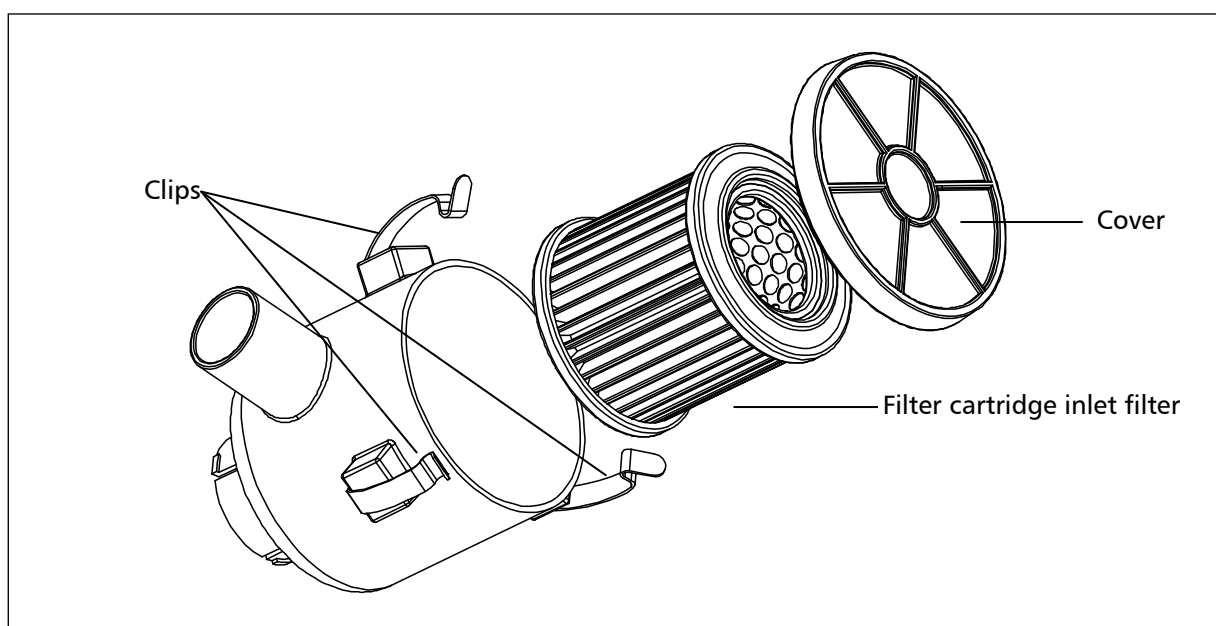

Fig. - Filter cartridge inlet filter

MAINTENANCE AND SERVICE

Cylinder Heads and Valves

Inlet and outlet valves of the specific compressor stages are located between valve head and cylinder. Outlet valves open while piston downstroke, inlet valves open while upstroke or compression stroke.

Valves are subject to normal wear and tear and have to be replaced at certain intervals (depending on specific operating conditions). Dismount valve heads to change valves. The three valves are combined inlet and outlet valves. The first stage is a plate valve. The stages two and three are made of a spring operated piston which acts inside a bronze cylinder.



Fig. - Inlet and outlet valve incl. gaskets of the 3rd stage

Maintenance intervals

All valves should be replaced after 2000 working hours due to normal wear and tear. To replace valves the cylinder heads have to be removed. There are no special tools required to replace these valves.

Available special tools

Special tools are not necessary for dismounting inlet and outlet valves but make work easier.

Order number: 006847



Fig. - Special tool

MAINTENANCE AND SERVICE

Fan Protection Cover Dismantling

Dismantle the fan protection cover as follows:

- Remove top mounting screws (Fig. 1).
- Remove fan protection cover.

The fan protection cover dismantling is now completed.

Mounting the Fan Protection Cover

Mount the fan protection cover as follows:

- Place the fan protection cover.
- Note the fixing stud on the frame (Fig. 2).
- Use the hole in the protection cover with the fixing stud
- Tighten top mounting screws (Fig. 1).

The fan protection cover mounting is now completed.



Fig. 1 - Remove top mounting screws

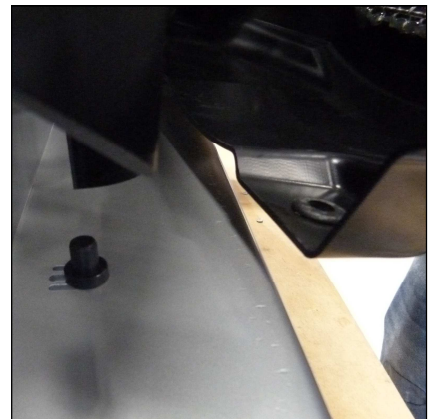

Fig. 2 - Fixing stud

A

Replace Inlet and Outlet Valve 1st Stage

Inlet and outlet valves change as follows:

- Remove crankcase ventilation hose (Fig. 1)
- Loosen pipe connections of 1st cooling pipe (Fig. 2).
- Loosen clamp of cooling pipe (Fig. 3).
- Remove 1st cooling pipe.
- Loosen pipe connections of 2nd cooling pipe (Fig. 4).
- Remove cooling pipe bracket (Fig. 5).
- Remove complete 2nd cooling pipe.
- Remove special hexagon bolt (Fig. 6).
- Remove cylinder head mounting screws.
- Remove complete valve head 1st stage (Fig. 7).

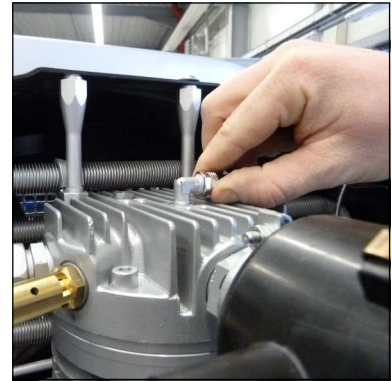

Fig. 1 - Crankcase ventilation hose



Fig. 2 - Pipe connection

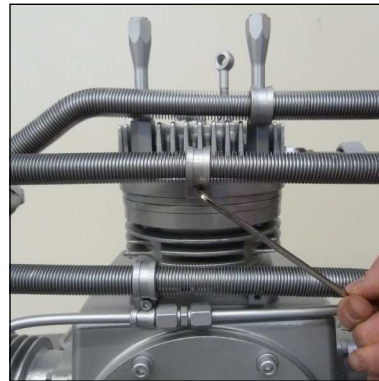

Fig. 3- clamp of cooling pipe



Fig. 4 - Loosen pipe connections



Fig. 5 - Remove cooling pipe bracket



Fig. 6 - Remove special hexagon bolt



Fig. 7 - Remove valve head

Continued on the **following page**

Replace Inlet and Outlet Valve 1st Stage

(continued from previous page)

- Change lower valve gasket (o-ring) (Fig.1).
- Remove in and outlet valve and upper valve gasket.
- Place new valve gasket on new in and outlet valve
CAUTION: Ensure correct mounting position of the upper valve gasket (Fig. 2).
- Place valve head on cylinder
CAUTION: Ensure correct mounting position of the valve head (Fig. 3).
- Place mounting screws and special hexagon bolts and tighten crosswise (tightening torque 30 Nm) (Fig 4).
- Place complete 2nd cooling pipe.
- Connect cooling pipe bracket and tighten.
- Connect pipe connections of 2nd cooling pipe and tighten.
- Place 1st cooling pipe.
- Connect clamp of cooling pipe and tighten.
- Connect pipe connections of 1st cooling pipe and tighten (Fig. 5).
- Fix crankcase ventilation hose.



Fig. 1 - Change lower gasket (o-ring)



Fig. 2 - Correct mounting position of upper valve gasket



Fig. 3 - Place valve head to cylinder

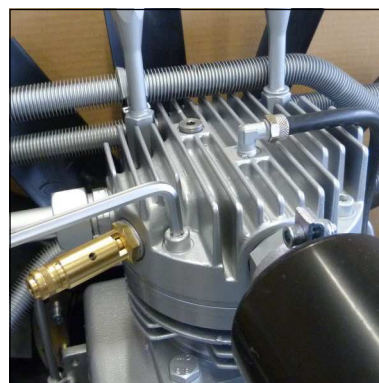

Fig. 4 - Tighten mounting screws

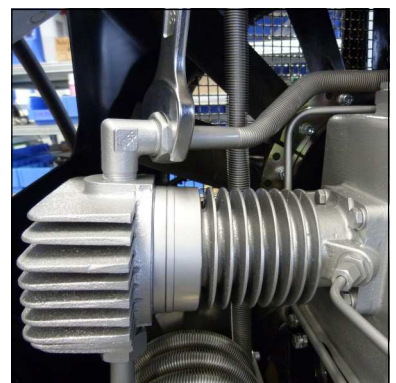

Fig. 5 - Tighten pipe connections

Replace Inlet and Outlet Valve 2nd Stage

Inlet and outlet valves change as follows:

- Loosen pipe connections of 1st cooling pipe (Fig. 1).
- Loosen clamp of cooling pipe (Fig. 2).
- Remove 1st cooling pipe.
- Loosen pipe connections of 2nd cooling pipe (Fig. 3).
- Remove cooling pipe bracket (Fig. 4).
- Remove complete 2nd cooling pipe.
- Remove special hexagon bolt (Fig. 5).
- Remove cylinder head mounting screws.
- Remove complete valve head 1st stage (Fig. 6).

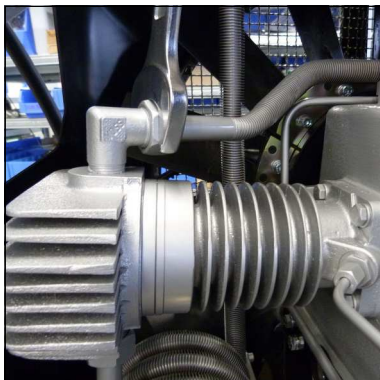

Fig. 1 - Pipe connection

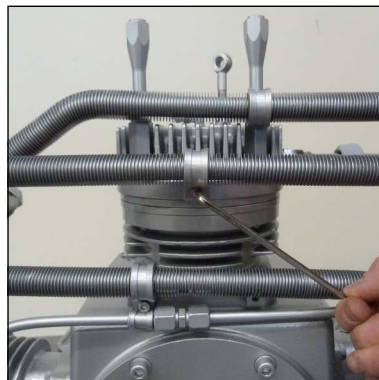

Fig. 2 - clamp of cooling pipe



Fig. 3 - Loosen pipe connections



Fig. 4 - Remove cooling pipe bracket



Fig. 5 - Remove cylinder bolts

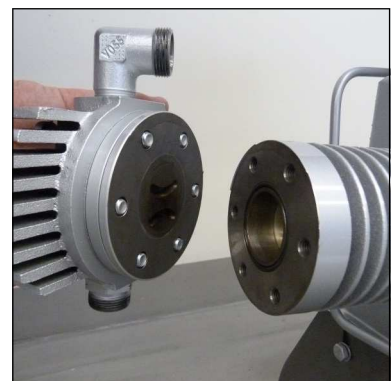

Fig. 6 - Remove valve head

Continued on the following page

MAINTENANCE AND SERVICE

Replace Inlet and Outlet Valve 2nd Stage

(continued from previous page)

- Change lower valve gasket (o-ring) (Fig.1).
- Remove in and outlet valve and upper valve gasket.
- Place new valve gasket on new in and outlet valve
CAUTION: Ensure correct mounting position of the upper valve gasket (Fig. 2).
- Place valve head on cylinder
CAUTION: Ensure correct mounting position of the valve head (Fig. 3).
- Place cylinder screws and tighten crosswise (tightening torque 30 Nm) (Fig 4).
- Place complete 2nd cooling pipe.
- Connect cooling pipe bracket and tighten.
- Connect pipe connections of 2nd cooling pipe and tighten.
- Place 1st cooling pipe.
- Connect clamp of cooling pipe and tighten.
- Connect pipe connections of 1st cooling pipe and tighten (Fig. 5).

The inlet and outlet valve change is now completed.

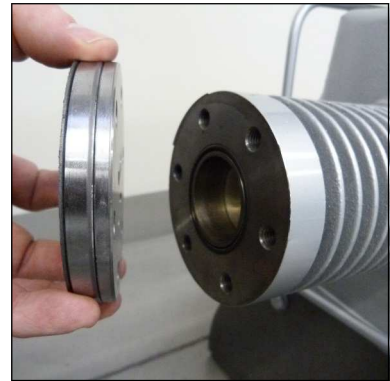

Fig. 1 - Change lower gasket (o-ring)



Fig. 2 - Correct mounting position of upper valve gasket



Fig. 3 - Place valve head to cylinder

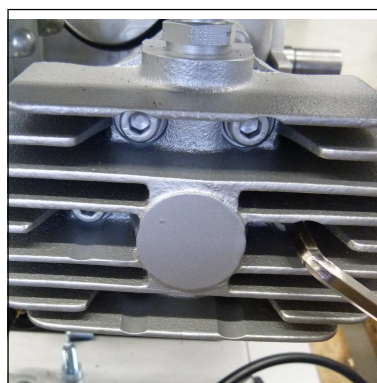

Fig. 4 - Tighten mounting screws

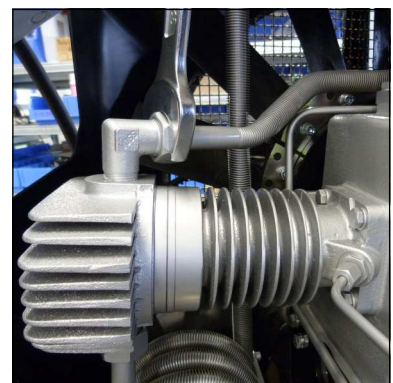

Fig. 5 - Tighten pipe connections

Replace Inlet and Outlet Valve 3rd Stage



Note

The connections on the valve head can be different.

Inlet and outlet valves change as follows:

- Loosen pipe connections (Fig. 1).
- Loosen valve head screws (Fig. 2).
- Remove lower valve gasket (Fig. 3).
- Dismount inlet and outlet valve (Fig. 4).
Observe that the upper valve gasket is also pulled out. It can still stick inside the cylinder head.
- Check valve head if defective (check centre pin)
- Mount valve gasket on inlet and outlet valve
CAUTION: Ensure correct mounting position of the upper valve gasket (Fig. 5).
- Insert new inlet and outlet valve into valve head
CAUTION: Observe correct position between valve centre hole and valve head centre pin.
- Place lower valve gasket
- Place valve head with the new inlet and outlet valve. Tighten valve head screws crosswise (tightening torque 35 Nm).
- Connect pipe connections and tighten.

The inlet and outlet valve change is now completed.

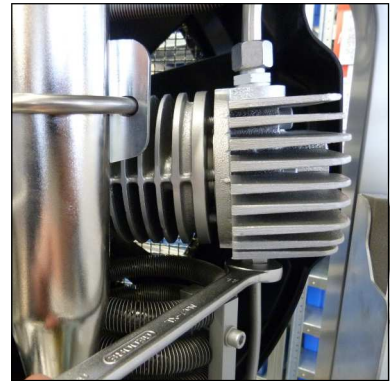

Fig. 1 - Loosen pipe connections

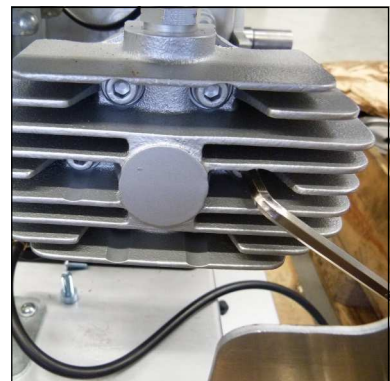

Fig. 2 - Loosen valve head screws

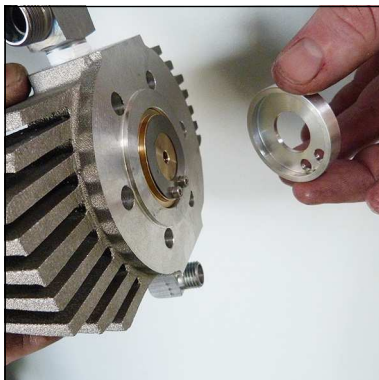

Fig. 3 - Remove lower valve gasket



Fig. 4 - Remove inlet and outlet valve



Fig. 5 - Ensure correct mounting position of the upper valve gasket

MAINTENANCE AND SERVICE

Safety Valves

Every pressure stage is equipped with a separate over pressure safety valve. Safety Valves avoid a non permissible high pressure at the specific pressure stages and limit maximum operation pressure of the compressor.

Safety valves are adjusted to:

- 1st Stage: 8 bar
- 2nd Stage: 70 bar
- 3rd Stage: max. final pressure

The adjusted blow-off pressure [bar] of the safety valves is indicated on their housings.

All safety valves are factory sealed with special L&W safety seals to avoid manipulation of the limit value settings.

Safety valves with removed seals have to be immediately checked for the prescribed settings and replaced if necessary.

The safety valve of the final stage is furthermore equipped with a knurled screw to be activated once.

Turning the knurled screw clockwise could vent the valve completely and therefore the final filter housing.

During normal operation conditions, the knurled screw has to be turned anti-clockwise up to the upper stop. An integrated circlip avoids complete unscrewing.

If a safety valve blows off, it indicates problems with either inlet or outlet valve of the following stage.



Note

Replace defective safety valves immediately!

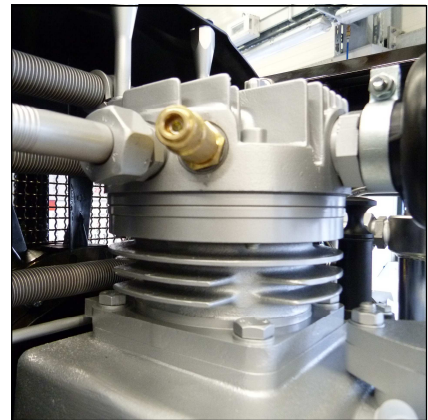

Fig. - Safety valve 1st stage

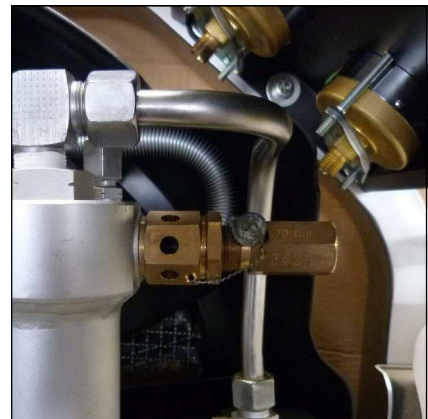

Fig. - Safety valve 2nd stage



Fig. - Safety valve 3rd stage

A

Pressure Maintaining / Non Return Valve

The pressure maintaining / non return valve combination is placed in the flow direction after the final filter housing.

Pressure Maintaining Valve

The pressure maintaining valve drains a large part of the water content of the compressed air mechanically by ensuring the minimum outlet pressure. This guarantees optimal drying and purification of the breathing air.

After starting the compressor, the pressure inside the final filter housing constantly increases. The pressure maintaining valve prevents the compressed air from blowing off (final pressure gauge = 0 bar).

When the adjusted opening pressure is reached (150 and 180 bar), the purified compressed air flows via pressure maintaining and non return valve to the filling valve.

The value of the opening pressure of the pressure maintaining valve can be read at the final pressure gauge. When opening pressure is reached, the pressure gauge value increases within a few seconds.

Adjust pressure maintaining valve see next page.

Non Return Valve

The non return valve which is placed after the pressure maintaining valve, prevents the purified breathing air from flowing back into the filter housing / condensate drain valves.

After compressor stop, the indicated filling pressure remains constant, if the non return valve is working correctly.



Fig. - Drain valve and pressure maintaining / non return valve

A

Adjust Pressure Maintaining Valve

- Vent filling valve and close afterwards (filling pressure gauge 0 bar)
- Start the compressor
- Observe filling pressure gauge
- When the opening pressure of the pressure maintaining valve is reached, the indicated filling pressure increases within some seconds from 0 bar up to the adjusted opening pressure.

If the opening pressure does not reach a value between 150 and 180 bar, adjust the pressure maintaining valve as follows:

Increase opening pressure:

- Vent filling valve (filling pressure 0 bar)
- Loosen clamp screw on the side
- Turn adjusting screw clockwise by using a suitable slotted screwdriver
- Start compressor and check opening pressure, adjust if necessary
- Tighten clamp screw on the side
- Check opening pressure again

Reduce opening pressure:

- Vent filling valve (filling pressure 0 bar)
- Loosen clamp screw on the side
- Turn adjusting screw anti-clockwise by using a suitable slotted screwdriver
- Start compressor and check opening pressure, adjust if necessary
- Tighten clamp screw on the side
- Check opening pressure again



Note

If the adjusted opening pressure of the pressure maintaining valve is higher than the final pressure of the compressor, the final pressure safety valve blows off before pressure maintaining valve opens (final pressure = 0 bar). When valve settings are not clear (e.g. after disassembly / repair), start the adjustment with a low basic setting (turn adjusting bolt 3 full turns in).

MAINTENANCE AND SERVICE

O-Rings - Filling Valve and Filling Hose

Check o-rings from filling valve and filling hose regularly and change if necessary.



Note

Clean all parts thoroughly before assembly.

O-Ring at the Filling Valve

- Change o-ring, previously grease new o-ring (Fig. 1)

O-Ring at the Filling Hose

- Remove filling hose from the filling valve (Fig. 2)
- Change o-ring, previously grease new o-ring
- Connect filling hose to the filling valve and tighten



Fig. 1 - O-ring at the filling valve



Fig. 2 - O-ring at the filling hose



MAINTENANCE AND SERVICE

A

Test of Pressure Equipment

According to the Pressure Equipment Directive (PED 97/23/EC) and TÜV Darmstadt (German supervising authorities). State: 10th of December, 2005

Subject: pressure equipment with a product permissible operating pressure [bar] x content volume [litres] from 200 up to 1000.

Example: Filter housing 0.57 l

Maximum operating pressure: 350 bar

Content volume: 0.57 litres

$350 \text{ bar} \times 0.57 \text{ litres} = 199.5$

199.5 is smaller than the minimum of 200 -> therefore no test by a licensed expert is required.

Example: Filter housing 0.54 l

Maximum operating pressure: 350 bar

Content volume: 0.54 litres

$350 \text{ bar} \times 0.54 \text{ litres} = 189$

189 is smaller than the minimum of 200 -> therefore no test by a licensed expert is required.

1. Examination after 5 years by a qualified person or authorized organisations.

Visual inspection, inside and outside.

2. Examination after 10 years by a qualified person or authorized organisations.

Visual inspection, inside and outside.

In addition, a water pressure test is carried out at 1.5 times of the permissible vessel operating pressure.

The test methods described in point 1 and 2 must be repeated periodically - as described above.

Max. numbers of load cycles for operation with max. allowable pressure variation		
Final pressure [bar]	Load cycles	Operating hours [h]
225	43750	10930
330	4400	1100



A

MAINTENANCE RECORDS



MAINTENANCE RECORDS

Introduction form for the Operator

A

No.	Surname, Name	Date	Place	Signature	Instructor

By adding themselves to this list, the person that signs it confirms having been given a yearly introduction/instruction about the function and operation of the compressor unit. Furthermore, they have been informed about the relevant safety rules and regulations (TRG, DGRL, BetrSichV, GSG, GSGV).



MAINTENANCE RECORDS

Top up oil, oil change

Date	Operating hours	Oil quantity [l]	Name

A



MAINTENANCE RECORDS

Maintenance work

Description	Date, signature

A



STORAGE

Conservation / Storage of the Compressor

If the compressor is not to be used for an extended period of time, we recommend the following conservation work to be carried out before the storage:

- Run the compressor at 200 bar for approx. ten minutes
- Drain warm oil and replace by new oil.
- Open filling valves and run the compressor for a few minutes.
- Stop the compressor and open the drain valves.
- Close filling valves.
- Open the final filter housing and lubricate the O-Ring with a food grade grease or silicone grease.
- Store the compressor in a cool dry place free from dust and contamination. A cover is recommended as long as condensation can be avoided.

De-Conservation, Commissioning

After the compressor has been stored, the following steps are to be taken:

- Replace the final purification filter.
- Check oil level, replace oil if necessary. Fuel Driven Units only: Fill up fuel tank to top level to avoid corrosion.
- Inspect the condition of the v-belts, replace if necessary
- Inspect the filling hoses visually for signs of deterioration, replace as necessary.
- Fix filling valves by e.g. cable strips to avoid whipping around wildly. Open filling valves.
- Open the filling valves and run the compressor for approx 10 minutes with the filling valves open.
- Close the filing valves and allow the compressor to build up to working pressure.
- Check the correct safety valve setting and/or pressure switch setting (option).
- Check all connections and pipe work for leaks, retighten if necessary.

Once the above steps are completed to satisfaction, the unit is ready to use.

STORAGE

Transportation Instructions

- Parts which need to be dismantled for transport purposes must be carefully replaced and secured before taking into operation.
- The transport may only be carried out by trained personnel.
- For transportation, only use lifting devices and equipment with sufficient lifting power.
- Do not stand or work under suspended loads.
- Also separate from minor relocation machinery / system of any external energy supply. Before recommissioning, reconnect the machine to the mains according to regulations.
- When recommissioning, proceed according to the operating instructions..

Disposal

The product must be disposed in accordance with national waste disposal regulations and by an appropriate waste disposal company.

Electric and Electronic Components

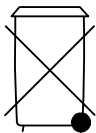

EU-wide regulations for the disposal of electric and electronic appliances which have been defined in the EU Directive 2002/96/EC and in national laws are effective from August 2005 and apply to this device.

Common household appliances can be disposed by using special collecting and recycling facilities. However, as this device has not been registered for household usage, it must not be disposed of through these means.

The device can be returned to L&W. Please do not hesitate to contact us if you have any further questions on this issue.

NEW!

LW 300 D MC



The new MC Series from L&W has been created for dive centers, ships, boats and places with limited space. These are suitable for continuous operation and guarantee low maintenance costs due to long service intervals. Comes ready to start. A super lightweight aluminum frame enables mobile applications, combined with very high filling capacity.

B



Lenhardt & Wagner GmbH

An der Tuchbleiche 39
68623 Hüttenfeld / Germany

Phone: +49 (0)62 56 - 8 58 80 -0

Fax: +49 (0)62 56 - 8 58 80 -14

eMail: service@lw-compressors.com

Internet: www.lw-compressors.com

NEW!

LW 300 D MC



Specifications

- » Diesel Engine
- » Painted lightweight aluminium frame in RAL 7001
- » Hour counter
- » Manual condensate drain
- » 1 x Filling hose c/w filling valve
- » Pressure maintaining and non return valve
- » All pistons c/w steel piston rings
- » Low pressure oil pump
- » Oil filter with bypass
- » Oil- / Water separators after 2nd and 3rd stage
- » Safety valves after each stage
- » 3 x concentric suction/pressure valves
- » Filling pressure to your choice (200 or 300 bar)
- » Connections to your choice (DIN 200 bar or 300 bar, CGA 200 bar or 300 bar and INT)
- » Breathing air purification in accordance to EN 12021
- » 1.7 l filter system (Filter capacity 750 m³ at +20°C)



Rear view

B

Options

- » Automatic condensate drain incl. collecting tank
- » Automatic stop at final pressure
- » Additional filling hoses c/w filling valves
- » 200 and 300 bar parallel filling pressures
- » Oil- and interstage pressure gauges
- » Oil pressure monitoring c/w auto shut down
- » Additional high pressure outlet
- » Wheel set
- » Air Cooler Connection Kit
- » Switch Over Device 200 / 300bar
- » Puracon filter monitoring

Technical Data

LW 300 D MC	
Type:	Air cooled piston compressor
Capacity [litre/min] / [Nm ³ /h] / [cfm]:	300 / 18.0 / 10.6
Max. Pressure [bar]:	350
RPM [1/min]:	1300
No of cylinders / No of stages:	3 / 3
Prime mover type:	Yanmar - Diesel Engine
Drive power [kW] / [HP]:	7.4 / 10.0
Cooling air requirement [Nm ³ /h]:	2220
Lubrication type:	Oil pump + Splash oil
Oil capacity [litre]:	approx. 1.8
Oil pressure [bar]:	2.5 (± 0.5)
Operating temperature [°C]:	+5°C to +45°C
Filter capacity [m ³ at +20°C] ¹⁾ :	700 (at +20°C)
Dimensions L x W x H [mm]:	1410 x 510 x 826
Weight [kg]:	195
Noise level [dB]:	95.9 (measured at 1 m)

¹⁾ In accordance with EN 12021

Lenhardt & Wagner GmbH

An der Tuchbleiche 39
68623 Hüttenfeld / Germany

Phone: +49 (0)62 56 - 8 58 80 -0
Fax: +49 (0)62 56 - 8 58 80 -14

eMail: service@lw-compressors.com
Internet: www.lw-compressors.com



**ERSATZTEILLISTEN / SPARE PARTS LISTS
DETAILANSICHTEN / DETAILED VIEWS**

C



Inhaltsverzeichnis - Table of Contents

Gesamtansicht Kompressor - Overall View Compressor	3
Gesamtansicht Verdichtereinheit - Overall View Compressor Assembly.....	4
Grundgestell - Main Frame.....	5
Lüfterabdeckung - Fan Guard	9
Quertraverse Füllventil - Transverse Traverse Filling Valve.....	12
Hochdruckabgang - High Pressure Outlet	14
Motor - Engine	18
Kompressorblock - Compressor Block.....	20
Kurbeltrieb - Crank Drive.....	24
Kolben 1. Stufe - Piston 1st Stage	26
Kompressionskolben 2. Stufe - Compression Piston 2nd Stage.....	28
Kompressionskolben 3. Stufe - Compression Piston 3rd Stage.....	30
Saug & Druckventil 1. & 2. Stufe - In & Outlet Valve 1st & 2nd Stage	32
Saug & Druckventil 3. Stufe - In & Outlet Valve 3rd Stage.....	34
Kühler 1. Stufe - Cooler 1st Stage	36
Kühler 2. Stufe - Cooler 2nd Stage.....	38
Kühler 3. Stufe - Cooler 3rd Stage.....	40
Lüfterrad - Flywheel Assembly	42
Wasserabscheider - Water Separator	44
Ansaugfilter - Intake Filter.....	46
Ölablassschlauch - Oil Drainage Tube	48
Ölpumpe - Oil Pump.....	50
Endfiltergehäuse LW 300 D MC Option - Final Filter Tower LW 300 D MC Option.....	52
Sicherheitsventil - Safety Valve	55

DETAILANSICHT / DETAILED VIEW

Gesamtansicht Kompressor / Overall View Compressor

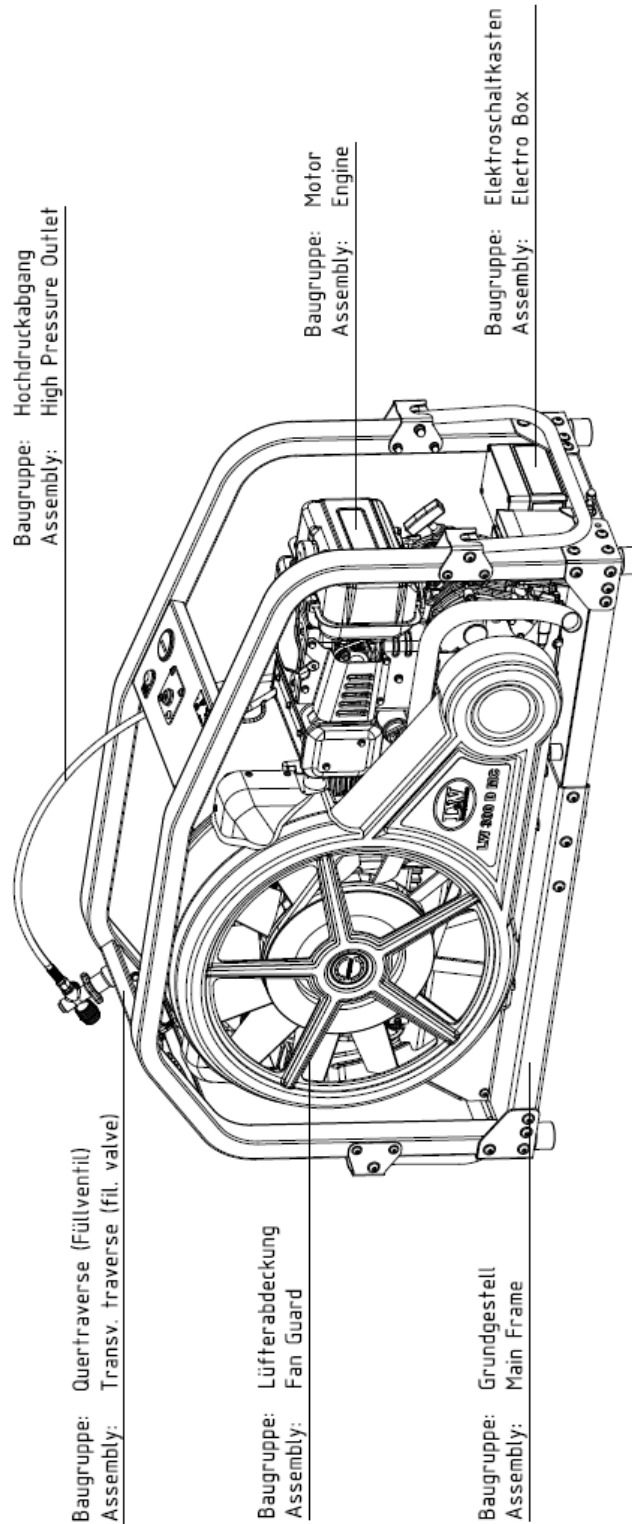

C

DETAILANSICHT / DETAILED VIEW

Gesamtansicht Verdichtereinheit / Overall View Compressor Assembly

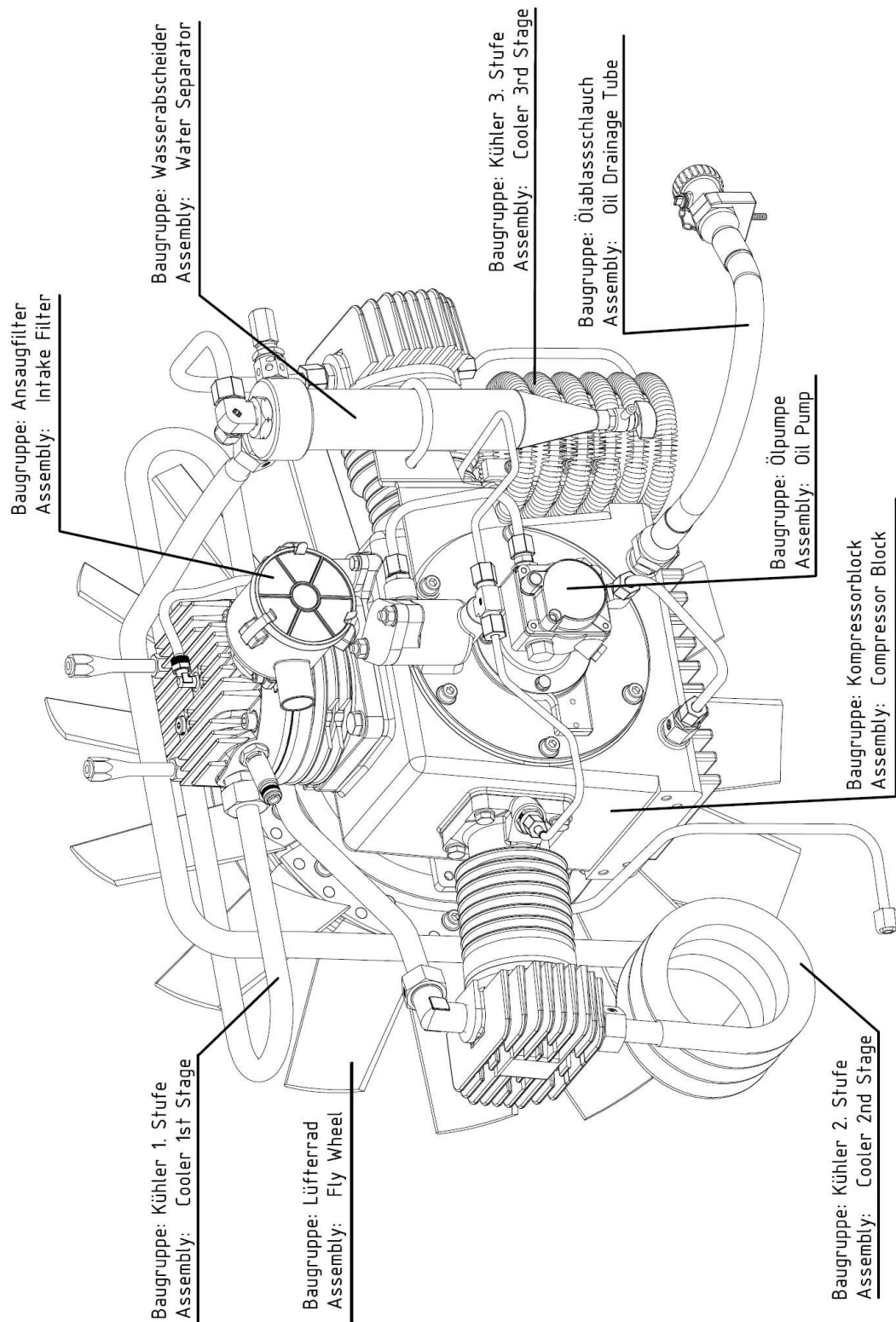



ERSATZTEILLISTE / SPARE PART LIST

Baugruppe: Grundgestell / Assembly: Main Frame

Best.-Nr. / Order No.	Benennung	Description
000967	Zylinderschraube	Allen Bolt
001040	Zylinderschraube	Allen Screw
001082	6-kant Schraube	Hexagon Screw
001159	Stopfmutter	Lock Nut M8
001160	Hutmutter	Domed Nut M8
001164	Stopfmutter	Lock Nut M10
001181	U-Scheibe A8	Washer A8
001182	U-Scheibe A8	Washer A8
001186	U-Scheibe A10	Washer A10
002513	Hutmutter M10	Cap nut M10
007729	Mutter halbhoch	Half Nut M10 DIN 439
008000	Gewindeklotz Rohrbügelbefestigung	Threaded Block (Pipe fixing)
008059	Tragegriff - Rahmen LW 250	Carrying Handle
008286	Stopfen für Rundrohr Ø25mm	Plugs for round tube Ø25mm
008346	Distanzhülse Tragegriff	Spacer
008374	Grundkonsole	Main Console
008378	Eckprofil 1	Corner Profile 1
008379	Eckprofil 2	Corner Profile 2
008380	Eckprofil 3	Corner Profile 3
008381	Eckprofil 4	Corner Profile 4
008385	Blockhaltewinkel	Block Braket
008386	Blockhaltewinkel links	Block Braket left side
008387	Griff-Halteblech	Handle Holder (Switch box)
008389	Quertraverse Füllventil	Transv. traverse (fil. valve)
008415	Linsenflanschschraube M10x75	lens head screw
008416	Linsenflanschschraube M8x75	lens head screw
008417	Linsenflanschschraube M10x25	lens head screw
008418	Linsenflanschschraube M10x20	lens head screw
008419	Linsenflanschschraube M8x25	lens head screw



ERSATZTEILLISTE / SPARE PART LIST

Baugruppe: Grundgestell / Assembly: Main Frame

Best.-Nr. / Order No.	Benennung	Description
008942	Rohrbügel B-Version, links	Frame Bar aluminum, left side
008943	Rohrbügel B-Version, rechts	Frame Bar aluminum, right side
009231	Motorkonsole D-Version	Motor Console
009232	Standfuß, Gummipuffer	Rubber Stand
009234	Quertraverse	Transv. traverse (motor side)

C

DETAILANSICHT / DETAILED VIEW

Baugruppe: Grundgestell / Assembly: Main Frame

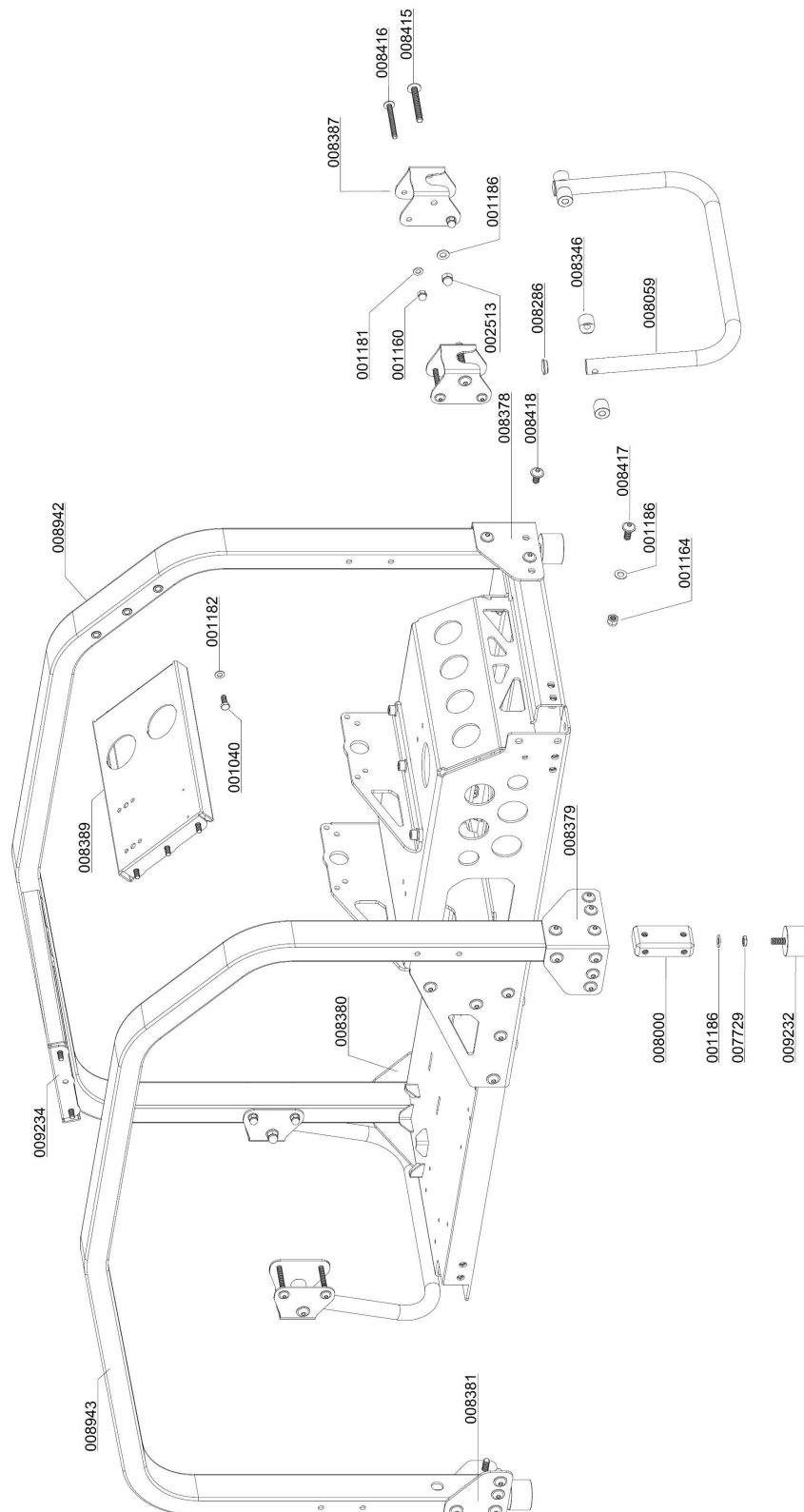

C

DETAILANSICHT / DETAILED VIEW

Baugruppe: Grundgestell / Assembly: Main Frame

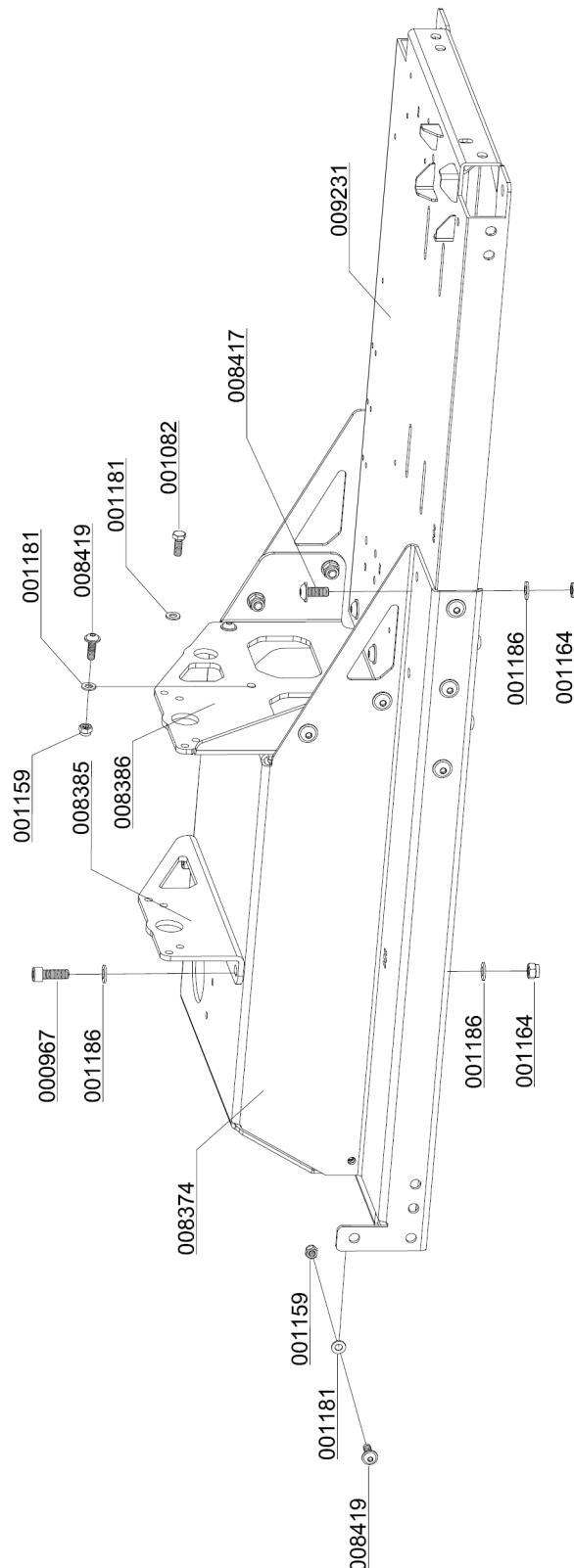

C



ERSATZTEILLISTE / SPARE PART LIST

Baugruppe: Lüfterabdeckung / Assembly: Fan Guard

Best.-Nr. / Order No.	Benennung	Description
001176	U-Scheibe A5	Washer A5
001859	Befestigungsschraube Antriebsabdeckung	Fixing Bolt V-Belt Cover
006552	Aufkleber "L&W Logo + Compressors" weiß	Sticker "L&W"
008015	Aufkleber Rotation	Sticker Rotation
008396	Gummitülle, Aufsteckgum. Ventilatorsch.	Rubber Grommet
008397	Aufsteckstutzen Lüfterabdeckung	Plug-on Fan Cover
008419	Linsenflanschschraube M8x25	lens head screw
008421	Linsenflanschschraube M5x10	lens head screw
008530	Eingriffschutz 2 Lüfterabdeckung	Safety Guard 2
008884	Aufsteckstutzen Lüfterabdeckung	Plug-on Fan Cover
009235	Aufkleber "LW 300 D MC"	Sticker "LW 300 D MC"
009236	Lüfterabdeckung mit Schutzgitter	Fan Guard complete

C

DETAILANSICHT / DETAILED VIEW

Baugruppe: Lüfterabdeckung / Assembly: Fan Guard

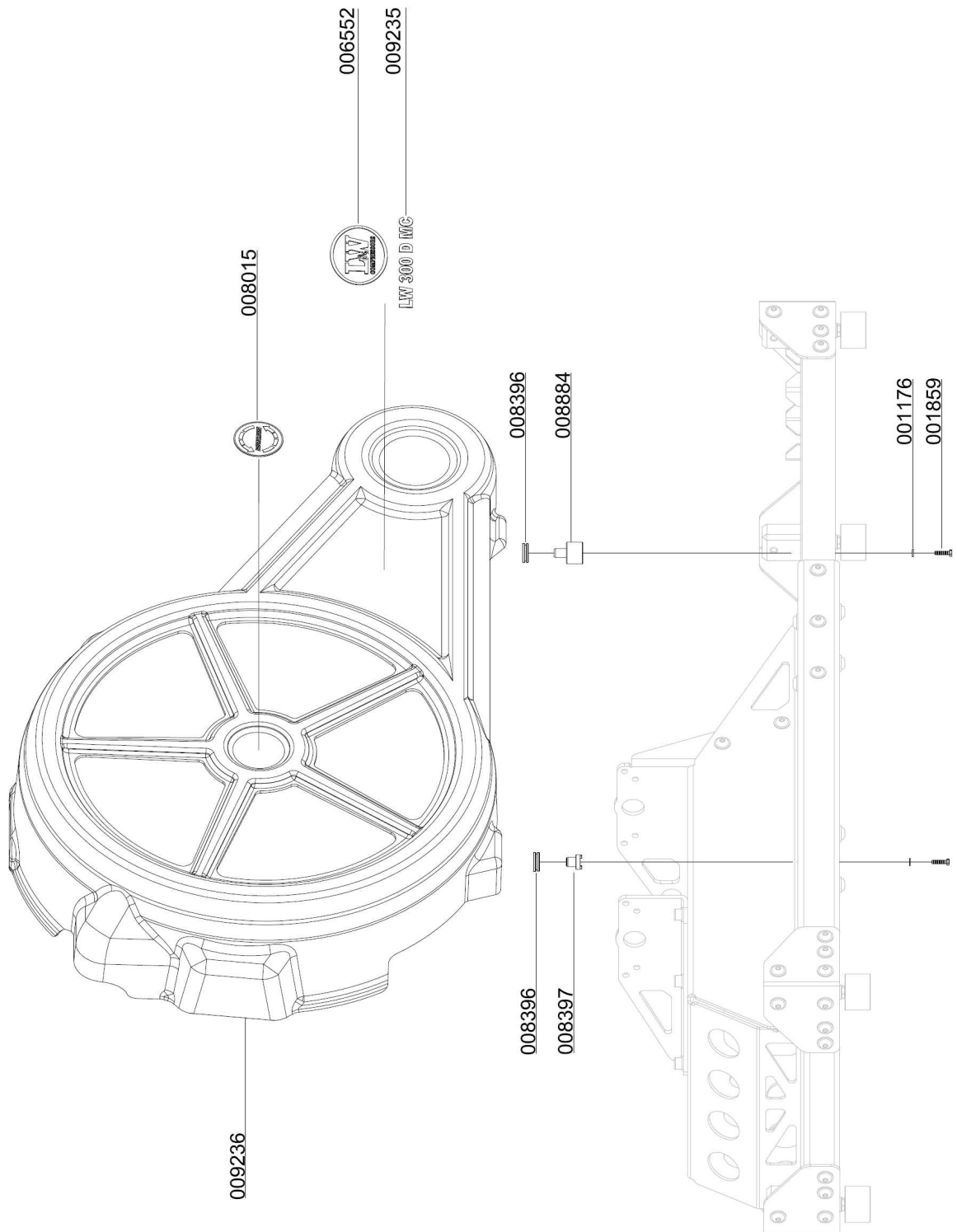

C

DETAILANSICHT / DETAILED VIEW

Baugruppe: Lüfterabdeckung / Assembly: Fan Guard

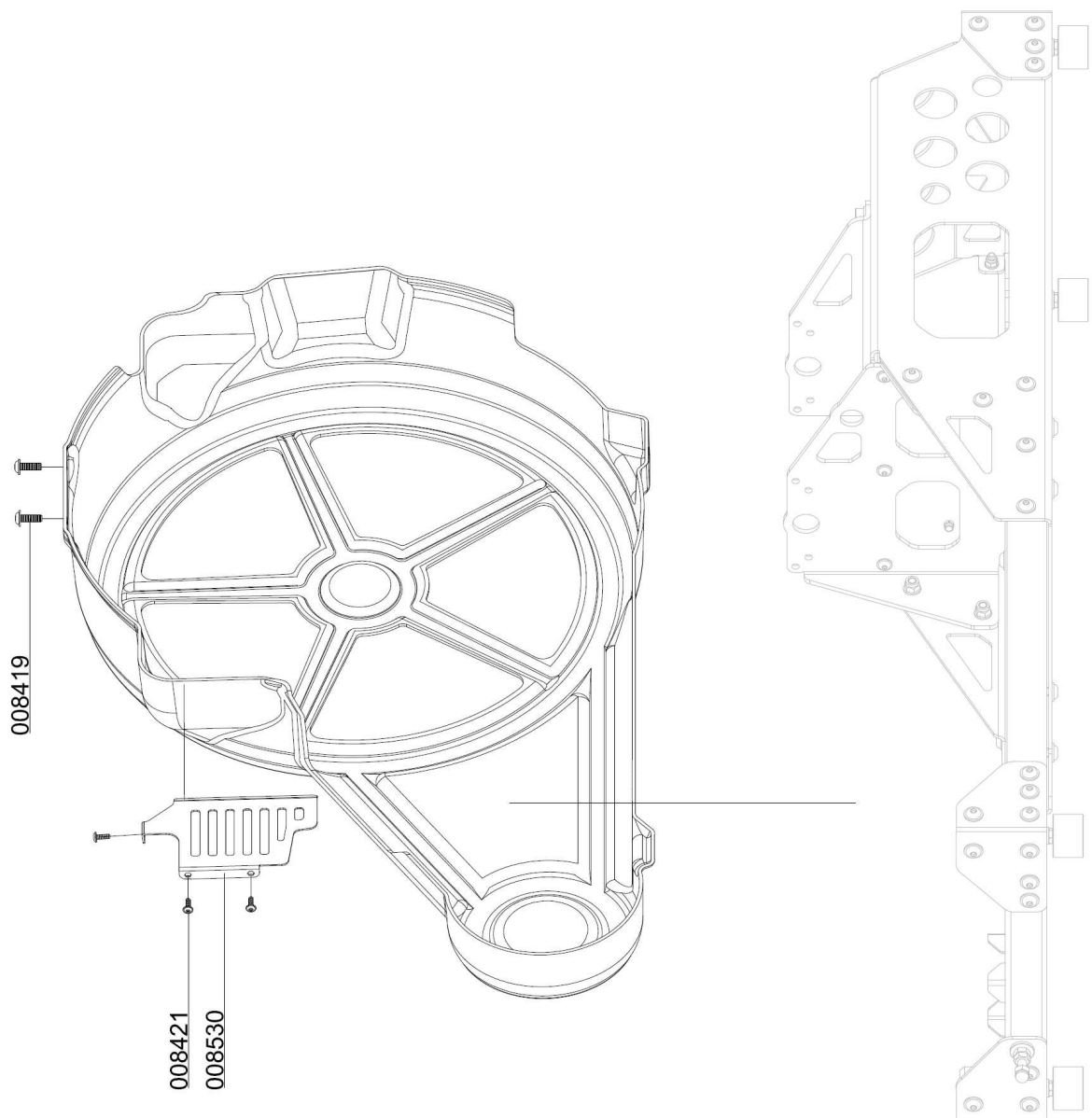



ERSATZTEILLISTE / SPARE PART LIST

Baugruppe: Quertraverse Füllventil / Assembly: Transverse Traverse Filling Valve

Best.-Nr. / Order No.	Benennung	Description
000663	Einbaumanometer mit Befestigungsbügel	Press. Gauge c/w fixing strap
001176	U-Scheibe A5	Washer A5
006254	Füllventilhalter	Filling Valve Holder
006341	Sechskant-Blechschrabe Ø5,5x13mm DIN7976	Sheet Metal Screw Ø5,5x13mm DIN7976
007694	Blende für Einbaumanometer Ø63 mm	Cover Bezel for Ø63 mm gauges
008389	Quertraverse Füllventil	Transv. traverse (fil. valve)

C

DETAILANSICHT / DETAILED VIEW

Baugruppe: Quertraverse Füllventil / Assembly: Transverse Traverse Filling Valve

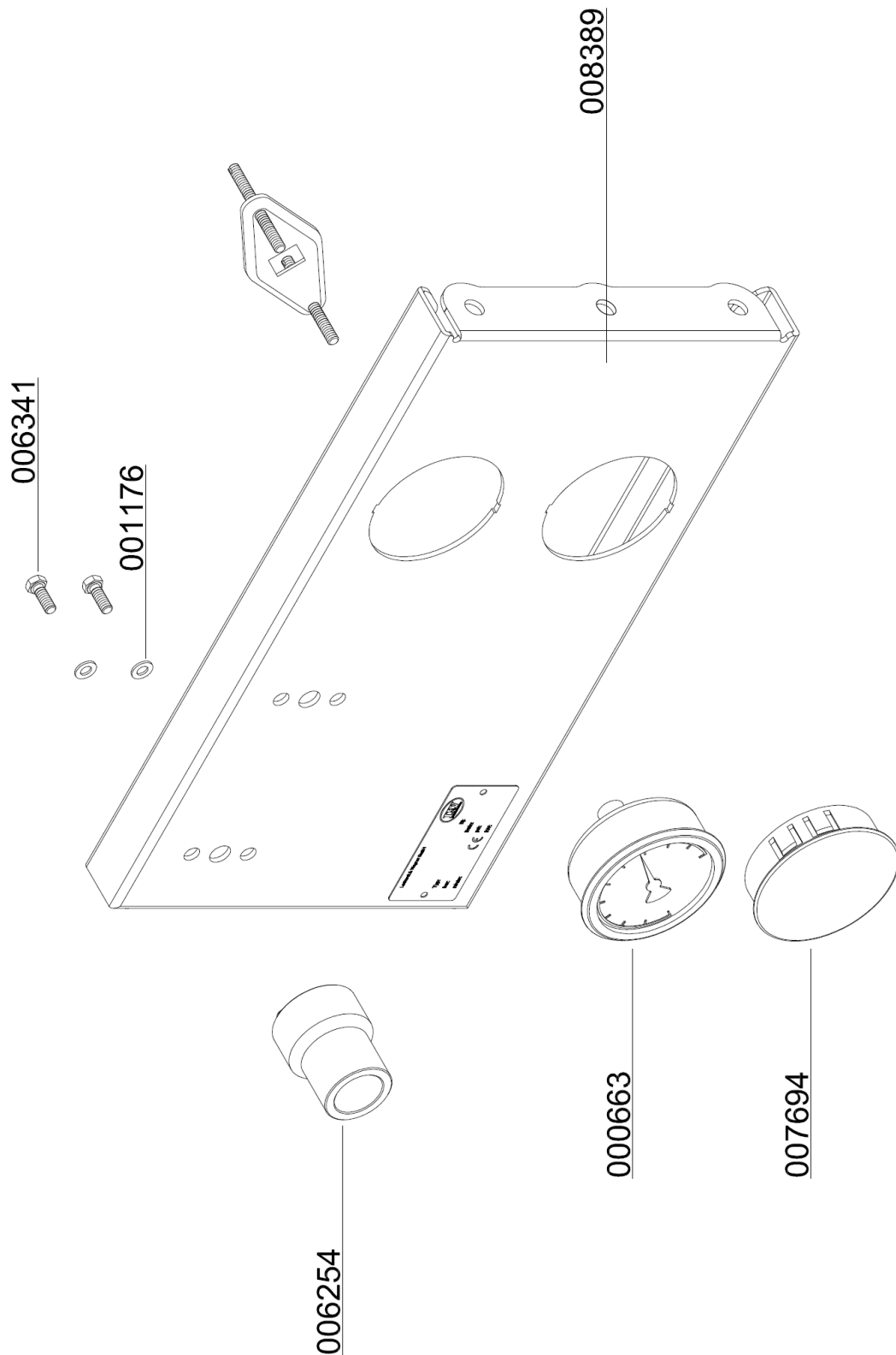

C



ERSATZTEILLISTE / SPARE PART LIST

Baugruppe: Hochdruckabgang / Assembly: High Pressure Outlet

Best.-Nr. / Order No.	Benennung	Description
000213	Handrad, schwarz DIN 477	Hand Wheel DIN 200 bar, black
000215	Handrad rot DIN 477	Hand Wheel DIN 300 bar, red
000386	Gleitscheibe, Kreuzventil	Slide Washer
000387	Feder (Kreuzventil)	Coil Spring, cross d. valve
000696	Füllanschluss o. Handrad	Filling Connect. w/o handwheel
000698	Füllanschluss o. Handrad 300bar	Filling Connec. w/o handwheel
000709	Füllventil Kreuzbauweise, kompl.	Filling Valve cross design
000738	Verschraubung	Connection
000779	Verschlussstopfen 1/4"	Plug 1/4"
000783	Verschraubung	Straight Connection
000785	Verschraubung	Connection tapered
001022	Zylinderschraube	Allen Bolt
001152	Stopfmutter	Lock Nut M5
001176	U-Scheibe A5	Washer A5
001237	O-Ring DIN Flaschenanschluss	O-Ring DIN filling connector
001391	O-Ring	O-Ring
001392	Füllhandrad Kreuzventil	Hand Wheel Filling Valve cross
001393	Entlüftungsspindel	Vent Spindle
001394	Entlüftungshandrad	Vent Hand Wheel
001395	Gleitscheibe, schwarz, Kreuzventil	Slide Washer, plastic black
001397	Kupferdichtung	Copper Seal Ring
001398	Madenschraube	Worm Screw
001399	Oberspindel	Adapter Shaft
001400	Dichtspindel, Kreuzventil	Seal Spindle Filling Valve
001401	Schlitzmutter	Slotted Nut
001402	Gehäuseverschraubung kompl. m. O-	Filling Spindle Body
002023	Füllventil Kreuzbauweise	Filling Valve cross design
002024	Füllventil Kreuzbauweise	Filling Valve cross
002812	Verschraubung, Edelstahl	Connection, S/S



ERSATZTEILLISTE / SPARE PART LIST

Baugruppe: Hochdruckabgang / Assembly: High Pressure Outlet

Best.-Nr. / Order No.	Benennung	Description
003684	Füllventil Kreuzbauweise	Filling Valve cross
003685	Füllventil Kreuzbauweise	Filling Valve cross
008257	Verteilerblock 5xG1/4"	Distributor Block 5xG1/4"
008258	Verteilerblock 2xG1/4"	Distributor Block 2xG1/4"
008979	Manometerschlauch 1560 mm	Pressure Gauge Hose 1560 mm
008980	Hochdruckschlauch 1340mm	HP-Hose, Length: 1340 mm
008982	Verbindungsrohr, VA Ø8mm	Connecting Pipe, c/w nut+olive
008995	Winkelverschraubung	Elbow Connection

C

DETAILANSICHT / DETAILED VIEW

Baugruppe: Hochdruckabgang / Assembly: High Pressure Outlet

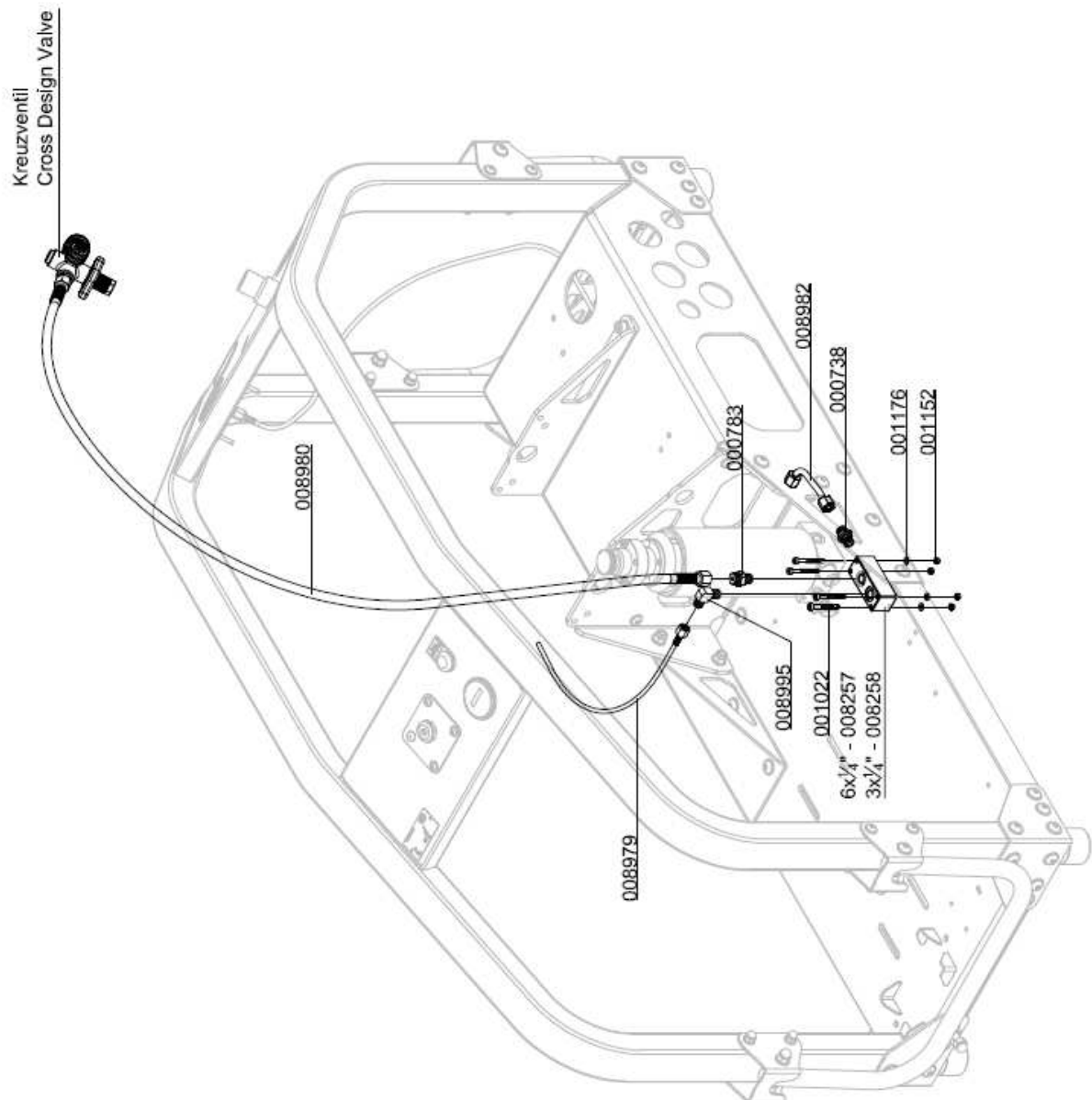

C

DETAILANSICHT / DETAILED VIEW

Baugruppe: Hochdruckabgang / Assembly: High Pressure Outlet

Kreuzventil komplett
 Compl. Cross Design Valve

200 bar - 003684 Drehanschluss (swivel connector)
 300 bar - 003685 Drehanschluss (swivel connector)
 200 bar - 002023 starr (fixed)
 300 bar - 002024 starr (fixed)

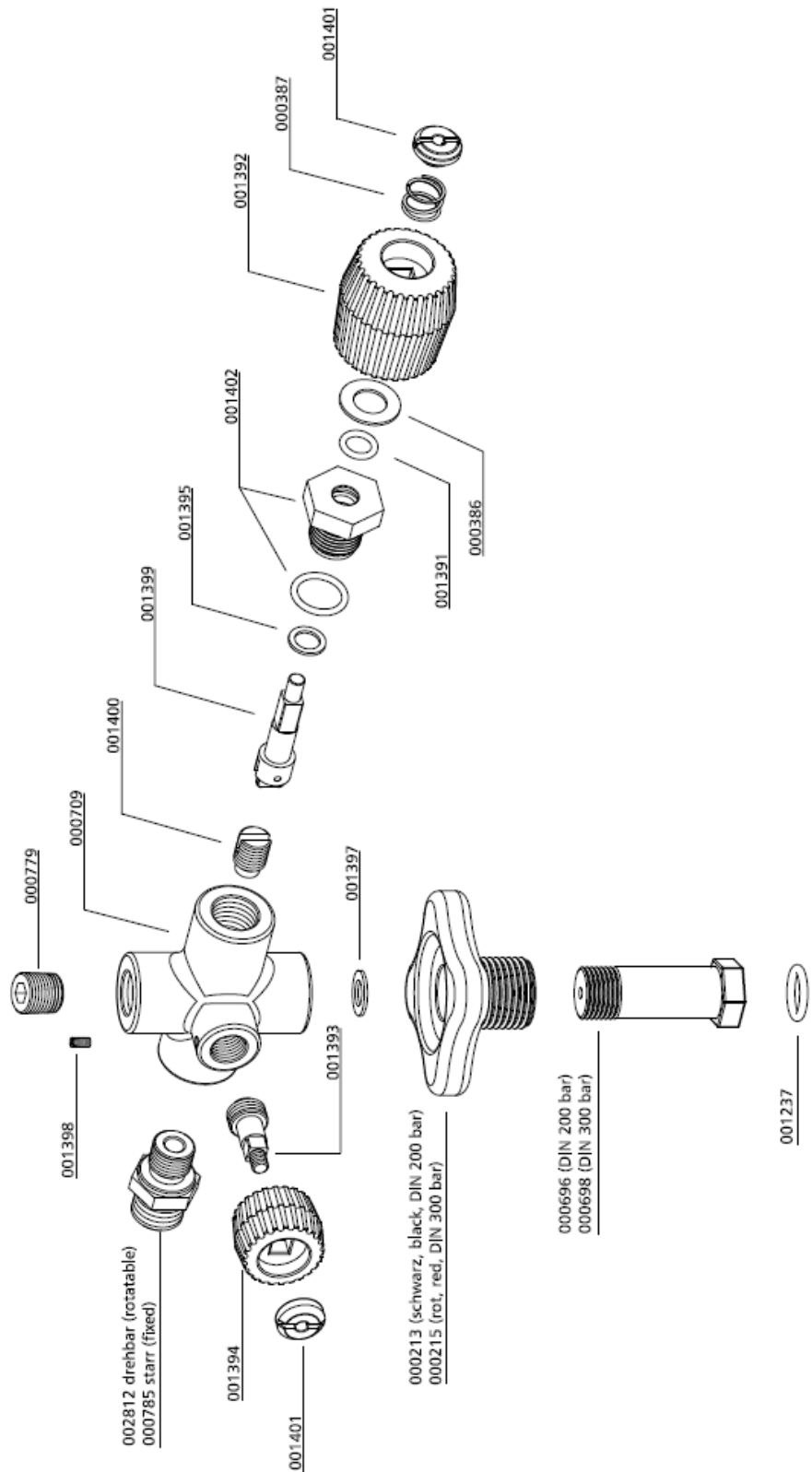



ERSATZTEILLISTE / SPARE PART LIST

Baugruppe: Motor / Assembly: Engine

Best.-Nr. / Order No.	Benennung	Description
001039	Zylinderschraube	Allen Bolt
001105	6-kant Schraube	Hexagon Bolt
001106	6-kant Schraube	Hexagon Bolt
001163	Mutter	Nut M10
001164	Stopfmutter	Lock Nut M10
001181	U-Scheibe A8	Washer A8
001186	U-Scheibe A10	Washer A10
001187	U-Scheibe A10	Washer A10
002513	Hutmutter M10	Cap nut M10
008838	Riemenscheibe	V-belt pulley for motor 7.5 kW
008968	Spannbuchse für Riemenscheibe	Pulley Clamp Bush
009008	Passfeder	Woodruff Key
009245	Schraube mit Scheibe, M8x20	Screw with Washer
009246	Befestigungsklotz Spannschraube	Fixing Block Tensioning Bolt
009247	Antriebsmotor 7,4kW	Diesel Engine 7,4kW
009279	Auspuff	Exhaust LW 300 D MC
009281	Gelenkbolzenschelle	Hinge Bolt Clamp
009467	Keilriemen	V-Belt

C

DETAILANSICHT / DETAILED VIEW

Baugruppe: Motor / Assembly: Engine

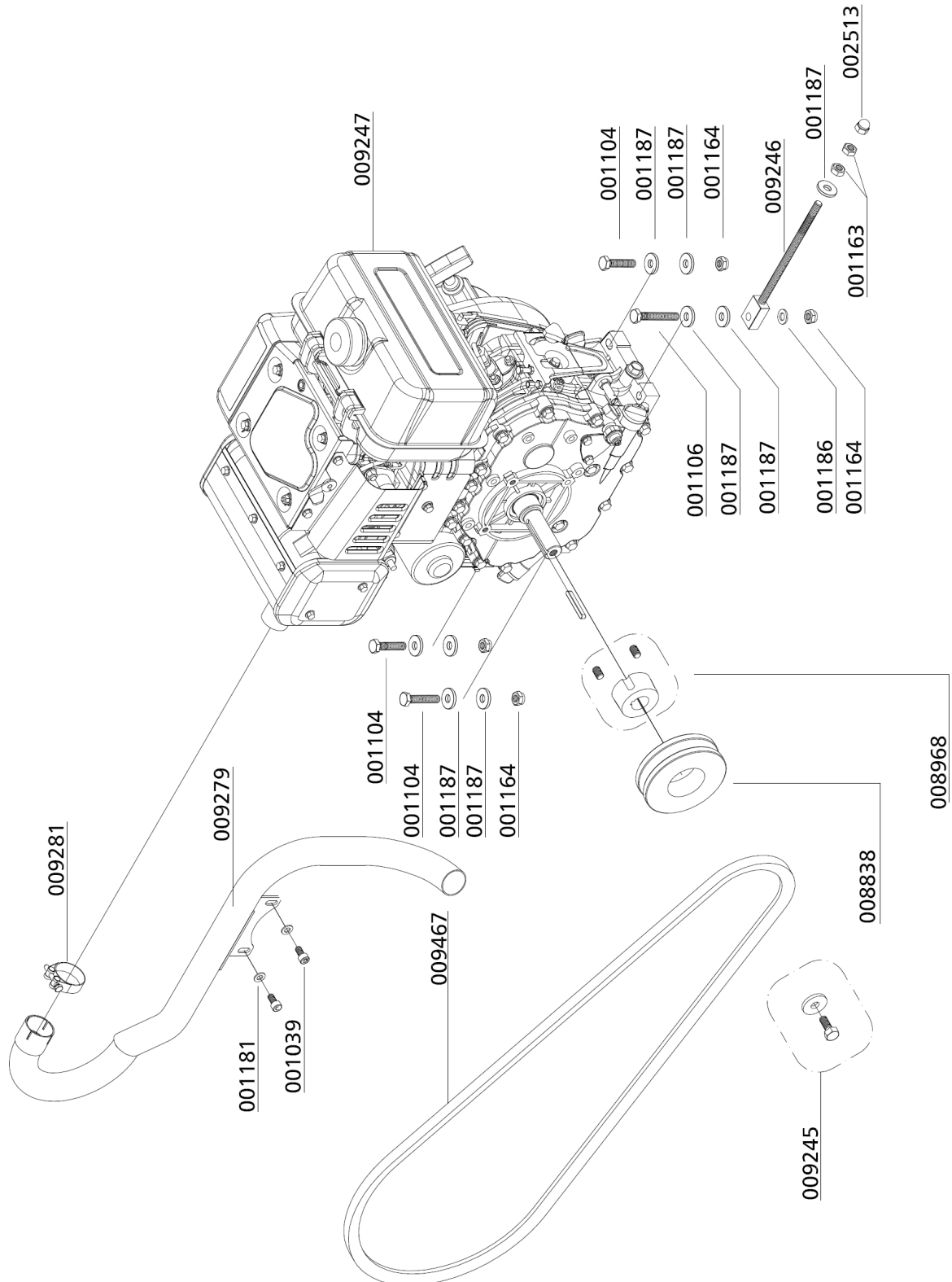



ERSATZTEILLISTE / SPARE PART LIST

Baugruppe: Kompressorblock / Assembly: Compressor Block

Best.-Nr. / Order No.	Benennung	Description
000227	Sicherheitsventil G3/8"	Safety Valve G3/8" 8 bar
000498	U-Scheibe A6	Washer A6
000712	Verschraubung	Connection w/o nut & olive seal
000715	Verschraubung	Connection w/o nut & olive seal
000732	Mutter 06L	Union Nut 06L
000733	Schneidring 6 mm	Olive Seal SR 06 (Ø 6mm)
000734	Mutter 06S	Nut 06S
000738	Verschraubung	Connection
000741	Verschraubung	Connection
000805	Verschraubung	Connection
000837	Verschlussstopfen	Plug
000863	Winkelverschraubung 90°	Elbow Connection
000864	Verschraubung	Connection
000866	Verschraubung	Connection
000952	Sechskantschraube M6x20mm DIN933	Hexagon Screw M6x20mm DIN933
000960	Stiftschraube M8x20mm DIN939	Threaded Stud M8x20mm DIN939
001041	Zylinderschraube M8x25mm DIN912	Allen Screw M8x25mm DIN912
001042	Zylinderschraube M8x30mm DIN912	Allen Screw M8x30mm DIN912
001046	Zylinderschraube M8x50mm DIN912	Allen Screw M8x50mm DIN912
001056	Zylinderschraube M8x60mm DIN912	Allen Screw M8x60mm DIN912
001058	Zylinderschraube M8x70mm DIN912	Allen Screw M8x70mm DIN912
001083	Sechskant Schraube M8x30mm DIN933	Hexagon Screw M8x30mm DIN933
001158	Mutter M8	Nut M8
001181	U-Scheibe A8	Washer A8
001186	U-Scheibe A10	Washer A10
001362	Sicherungsring I 72 DIN472	Circlip I 72 DIN472
001710	Oeleinfüllstutzen	Oil Filler Neck
001775	O-Ring, Oelmessstab	O-Ring, oil dipstick
001778	O-Ring, Oeleinfüllrohr	O-Ring, oil filler pipe



ERSATZTEILLISTE / SPARE PART LIST

Baugruppe: Kompressorblock / Assembly: Compressor Block

Best.-Nr. / Order No.	Benennung	Description
002124	Ventilkopf 3. Stufe	Valve head 3rd Stage
003766	Aludichtring für G3/8" Gewinde	Alloy Seal Ring for G3/8" male
005109	O-Ring	O-Ring
005856	Winkeleinschraubverschraubung 8 mm	Elbow Hose Connection 8 mm
006383	O-Ring	O-Ring
006846	Schlauchschelle	Hose clamp
007043	Kondensatschlauch 5,4x9,4	Condensate Hose 5.4x9.4 mm
007768	Sicherungsring I 18 DIN472	Circlip I 18 DIN472
007899	O-Ring	O-Ring
007901	O-Ring	O-Ring
007902	O-Ring	O-Ring
007903	O-Ring	O-Ring
007904	Radial-Wellendichtring	Shaft seal
007912	Saug-Druckventil 2. Stufe	In & Outlet Valve 2nd Stage
007913	Saug-Druckventil 1. Stufe	In & Outlet Valve 1st Stage
007914	Kurbelgehäuse	Crankcase
007915	Deckel ölpumpenseitig	Cover oil pump side
007916	Deckel schwungradseitig	Cover flywheel side
007917	Deckel zu Ölfilter	Cover oil filter
007920	Ölpeilstab	Dipstick
007926	Zylinder 2.Stufe	Cylinder 2.Stage
007927	Ventilkopf 2. Stufe	Valve Head 2nd Stage
007929	Zylinder 1.Stufe	Cylinder 1st Stage
007931	Ventilkopf 1. Stufe	Valve Head 1st Stage
007933	Führungskolben 3.Stufe	Guide Piston 3rd Stage
007936	Zylinder 3.Stufe	Cylinder 3rd Stage
007943	Führungskolben 2.Stufe	Guide Piston 2nd Stage
007944	Kolbenbolzen 2. & 3. Stufe	Piston Pin, 2. +3. Stage
007945	Obere Ventildichtung für Ventil 2.Stufe	Upper Valve Gasket, Paper, 2nd

C



ERSATZTEILLISTE / SPARE PART LIST

Baugruppe: Kompressorblock / Assembly: Compressor Block

Best.-Nr. / Order No.	Benennung	Description
007946	Obere Ventildichtung für Ventil 1.Stufe	Upper Valve Gasket, Paper, 1st
007948	Dichtung zu Ölfliter	Gasket for oil filter
007971	Halterung Wasserabscheider 2. Stufe	Bracket water separator 2. S.
008239	Ölfilter	Oil Filter Element
008344	Untere Halterung Kühlrohr/ Lüfterabdeckung	Lower Holder Fan Guard
008345	Obere Halterung Kühlrohr/ Lüfterabdeckung	Upper Holder Fan Guard
008606	VA Rohr "Ölfilter-2.Stufe Führungszyl."	Pipe
008607	VA Rohr "Ölfilter-3.Stufe Führungszyl."	Pipe
008650	Druckfeder Ölfilter	Coil Spring - oil filter
008696	6kt-Schraube M10x30mm	Hexagon Screw M10x30mm

C



ERSATZTEILLISTE / SPARE PART LIST

Baugruppe: Kurbeltrieb / Assembly: Crank Drive

Best.-Nr. / Order No.	Benennung	Description
001048	Zylinderschraube	Allen Screw
001343	Sicherungsring A35 DIN471	Circlip A35 DIN 471
007910	Passfeder DIN 6885 A10x8x32	Woodruff Key DIN 6885 A10x8x32
007925	Distanzring zu Kurbelwelle	Distance ring, crankshaft
007941	Distanzscheibe, Pleuel	Distance washer, conrod
007942	Distanzscheibe, Kurbelwelle	Distance washer, crankshaft
007976	Zylinderrollenlager	cylindrical roller bearing
007977	Zylinderrollenlager	cylindrical roller bearing
007978	Nadelhülse	needle bush
008793	Pleuel 1.Stufe	Conrod c/w Needle Bearing
008794	Pleuel 2. & 3. Stufe	Conrod c/w Needle Bearings
008795	Kurbelwelle, inkl. Gegengewicht	Crankshaft with Counter Weight
008796	Kurbeltrieb komplett	Crank Drive complete

C

DETAILANSICHT / DETAILED VIEW

Baugruppe: Kurbeltrieb / Assembly: Crank Drive

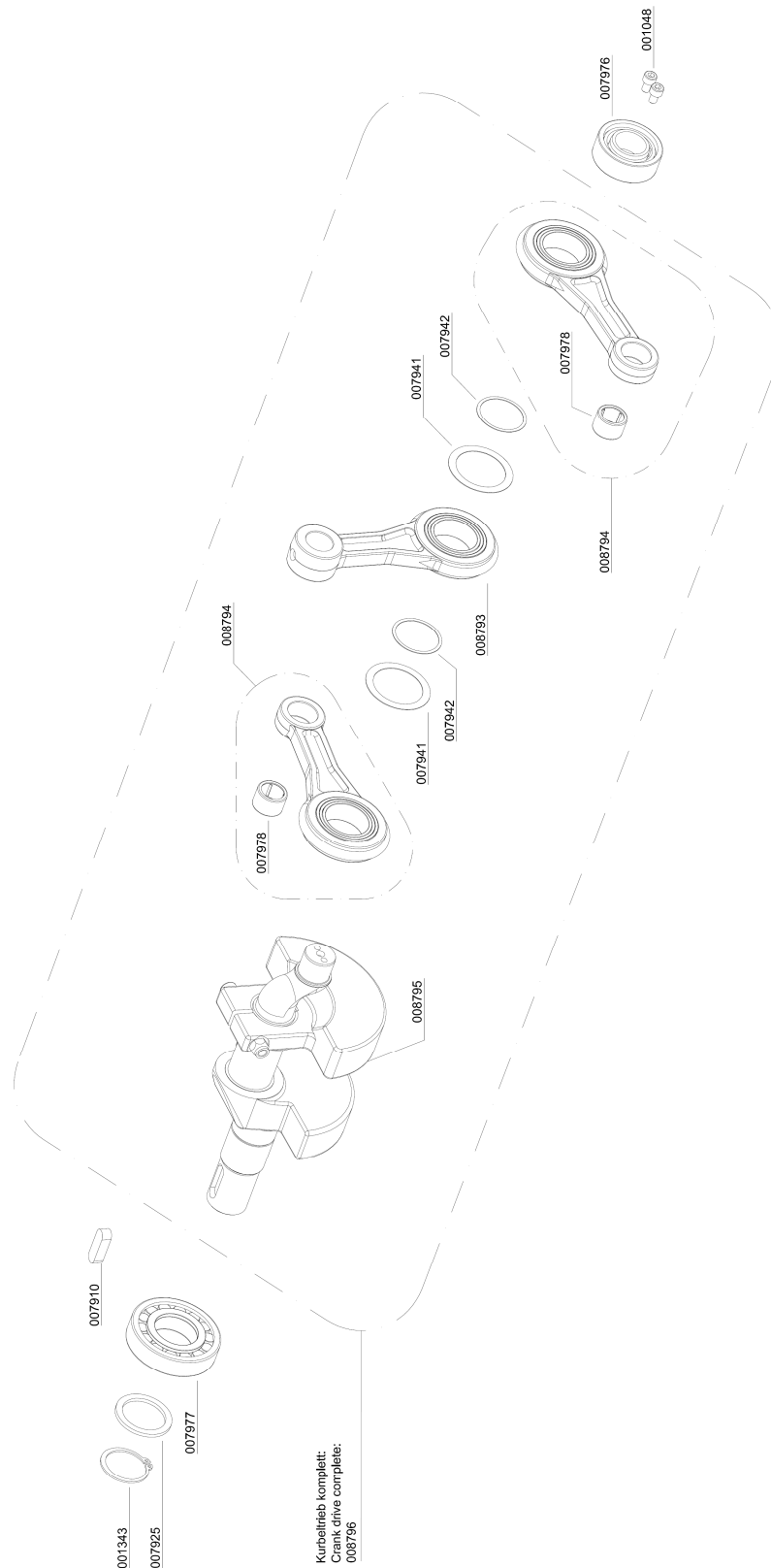

C



ERSATZTEILLISTE / SPARE PART LIST

Baugruppe: Kolben 1. Stufe / Assembly: Piston 1st Stage

Best.-Nr. / Order No.	Benennung	Description
007973	Kolben inkl. Kolbenringe, Bolzen 1. St.	Piston, compl. 1st Stage
008799	Kolbenringe 1.Stufe Satz	Piston Rings 1st Stage

C

DETAILANSICHT / DETAILED VIEW

Baugruppe: Kolben 1. Stufe / Assembly: Piston 1st Stage

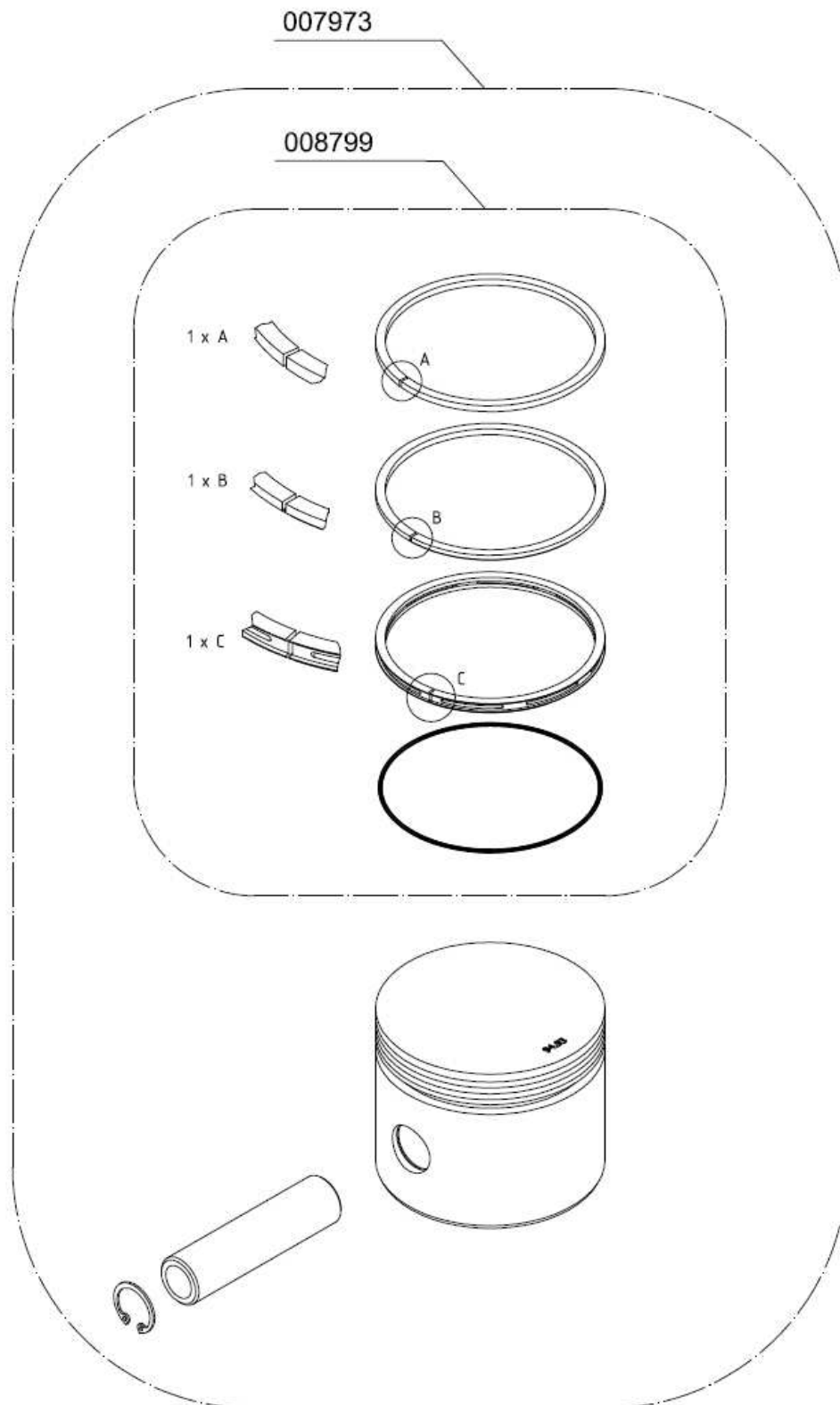

C



ERSATZTEILLISTE / SPARE PART LIST

Baugruppe: Kompressionskolben 2. Stufe / Assembly: Compression Piston 2nd Stage

Best.-Nr. / Order No.	Benennung	Description
008800	Kolbenringe 2.Stufe Satz	Piston Rings 2nd Stage
008802	Kompressionskolben 2.Stufe	Compression Piston 2nd Stage

C

DETAILANSICHT / DETAILED VIEW

Baugruppe: Kompressionskolben 2. Stufe / Assembly: Compression Piston 2nd Stage

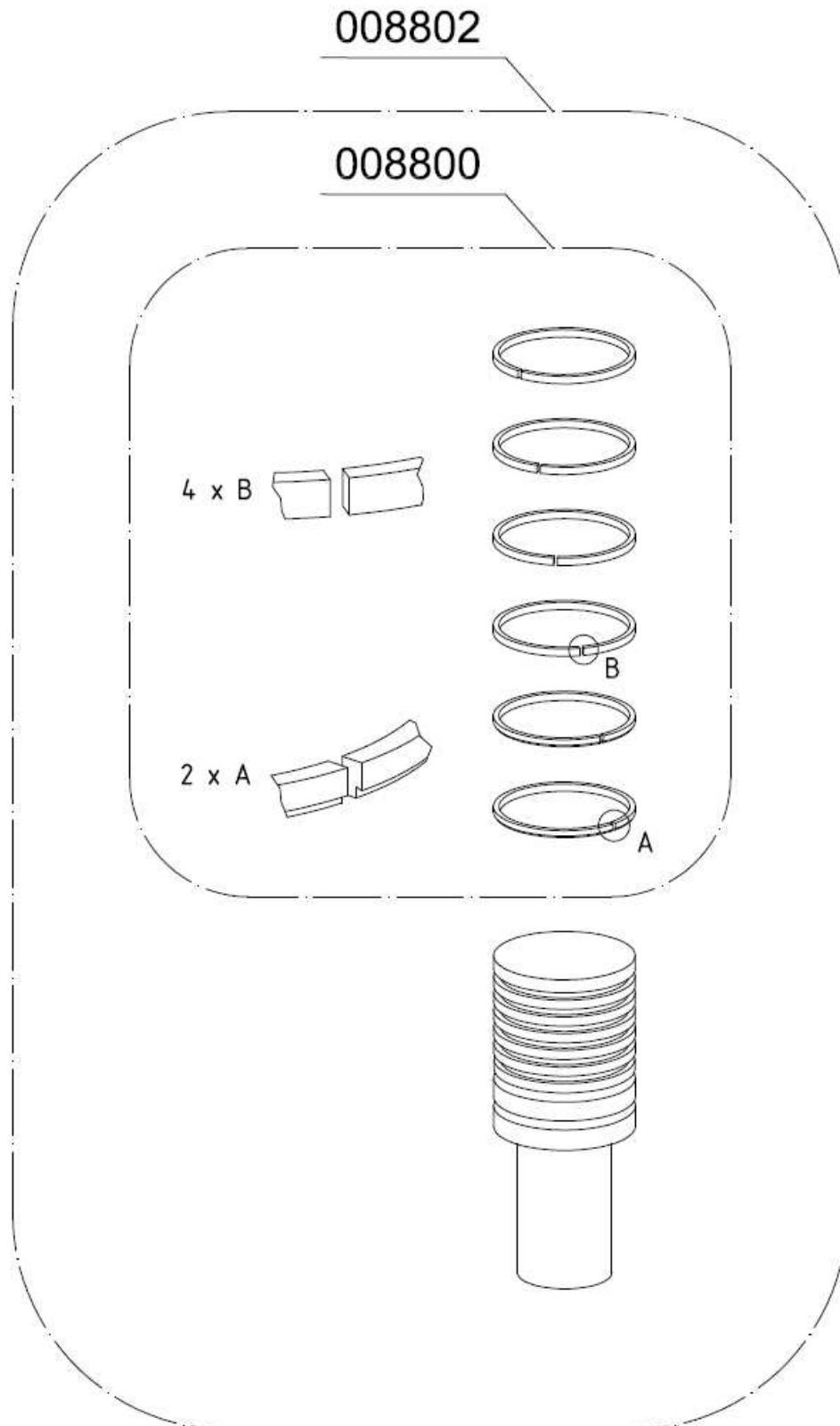



ERSATZTEILLISTE / SPARE PART LIST

Baugruppe: Kompressionskolben 3. Stufe / Assembly: Compression Piston 3rd Stage

Best.-Nr. / Order No.	Benennung	Description
008801	Kolbenringe 3.Stufe Satz	Piston Rings 3rd Stage
008803	Kompressionskolben 3.Stufe	Compression Piston 3rd Stage

C

DETAILANSICHT / DETAILED VIEW

Baugruppe: Kompressionskolben 3. Stufe / Assembly: Compression Piston 3rd Stage

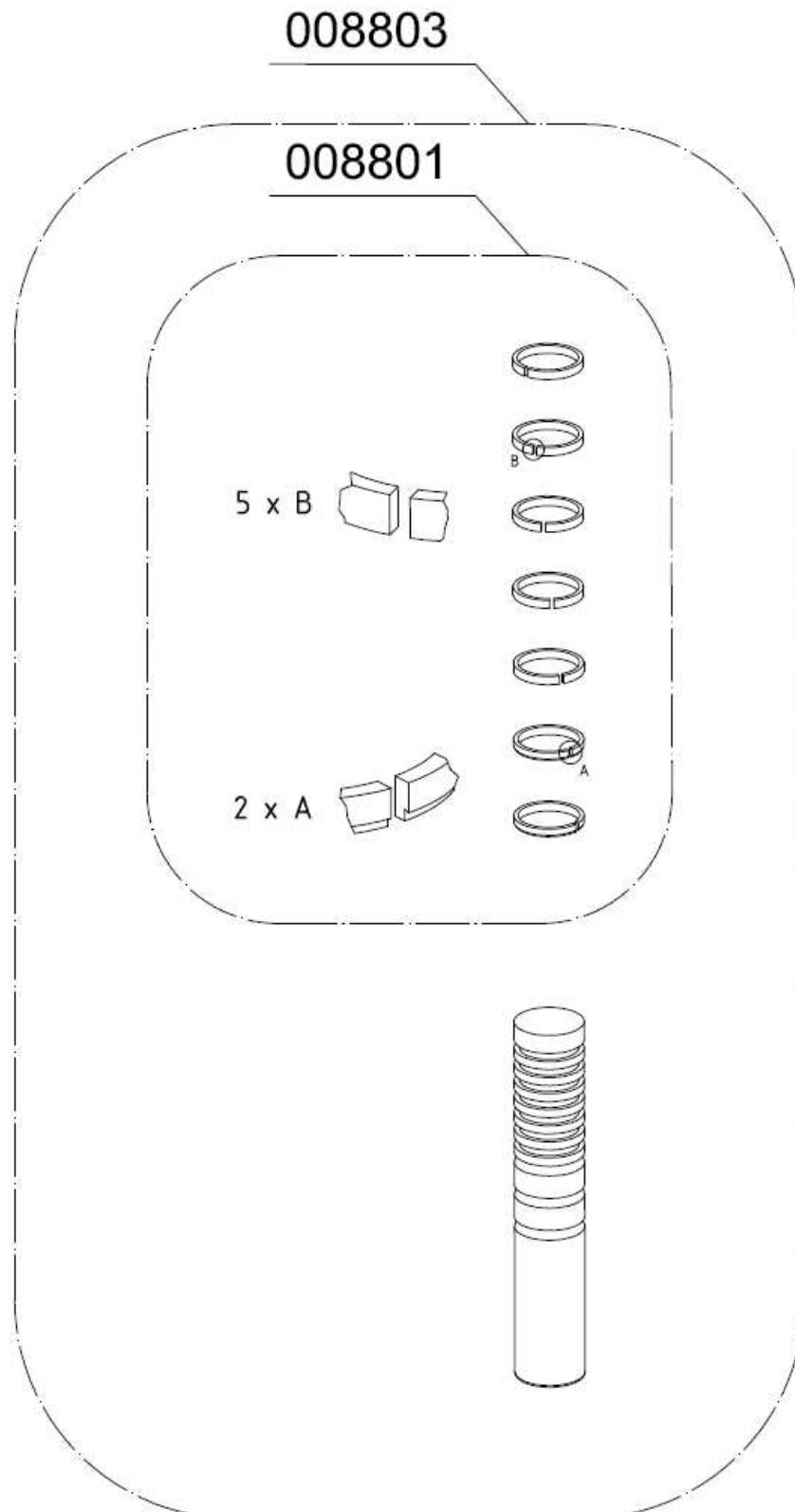

C



ERSATZTEILLISTE / SPARE PART LIST

Baugruppe: Saug & Druckventil 1. & 2. Stufe / Assembly: In & Outlet Valve 1st & 2nd Stage

Best.-Nr. / Order No.	Benennung	Description
007912	Saug-Druckventil 2. Stufe	In & Outlet Valve 2nd Stage
007913	Saug-Druckventil 1. Stufe	In & Outlet Valve 1st Stage

C

DETAILANSICHT / DETAILED VIEW

Baugruppe: Saug & Druckventil 1. & 2. Stufe / Assembly: In & Outlet Valve 1st & 2nd Stage

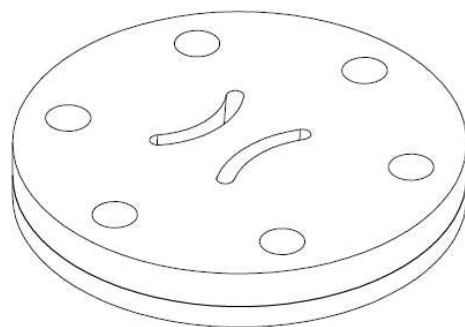

007912

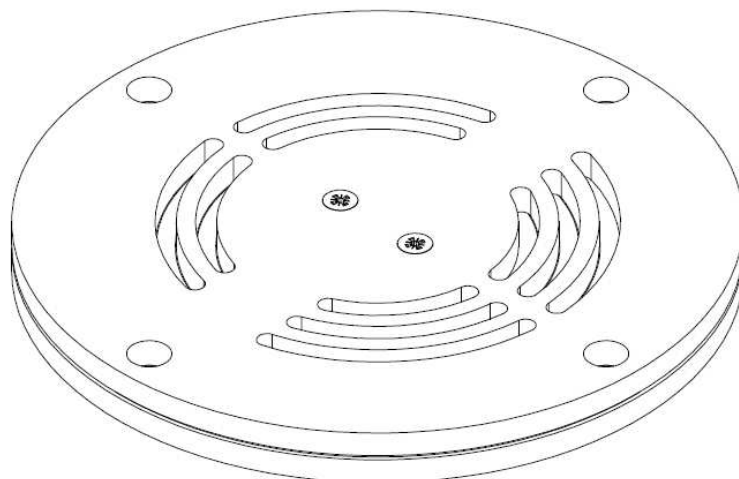

007913

C



ERSATZTEILLISTE / SPARE PART LIST

Baugruppe: Saug & Druckventil 3. Stufe / Assembly: In & Outlet Valve 3rd Stage

Best.-Nr. / Order No.	Benennung	Description
000531	Ventildichtung, Saug-& Druckventil unten	Lower Valve Gasket, 4th St.
000541	Dichtring / Dichtung Ventil 3./4. Stufe	Upper Alloy Seal Ring
008823	Saug- & Druckventil, 3. Stufe komplett	In- & Outlet Valve, 3rd Stage

C

DETAILANSICHT / DETAILED VIEW

Baugruppe: Saug & Druckventil 3. Stufe / Assembly: In & Outlet Valve 3rd Stage

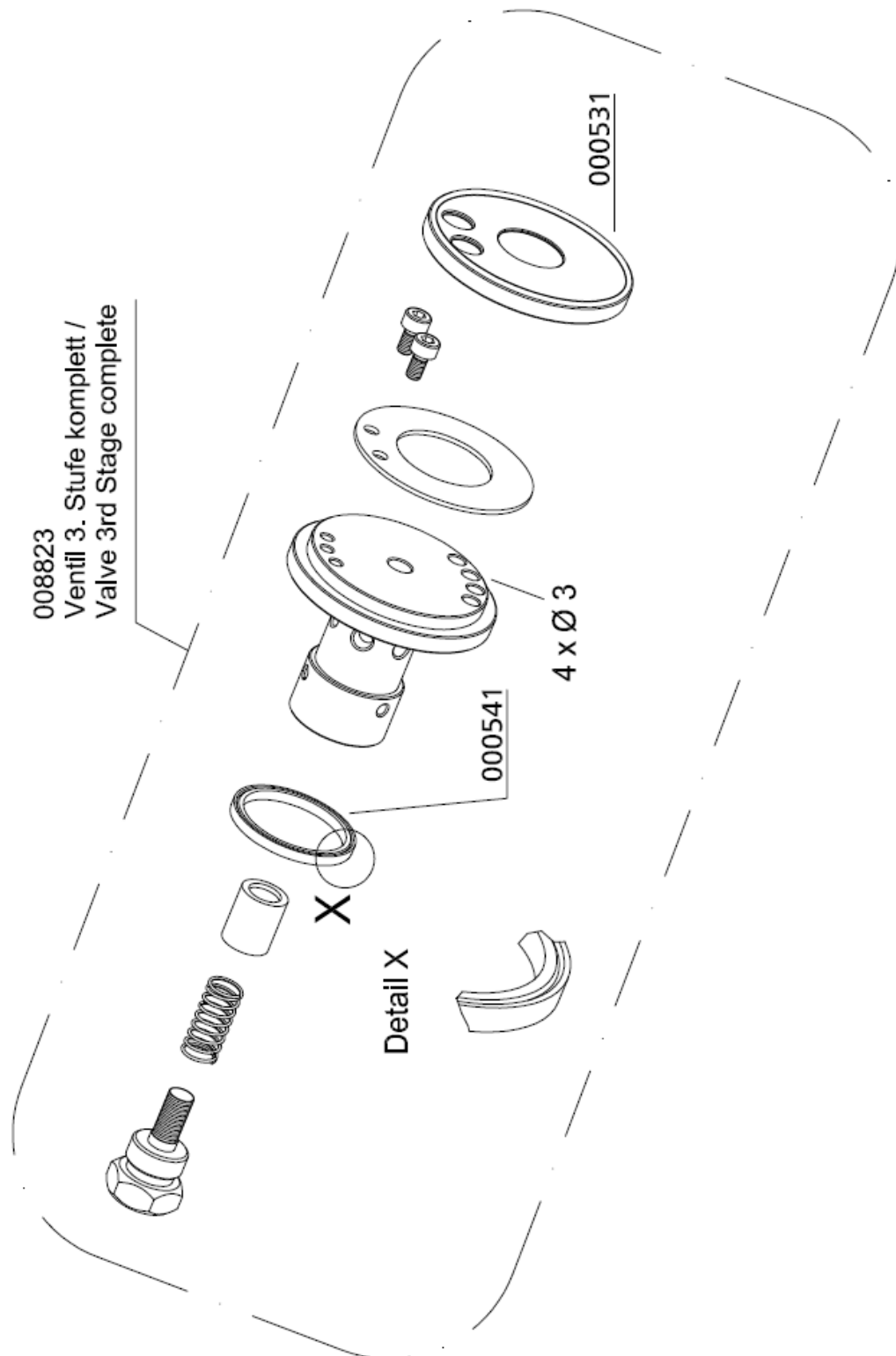

C



ERSATZTEILLISTE / SPARE PART LIST

Baugruppe: Kühler 1. Stufe / Assembly: Cooler 1st Stage

Best.-Nr. / Order No.	Benennung	Description
000861	Schneidring 18 mm	Olive Seal 18 mm
000862	Mutter 18L	Union Nut 18L
001005	Zylinderschraube M5x16mm DIN912	Allen Screw M5x16mm DIN912
001006	Zylinderschraube M5x20mm DIN912	Allen Screw M5x20mm DIN912
001176	U-Scheibe A5	Washer A5
008222	Rippenrohrkühler 1. Stufe	Finned Cooler Pipe 1st Stage
008497	Rohrschelle Ø21	Pipe Clamp Ø21

C

DETAILANSICHT / DETAILED VIEW

Baugruppe: Kühler 1. Stufe / Assembly: Cooler 1st Stage

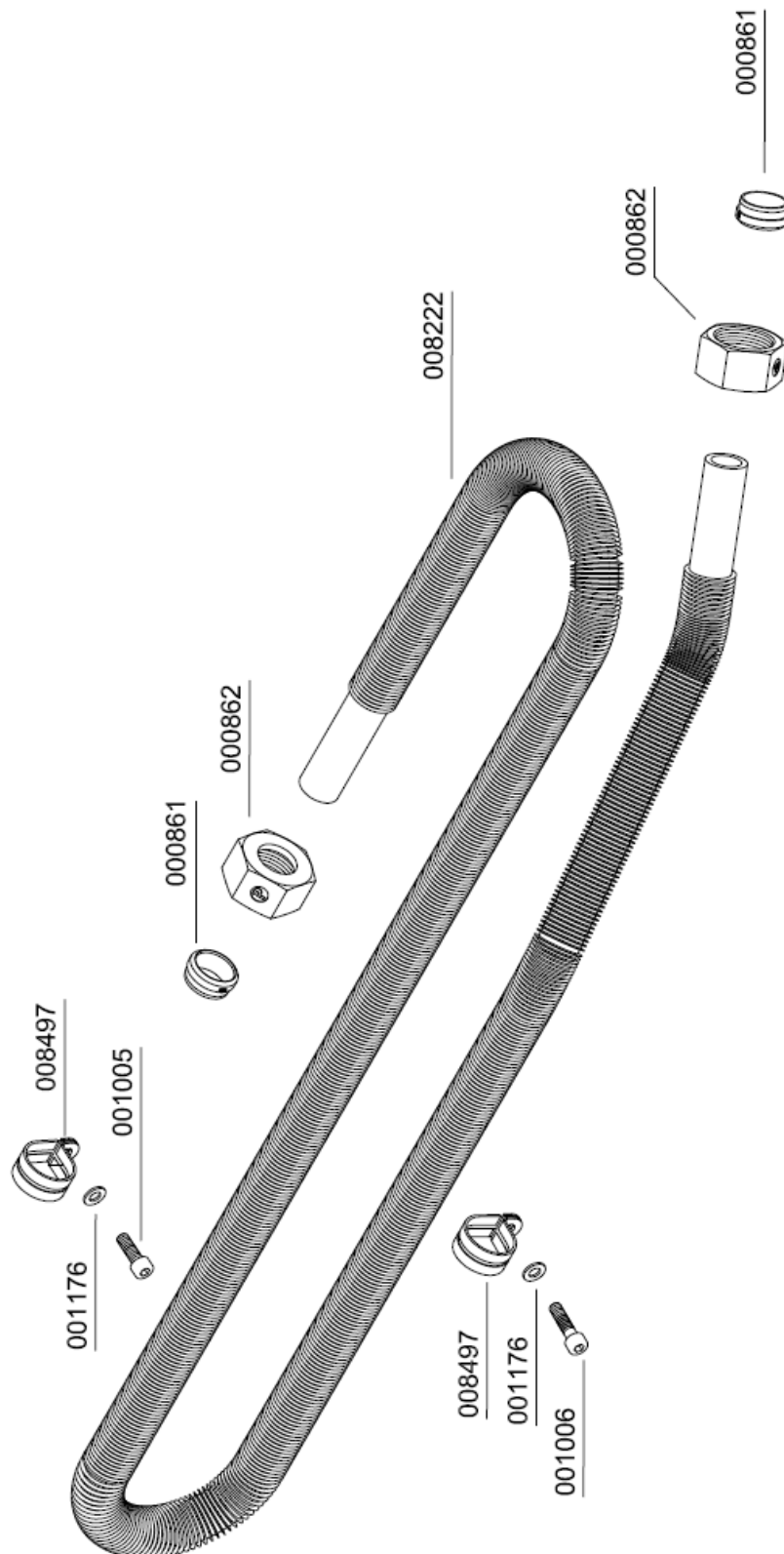

C



ERSATZTEILLISTE / SPARE PART LIST

Baugruppe: Kühler 2. Stufe / Assembly: Cooler 2nd Stage

Best.-Nr. / Order No.	Benennung	Description
000498	U-Scheibe A6	Washer A6
000861	Schneidring 18 mm	Olive Seal 18 mm
000862	Mutter 18L	Union Nut 18L
001013	Zylinderschraube DIN912 M6x45	Allen Bolt DIN912 M6x45
001156	Stopfmutter M6	Lock Nut M6
007967	Kühlrohrklemme 2. Stufe	Cooling Pipe Clamp 2. Stage
008223	Rippenrohrkühler 2.Stufe	finned cooler pipe 2nd Stage
008497	Rohrschelle Ø21	Pipe Clamp Ø21

C

DETAILANSICHT / DETAILED VIEW

Baugruppe: Kühler 2. Stufe / Assembly: Cooler 2nd Stage

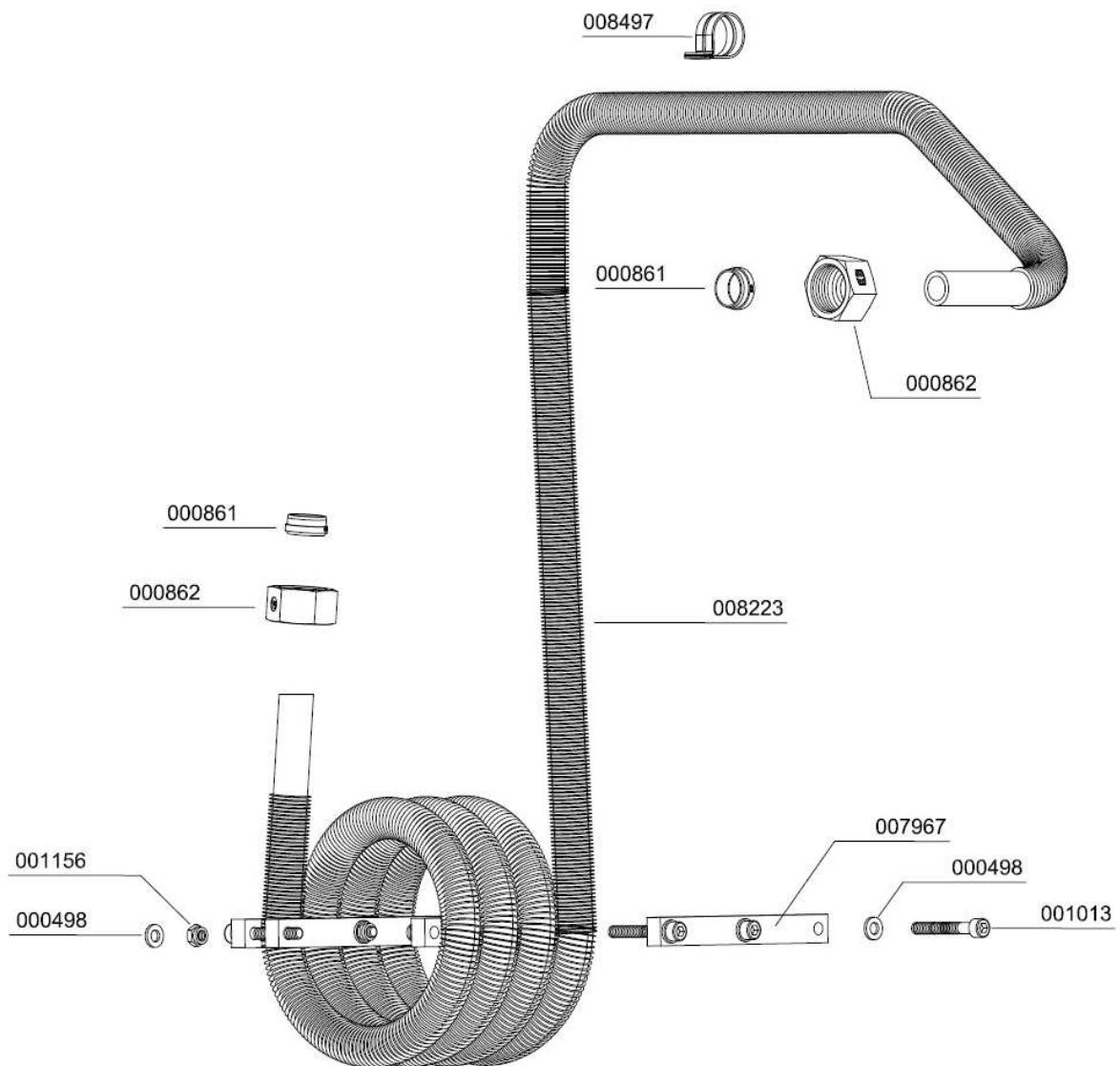

C



ERSATZTEILLISTE / SPARE PART LIST

Baugruppe: Kühler 3. Stufe / Assembly: Cooler 3rd Stage

Best.-Nr. / Order No.	Benennung	Description
000498	U-Scheibe A6	Washer A6
000765	Schneidring 8 mm	Olive Seal 8 mm
000766	Mutter 08L	Nut 08L
001004	Zylinderschraube M5x10mm DIN912	Allen Screw M5x10mm DIN912
001006	Zylinderschraube M5x20mm DIN912	Allen Screw M5x20mm DIN912
001013	Zylinderschraube M6x45mm DIN912	Allen Bolt M6x45mm DIN912
001039	Zylinderschraube M8x16mm DIN912	Allen Screw M8x16mm DIN912
001156	Stopfmutter M6	Lock Nut M6
001176	U-Scheibe A5	Washer A5
001181	U-Scheibe A8	Washer A8
007968	Kühlrohrklemme 3.Stufe 6-fach	Cooling Pipe Clamp 6-fold
008398	Rippenrohrkühler 3. Stufe	finned cooler pipe 3rd Stage
008656	Rohrschelle Ø8mm	P-Clip Ø8mm
008673	Halterung Kühlrohrklemme 3. Stufe	Bracket for Cooling Pipe Clamp
008788	Kühlrohrklemme 3.Stufe 5-fach	Cooling Pipe Clamp 5-fold
008857	Halterung Kühlrohrklemme 3. Stufe	Bracket for Cooling Pipe Clamp

DETAILANSICHT / DETAILED VIEW

Baugruppe: Kühler 3. Stufe / Assembly: Cooler 3rd Stage

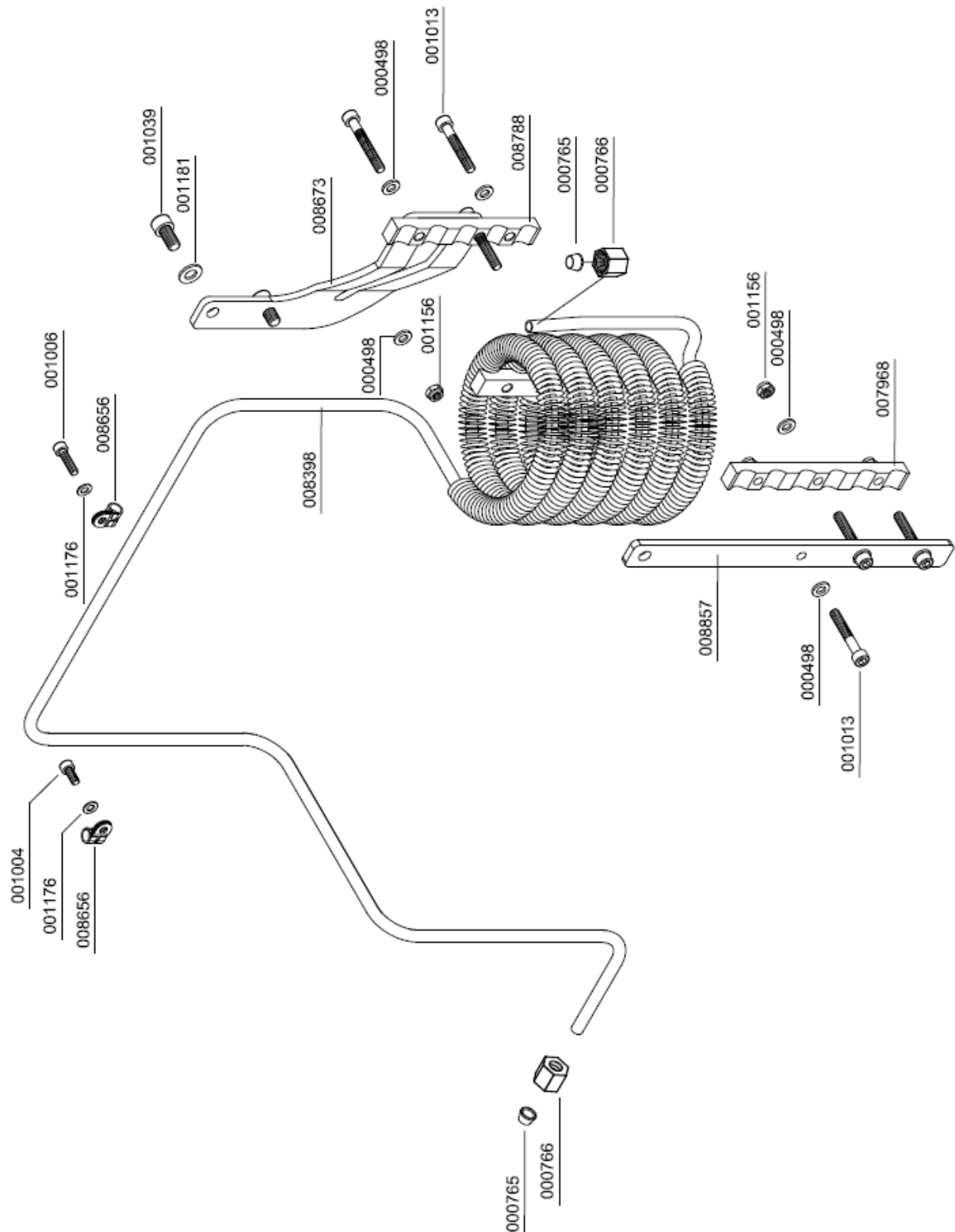

C



ERSATZTEILLISTE / SPARE PART LIST

Baugruppe: Lüfterrad / Assembly: Flywheel Assembly

Best.-Nr. / Order No.	Benennung	Description
001041	Zylinderschraube M8x25mm DIN912	Allen Screw M8x25mm DIN912
001134	Sechskant Schraube M12x35mm DIN933	Hexagon Screw M12x35mm DIN933
001181	U-Scheibe A8	Washer A8
001193	Schnorr-Scheibe S12	Clamp Washer S12
005122	U-Scheibe, Kurbelwelle	Washer, crank shaft
007921	Ventilatorflügelblatt	Fan blade
007923	Schwungrad	Flywheel
007924	Scheibe für Schwungrad	Washer for Flywheel
008862	Haltering Ventilatorflügel	Fan Blade Fixing Ring

C

DETAILANSICHT / DETAILED VIEW

Baugruppe: Lüfterrad / Assembly: Flywheel Assembly

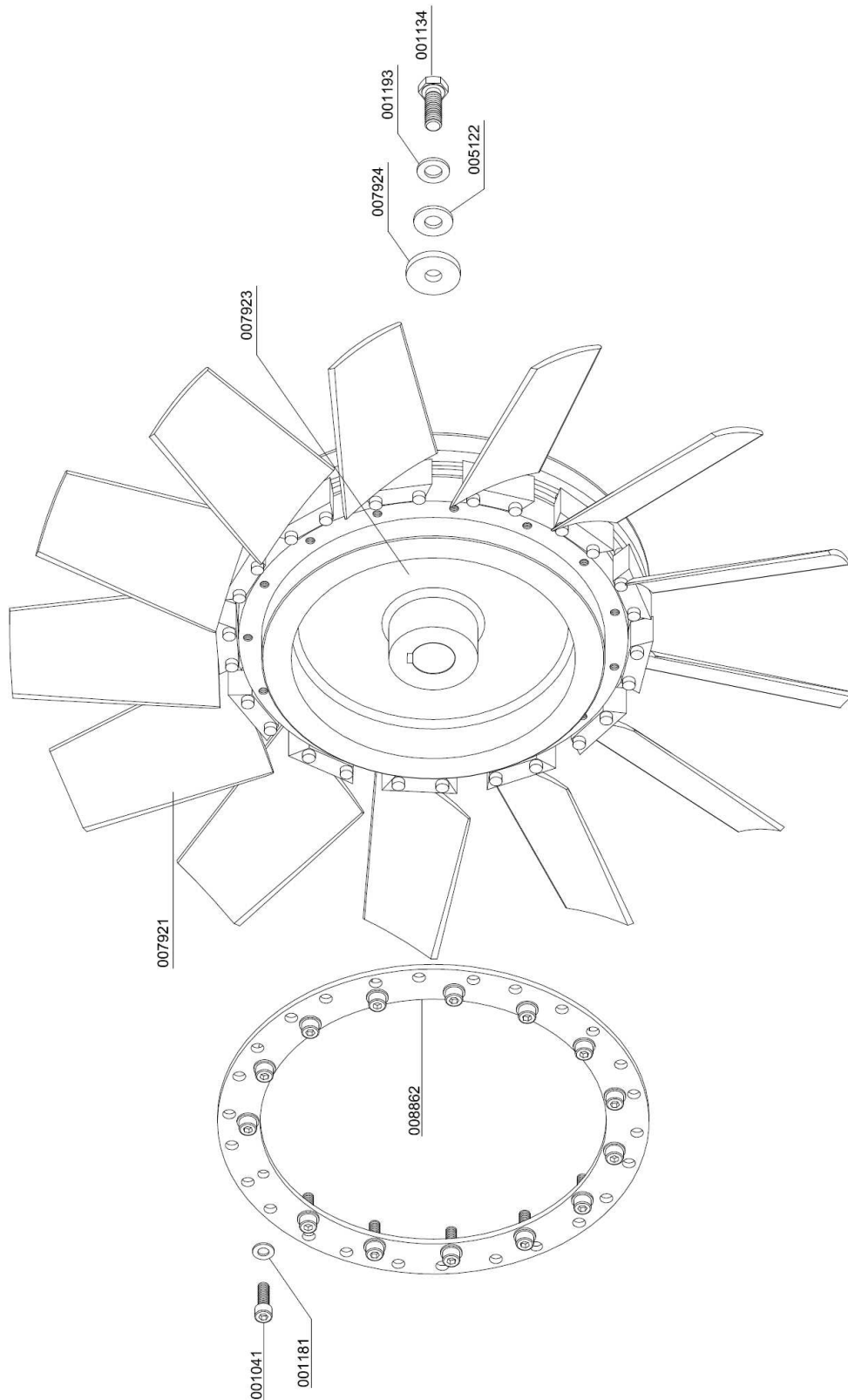

C



ERSATZTEILLISTE / SPARE PART LIST

Baugruppe: Wasserabscheider / Assembly: Water Separator

Best.-Nr. / Order No.	Benennung	Description
000227	Sicherheitsventil G3/8"	Safety Valve G3/8" 70 bar
000320	Gerade Verschraubung	Straight Connection
000391	U-Sit Ring	Seal Ring U-Sit
000811	Verschraubung	Elbow Connection WE3/8"/12L
000837	Verschlussstopfen	Plug
001159	Stopfmutter	Lock Nut M8
001181	U-Scheibe A8	Washer A8
001255	O-Ring	O-Ring
002123	Sinterfilter G3/8" AG, 1. + 2. Stufe	Sinterfilter G3/8" 1st+2nd St.
002128	Wasserabscheider, 1. und 2. Stufe	Water separa. 1st + 2nd Stage
002130	Halter für Sinterfilter G3/8"	Holder for Sinterfilter G3/8"
003077	Entwässerungsventil G1/4" AG, konisch	Drain valve G1/4" male
008482	Haltebügel für Wasserabweiser LW250	U-Clamp Water Separator

C

DETAILANSICHT / DETAILED VIEW

Baugruppe: Wasserabscheider / Assembly: Water Separator

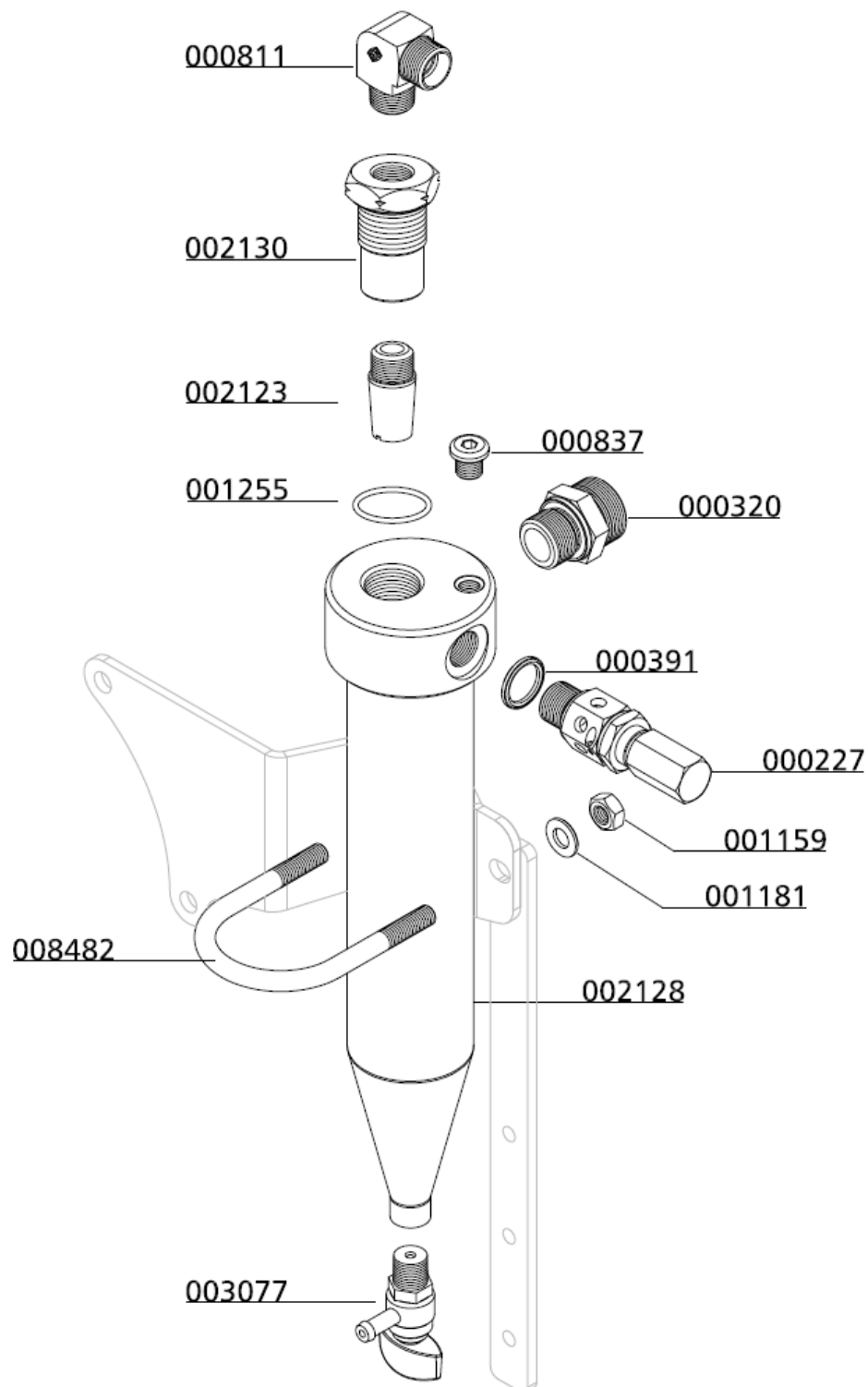

C



ERSATZTEILLISTE / SPARE PART LIST

Baugruppe: Ansaugfilter / Assembly: Intake Filter

Best.-Nr. / Order No.	Benennung	Description
000170	Ansaugfilterpatrone	Air Intake Filter Cartridge
000171	Ansaugfiltergehäuse inkl. Patrone, kompl	Int. Filter Housing c/w filter
000201	Einschraubadapter Ansaugfilter	Adapter Inlet Filter Housing

C

DETAILANSICHT / DETAILED VIEW

Baugruppe: Ansaugfilter / Assembly: Intake Filter

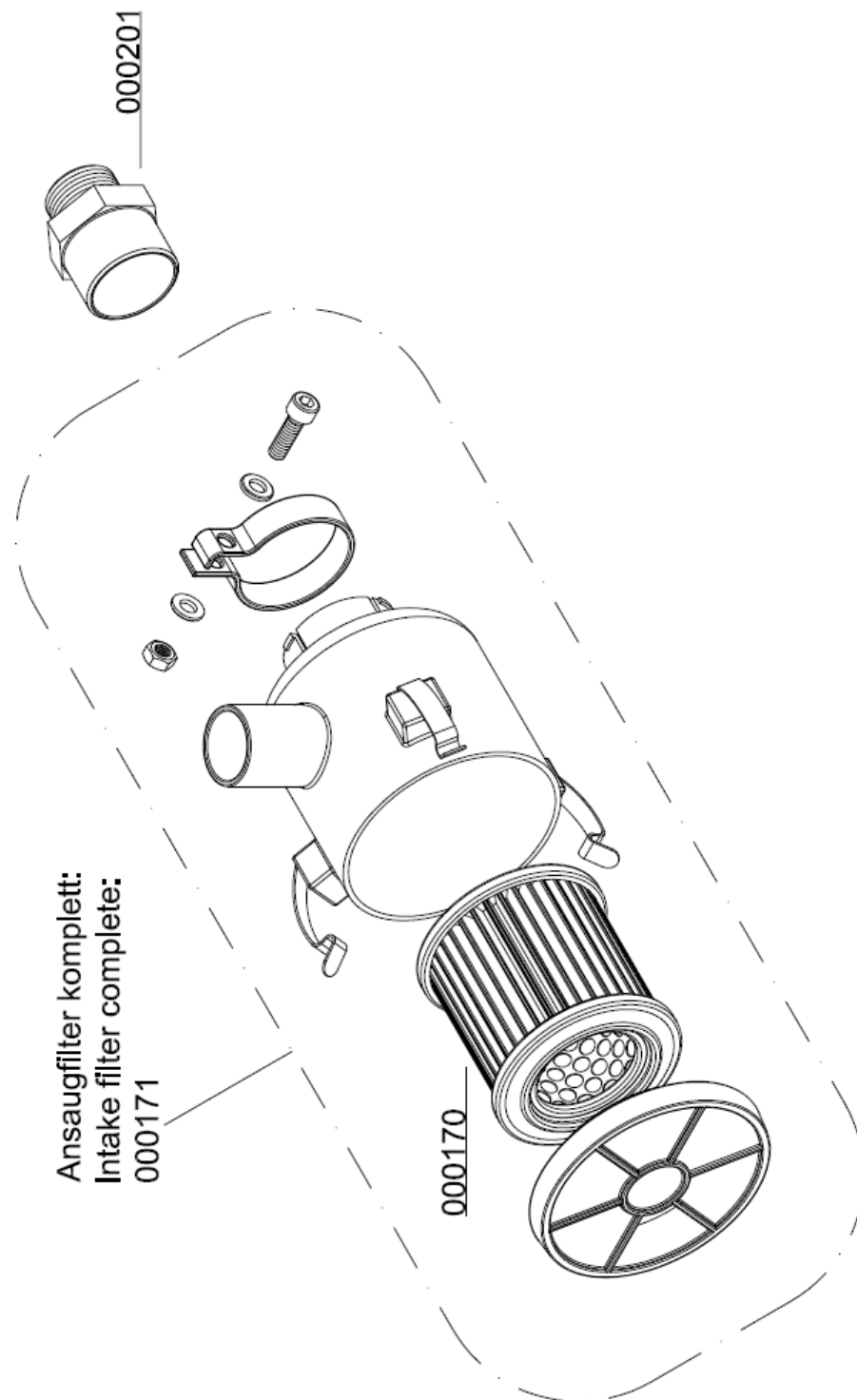

C



ERSATZTEILLISTE / SPARE PART LIST

Baugruppe: Ölablassschlauch / Assembly: Oil Drainage Tube

Best.-Nr. / Order No.	Benennung	Description
000817	Verschraubung	Connection
001005	Zylinderschraube M5x16mm DIN912	Allen Screw M5x16mm DIN912
002153	Ölablassschlauch inkl. Kugelhahn	Oil Drain Hose c/w Ball Valve
006964	Klemmhalter Ölablassschlauch	Clamp Oil Drain Hose

C

DETAILANSICHT / DETAILED VIEW

Baugruppe: Ölablassschlauch / Assembly: Oil Drainage Tube

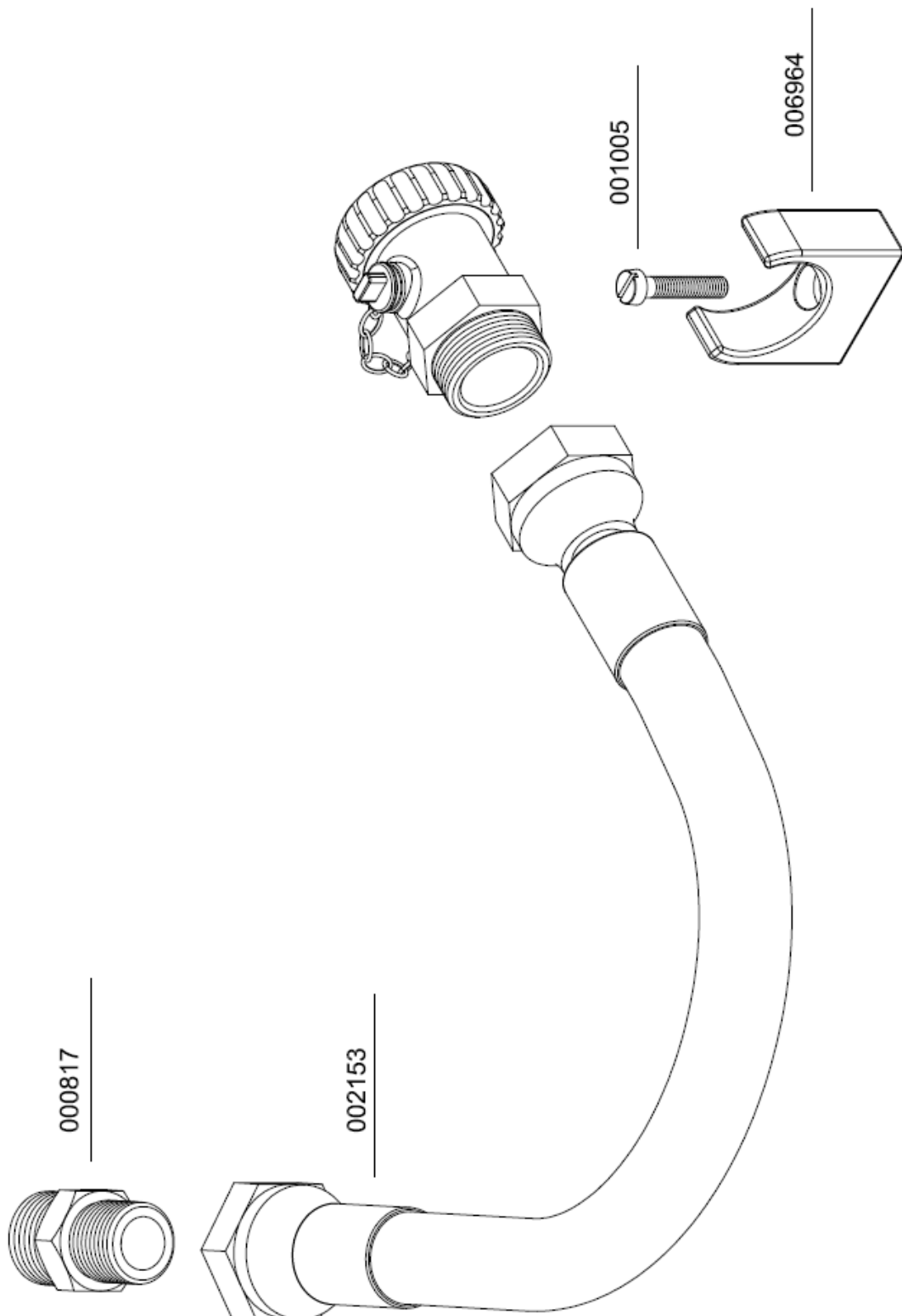

C



ERSATZTEILLISTE / SPARE PART LIST

Baugruppe: Ölpumpe / Assembly: Oil Pump

Best.-Nr. / Order No.	Benennung	Description
000204	Ölpumpe, kompl.	Oil Pump compl.
000208	Ölpumpenantriebsflansch	Drive Flange Oil Pump
000498	U-Scheibe A6	Washer A6
000737	Verschraubung	Connection
000761	Winkelverschraubung	Elbow Connection
000765	Schneidring 8 mm	Olive Seal 8 mm
000766	Mutter 08L	Nut 08L
000958	Gewindestift M8x16mm DIN914	Hexagon Socket Screw M8x16mm DIN914
001029	Zylinderschraube M6x20mm DIN912	Allen Bolt M6x20mm DIN912
002340	O-Ring Ölsaugadapter	O-Ring, oil pump flange
007900	O-Ring	O-Ring
008603	VA Rohr "Ölpumpe - Ölfilter"	Pipe
008608	VA Rohr "Block - Ölpumpe"	Pipe

C

DETAILANSICHT / DETAILED VIEW

Baugruppe: Ölpumpe / Assembly: Oil Pump

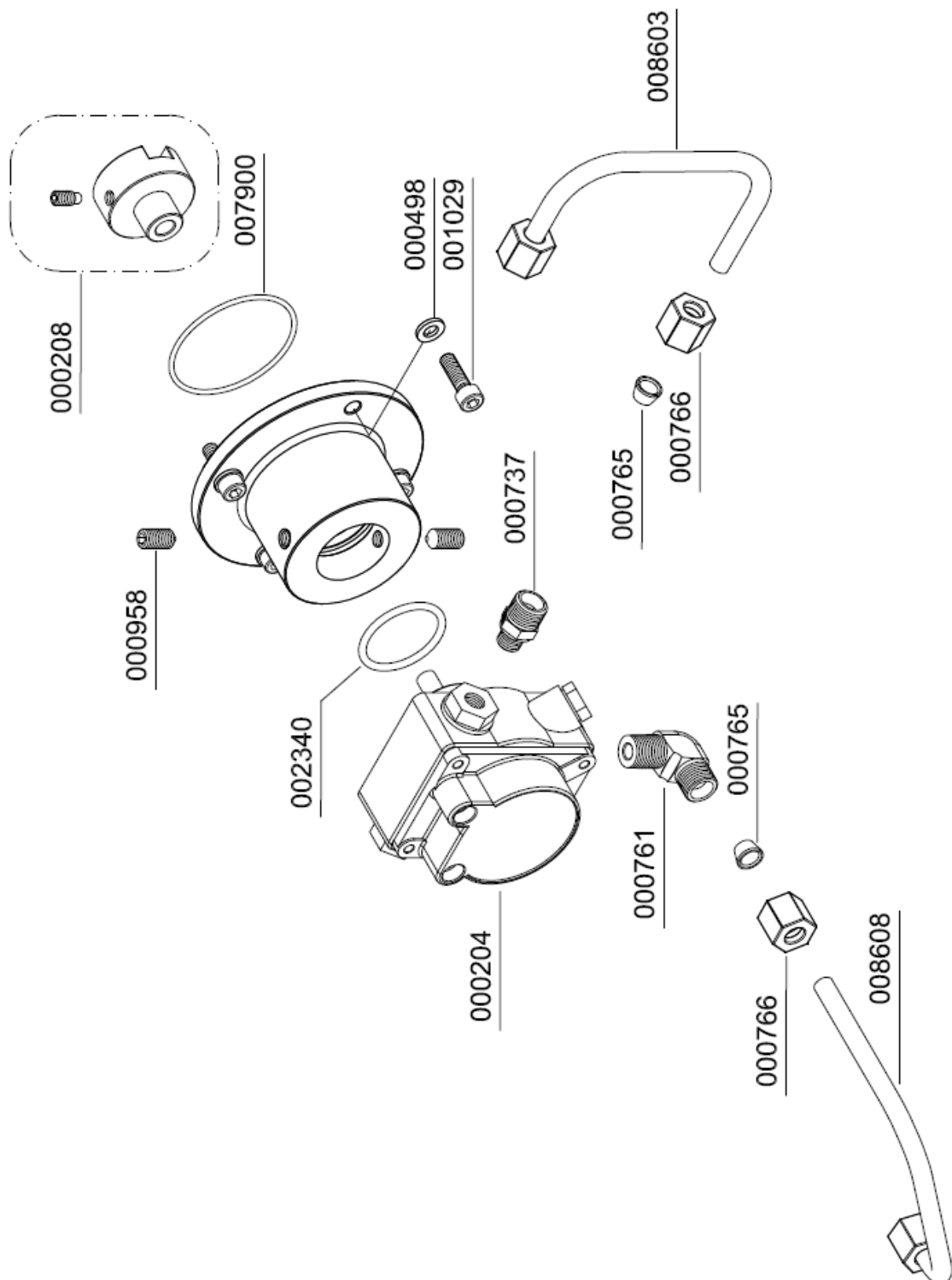

C



ERSATZTEILLISTE / SPARE PART LIST

Baugruppe: Endfiltergehäuse LW 300 D MC / Assembly: Final Filter Tower LW 300 D MC

Best.-Nr. / Order No.	Benennung	Description
000498	U-Scheibe A6	Washer A6
000506	Druckfeder	Spring
000508	USIT Ring	Gasket Ring U-Sit
000516	Nutring, Druckhalte-/Rückschlagventil	Seal Ring PMV
000517	Druckfeder	Coil Spring PMV
000518	Unterlegscheibe DIN 125, M5	Washer, M5, brass
000519	Dichtkappe, Druckhalte-Rückschlagventil	Plastic Seal Piston PMV
000712	Verschraubung	Connection w/o nut& olive seal
000738	Verschraubung	Connection
000764	Winkerverschraubung	Elbow Connection c/w fixed nut
000837	Verschlussstopfen	Plug
000941	Madenschraube	Worm Screw
001028	Zylinderschraube	Allen Bolt
001039	Zylinderschraube	Allen Bolt
001181	U-Scheibe A8	Washer A8
001459	Filterpatrone	Filter Cartridge
001716	Obere Verschlusschraube Filtergehäuse	Plug Filter Housing
001717	Filtersockel, (Filtergehäuse)	Base Filter Housing
001742	Druckstift , Ø5x40mm	Pressure Pin
001743	Einlassverschraubung	Inlet Connection
001744	Einstellschraube	Adjusting Bolt
001769	O-Ring, Filtergehäuse	O-Ring Filter Housing
001788	Federdruckstück	Spring Adapter
001806	Halteband Filtergehäuse - inkl. Gummi	Jubilee Clip Filter Housing
001819	O-Ring, Filterpatrone-Nippel	O-Ring, Filter cartrid. nipple
001825	O-Ring, Filterpatrone	O-Ring, filter cartridge
003006	O-Ring, Druckhalteventil	O-Ring, PMV
003077	Entwässerungsventil G1/4" AG, konisch	Drain Valve G1/4" male
008282	Druckbehälterrohr	Tube Filter Housing

C



ERSATZTEILLISTE / SPARE PART LIST

Baugruppe: Endfiltergehäuse LW 300 D MC / Assembly: Final Filter Tower LW 300 D MC

Best.-Nr. / Order No.	Benennung	Description
008307	Umrüstsatz	Conversion Kit
008347	Filter-Nippel mit Aufnahme 1,7L.	Filter Nipple 1.7ltr
008348	Düsenrohr Hochdruckfilter	Nozzle Tube
008889	Halter Druckbehälter	Holder Pressure Vessel

C

DETAILANSICHT / DETAILED VIEW

Baugruppe: Endfiltergehäuse LW 300 D MC / Assembly: Final Filter Tower LW 300 D MC

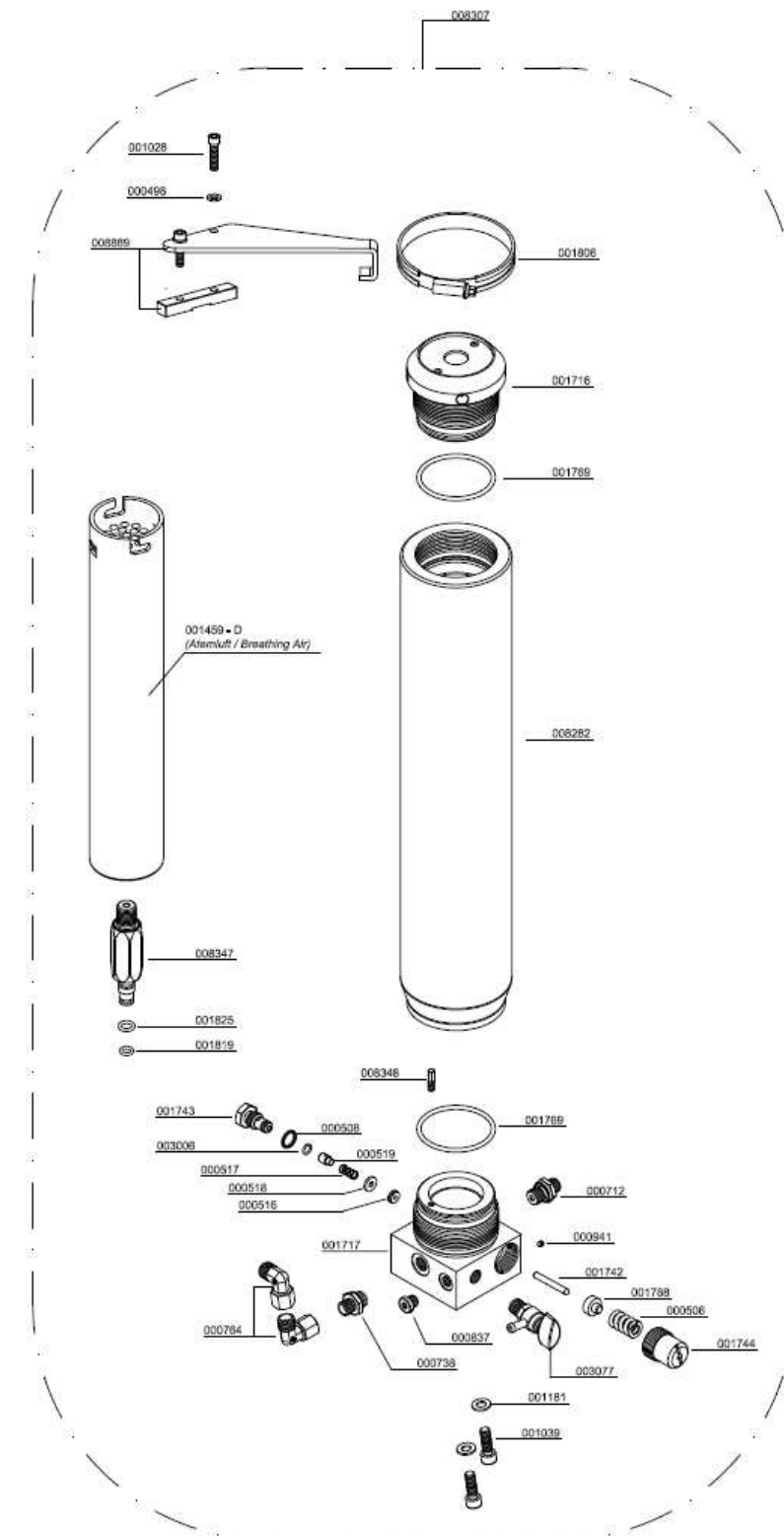

C



ERSATZTEILLISTE / SPARE PART LIST

Baugruppe: Sicherheitsventil / Assembly: Safety Valve

Best.-Nr. / Order No.	Benennung	Description
000553	Sicherheitsventil - Bauteilgeprüft	Safety Valve TÜV 225 bar
000554	Sicherheitsventil - Bauteilgeprüft	Safety Valve TÜV 250 bar
000555	Sicherheitsventil - Bauteilgeprüft	Safety Valve TÜV 300 bar
000556	Sicherheitsventil - Bauteilgeprüft	Safety Valve TÜV 330 bar
000557	Sicherheitsventil - Bauteilgeprüft	Safety Valve TÜV 350 bar
001058	Zylinderschraube M8x70mm DIN912	Allen Bolt M8x70mm DIN912
001244	O-Ring	O-Ring, flange safety valve
001814	Sicherheitsventil - Bauteilgeprüft	Safety Valve
001815	Sicherheitsventil - Bauteilgeprüft	Safety Valve
001816	Sicherheitsventil - Bauteilgeprüft	Safety Valve
001817	Sicherheitsventil - Bauteilgeprüft	Safety Valve

C

DETAILANSICHT / DETAILED VIEW

Baugruppe: Sicherheitsventil / Assembly: Safety Valve

Druck	SV-Ventil mit CE-Prüfung	SV-Ventil mit TÜV-Prüfung
225 bar	001814	000553
250 bar	001815	000554
285/300 bar	-----	000555
330 bar	001816	000556
350 bar	001817	000557

Sonder-Einstelldrücke auf Anfrage!/
Special relieve pressures are available on request!

Special relieve pressures are available on request!

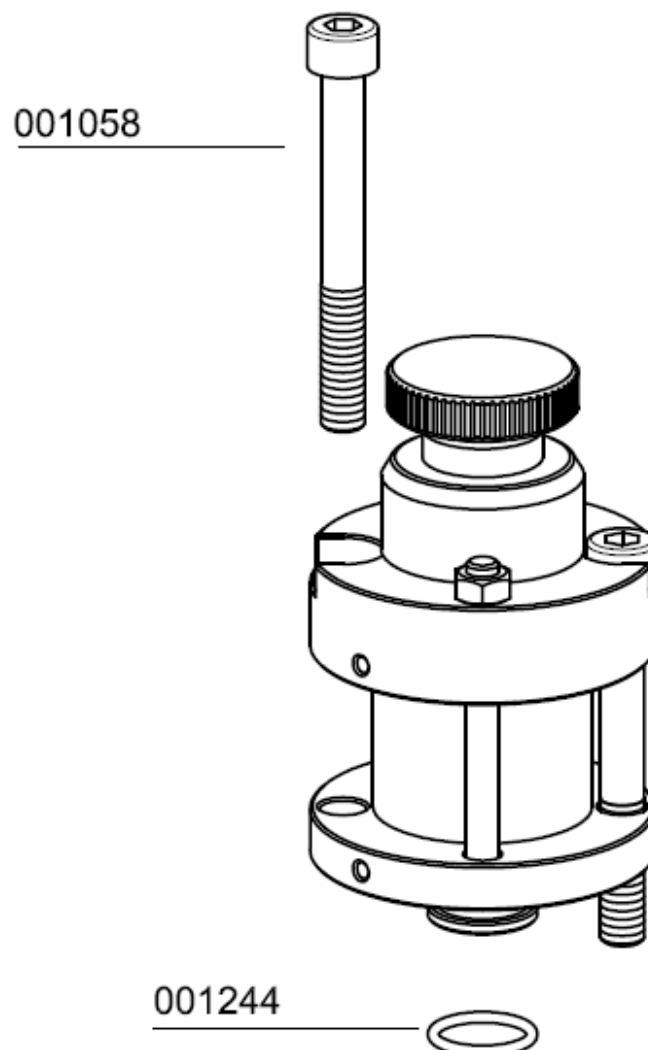



OPTIONS



Table of Contents

Additional Filling Hose	2
Wheel Set	5
Auto Shut Down.....	8
Automatic Condensation Drain.....	13
Switch Over Device 200+300bar.....	30
200+300bar Parallel Filling Pressure Operation.....	34
Oil Pressure Gauge	38
Oil Pressure Monitoring	41
Interstage Pressure Gauge	48
Cylinder Head Temperature Monitoring	53
Air Cooler Connection Kit.....	56



ADDITIONAL FILLING HOSE

C



ADDITIONAL FILLING HOSE

The additional hose with filling valve allows to fill two bottles simultaneously. The hose with filling valve is available in 200 and 300 bar version.

Please refer to Chapter A for all information about the filling process.

Best.-Nr. / Order No.	Benennung	Description
000738	Verschraubung	Connection
000783	Verschraubung	Straight Connection
000838	Verschlussstopfen	Plug
001022	Zylinderschraube	Allen Bolt
001152	Stopfmutter	Lock Nut M5
001176	U-Scheibe A5	Washer A5
008257	Verteilerblock 5xG1/4"	Distributor Block 5xG1/4"
008979	Manometerschlauch 1560 mm	Pressure Gauge Hose 1560 mm
008980	Hochdruckschlauch 1340mm	HP-Hose, Length: 1340 mm
008982	Verbindungsrohr, VA Ø8mm	Connecting Pipe, c/w nut+olive
008995	Winkelverschraubung	Elbow Connection

C

ADDITIONAL FILLING HOSE

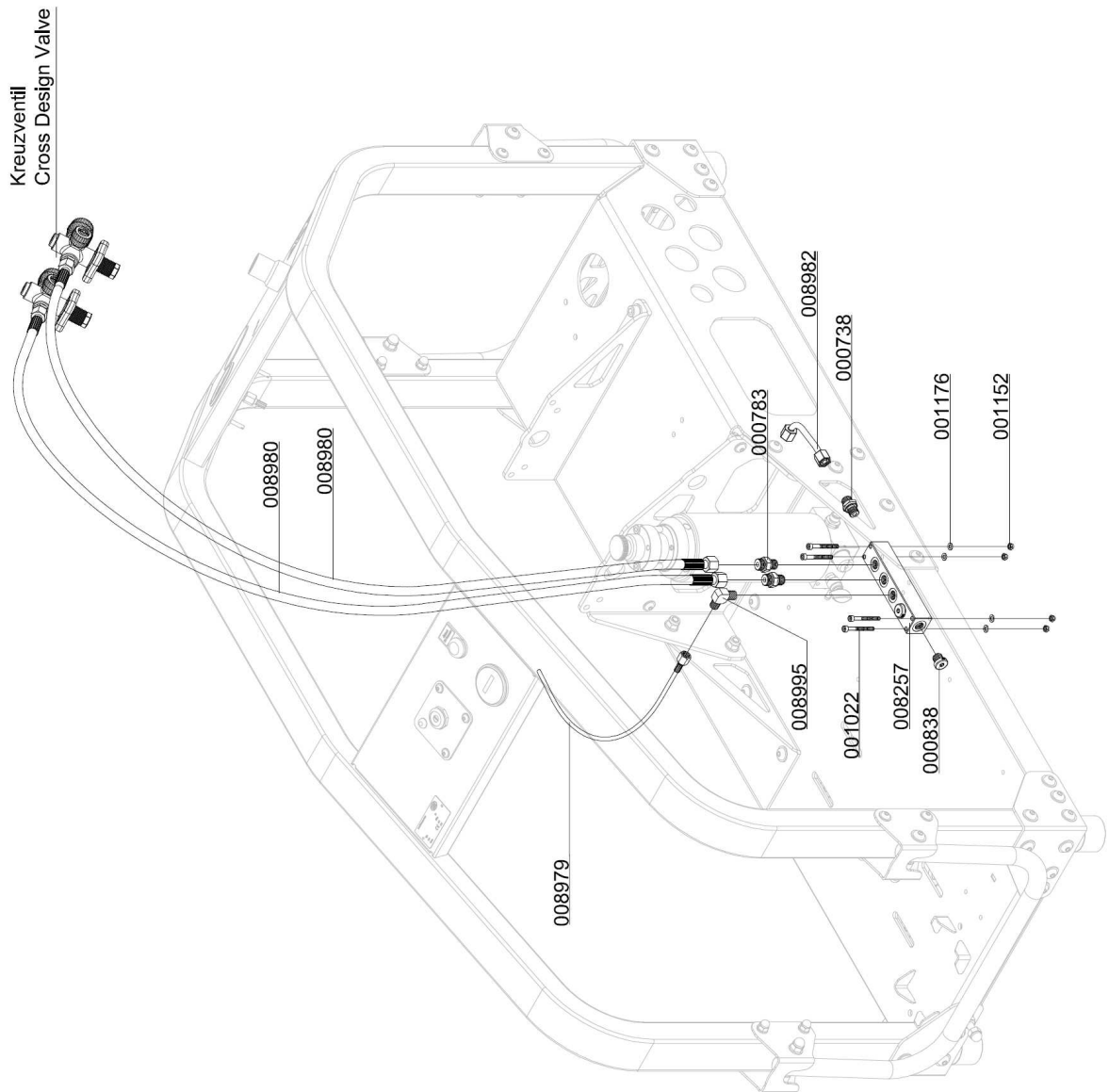



WHEEL SET

D



WHEEL SET

Best.-Nr. / Order No.	Benennung	Description
000964	Flachkopfzylinderschraube	Pan Head Bolt
001055	Zylinderschraube	Allen Bolt
001159	Stopfmutter	Lock Nut M8
001181	U-Scheibe A8	Washer A8
001186	U-Scheibe A10	Washer A10
001201	U-Scheibe A21	Washer A21
001676	Standfuß, Gummi	Rubber Foot
006788	Starlockkappen	Center Cap
006790	Stellring	Set Ring
006791	Luftrad	Wheel
009403	Federstecker Ø20mm	Spring Cotter Pin
009404	Halbachse für Radsatz	Half-axis
009405	Befestigungssockel Steckachse	Bounting Base
009406	Verbindungsstrebe Radsatz	Bracket
009407	Distanzstück für Gummifuß	Spacer

D

WHEEL SET

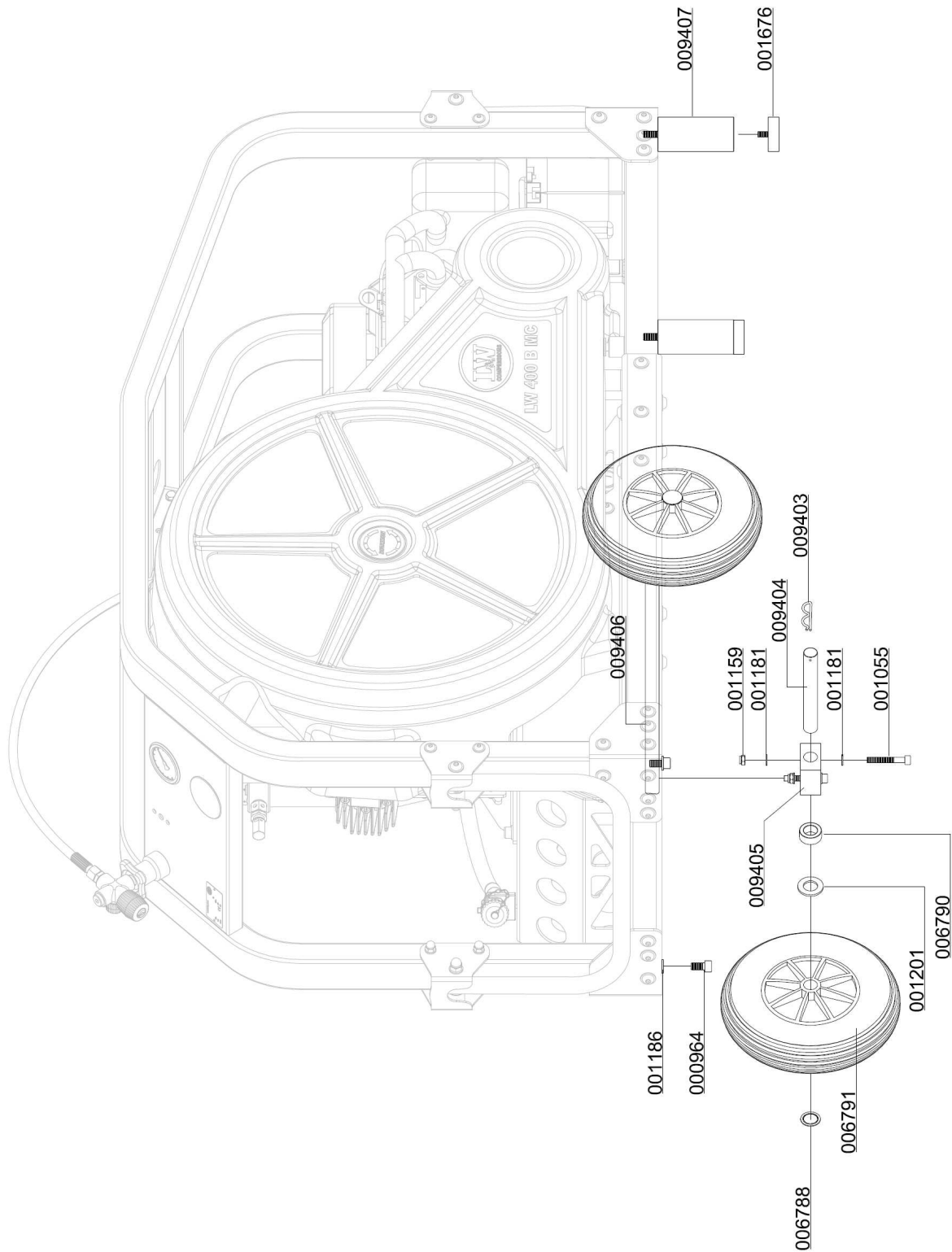

D



AUTO SHUT DOWN

D

AUTO SHUT DOWN

Final pressure switch

The pressure switch shuts off the compressor automatically when the selected final pressure is reached. The final pressure switch is already adjusted to the corresponding cut-out pressure.

The pressure can be adjusted with the upper adjusting screw as follows:

Increasing cut-out pressure:

Turn the adjusting screw clockwise

Reducing cut-out pressure:

Turn the adjusting screw anti-clockwise

Adjust the pressure switch in steps of a quarter turn.

Restart the compressor after every adjustment step to verify the actual cut-out pressure.

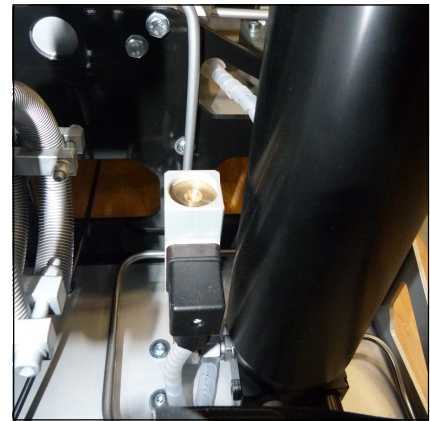

Final pressure switch

D



Note

Do not adjust the final pressure switch to the safety valve pressure. The final pressure switch has to be adjusted to min. 10 bar below the safety valve pressure. Otherwise, the safety valve can open during operation. This considerably reduces the life of the safety valve.

Example settings:

Safety valve	Max. Operating Pressure
225 bar	215 bar
250 bar	240 bar
330 bar	320 bar

AUTO SHUT DOWN

Pressure Switch

Best.-Nr. / Order No.	Benennung	Description
000203	Druckschalter, G1/4" IG, PV 50 - 350 bar	Pressure Switch 50-350 bar
000749	Verschraubung	Connection with fixed nut
000757	T-Verschraubung	T-Connection with fixed nut

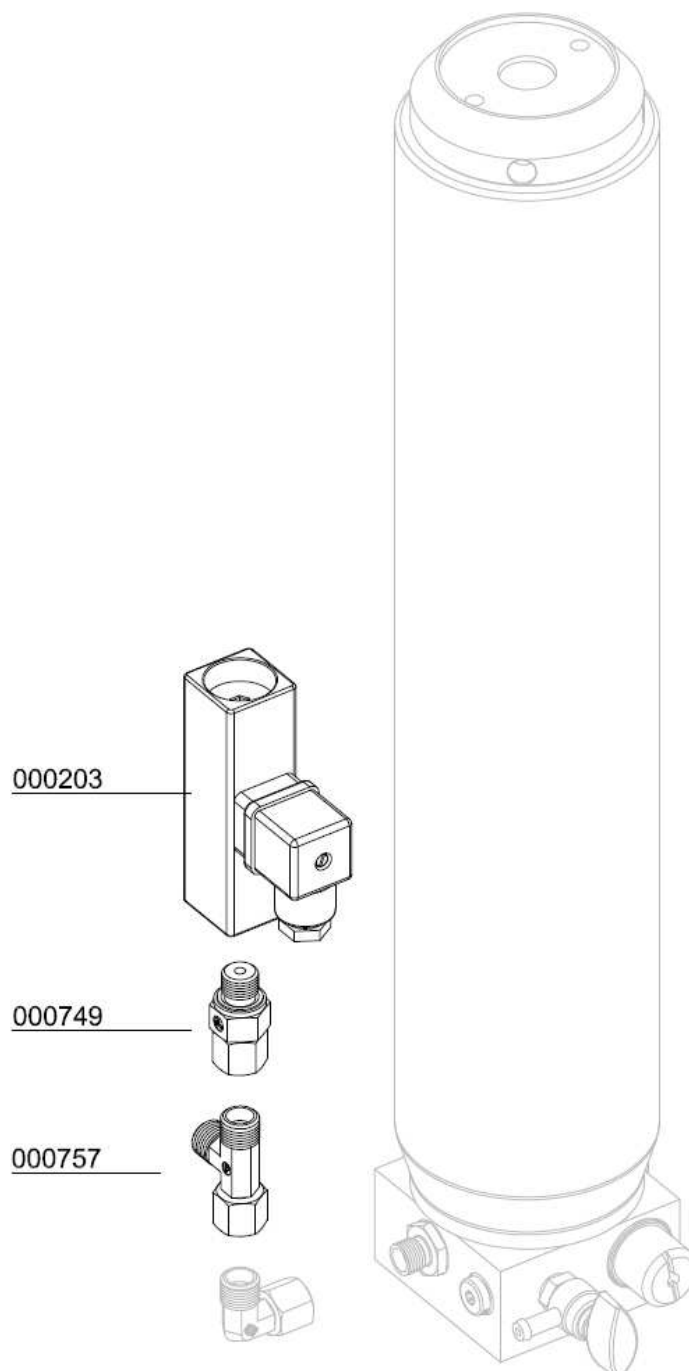



AUTO SHUT DOWN

Baugruppe: Elektroschaltkasten / Assembly: Electro Box

Best.-Nr. / Order No.	Benennung	Description
000498	U-Scheibe A6	Washer A6
001026	Zylinderschraube	Allen Bolt
001152	Stopfmutter M5	Lock Nut M5
001176	U-Scheibe A5	Washer A5
002090	Betriebsstundenzähler 10-80 V	Hour counter 10-80 V
004688	Befestigungsadapter Wahlschalter	Clamp adapter selector switch
004701	Leuchtmelder, flach, rot	Indicator light, red
004703	Einlegeschild "Öldruck Oil Pressure"	Label "Oil Pressure"
004704	LED-Element, Front, rot, Kontrollleuchte	LED, red, indicator light
005135	Schlauchschelle	Hose clamp
006090	Flachkopfschraube	Cross Cheese Head Screw
006859	Klemmrahmen (Schildträger)	Label holder
008778	Batterie	Battery 12V, 9 Ah
008971	Kabeldurchführung	Grommet
008972	Rittal Klemmgehäuse	Terminal Box
008974	Kabelschutzschlauch FPAS 28	Cable Protection Hose, 470mm
008975	Kabelverschraubung mit Mutter	Cable Glands with Nut
008976	Kabelverschraubung mit Mutter	Cable Glands with Nut
009234	Quertraverse	Transv. traverse (motor side)
009238	Schlüsselschalter	Keyswitch
009240	Halteblech Batterie	Bracket, Battery

D



AUTOMATIC CONDENSATION DRAIN

D

AUTOMATIC CONDENSATION DRAIN

Automatic condensation dump system



Note

The collected condensate can contain oil and has to be disposed according to regulations.

Automatic condensation dump system is an option for LW 320 - 400 E MC & B MC . Solenoids drain all condensate separators every 15 minutes.

To test the system, press the blue condensate test drain button on the operating panel.

Oil / water separators

Condensate is separated after 2nd and 3rd stage of compression. All separators are equipped with electronic timer controlled solenoid coils. The timer is located in the switch box and activates the dump valves about every 15 minutes.

To release the complete condensate through the black plastic hoses, we recommend using an 10 l container at least.

The drain noise can be kept to a minimum by using a silencer.

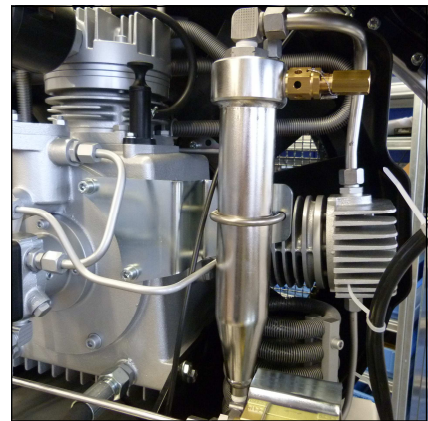

Oil / water separators 2nd stage

Maintenance intervals

We recommend to clean oil and water separators every 500 operating hours or at least once a year, to check for corrosion damage and to replace o-rings if necessary.

All oil / water separators have an integrated sinter filter which has to be replaced every 1,000 operating hours.

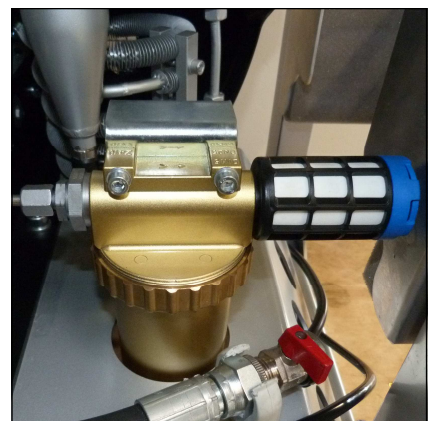

Oil / water separators final stage

AUTOMATIC CONDENSATION DRAIN

Oil / water separators final stage - maintenance



Note

Clean all parts thoroughly before assembly.

Change/clean oil / water separators final stage as follows:

- Loosen pipe connections and mounting screws.
- Remove oil / water separators.
- Open ring nut and remove separator top (Fig. 1).
- Loosen nut at the separator top.
- Change sinter filter (Fig. 2).
- Reassemble all parts and tighten nut.
- Change o-ring, previously grease new o-ring (Fig. 3).
- Place separator top and tighten ring nut manually.
- Replace silencer.
- Mount oil / water separators.
- Tighten pipe connections and mounting screws.

The oil / water separator maintenance is now completed.

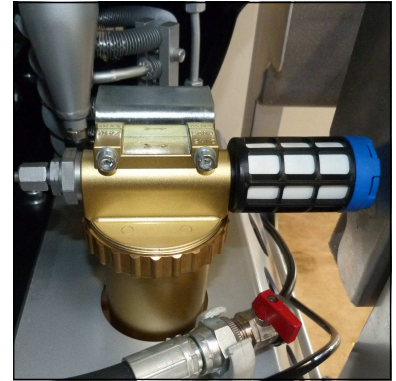

Oil / water separators final stage



Fig. 1 - Loosen ring nut

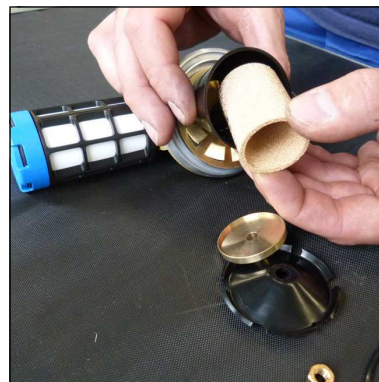

Fig. 2 - Change sinter filter

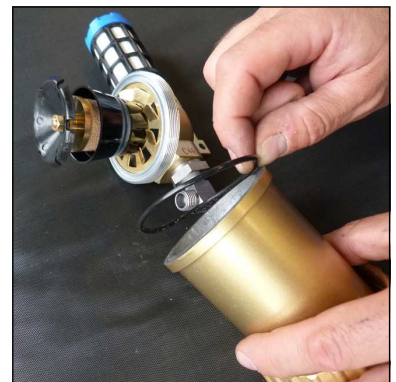

Fig. 3 - Change o-ring

AUTOMATIC CONDENSATION DRAIN

Pneumatic condensate valve - maintenance



Note

Clean all parts thoroughly before assembly.

Pneumatic condensate valve change as follows:

- Loosen pipe connections and mounting screws.
- Remove pneumatic condensate valve.
- Loosen connection (Fig. 2).
- Change sinter filter (Fig. 3).
- Tighten horizontal screw.
- Mount pneumatic condensate valve.
- Tighten pipe connections and mounting screws.

Pneumatic condensate valve maintenance is now completed.

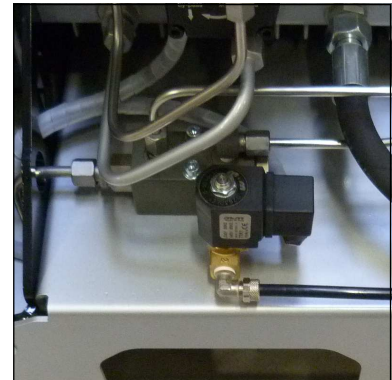

Pneumatic Condensate Valve

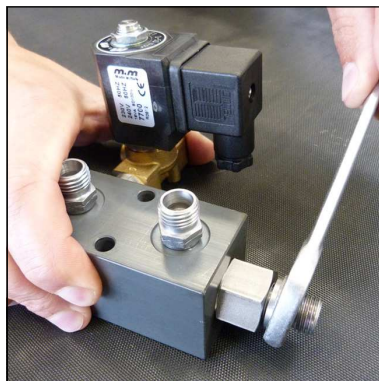

Fig. 2 - Loosen connection

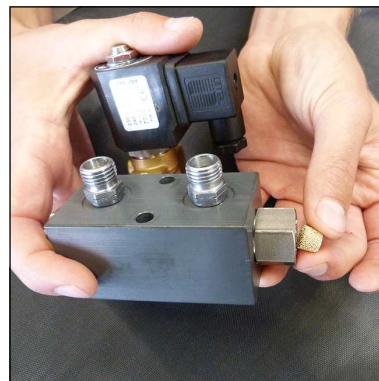

Fig. 3 - Change sinter filter



AUTOMATIC CONDENSATION DRAIN

Overall View: Automatic Condensation Drain

Spare Part List

Best.-Nr. / Order No.	Benennung	Description
003067	Kondensatschlauch 8x1 mm	Condensate hose 8x1mm Polyamid
008601	VA Rohr "Kondensatautom.- Ölabscheider"	Pipe
008602	VA Rohr "Wasserabs 2.S.- Kondensatautom"	Pipe
008609	VA Rohr "HD Filter - Kondensatautomatik"	Pipe

D

AUTOMATIC CONDENSATION DRAIN

Overall View: Automatic Condensation Drain

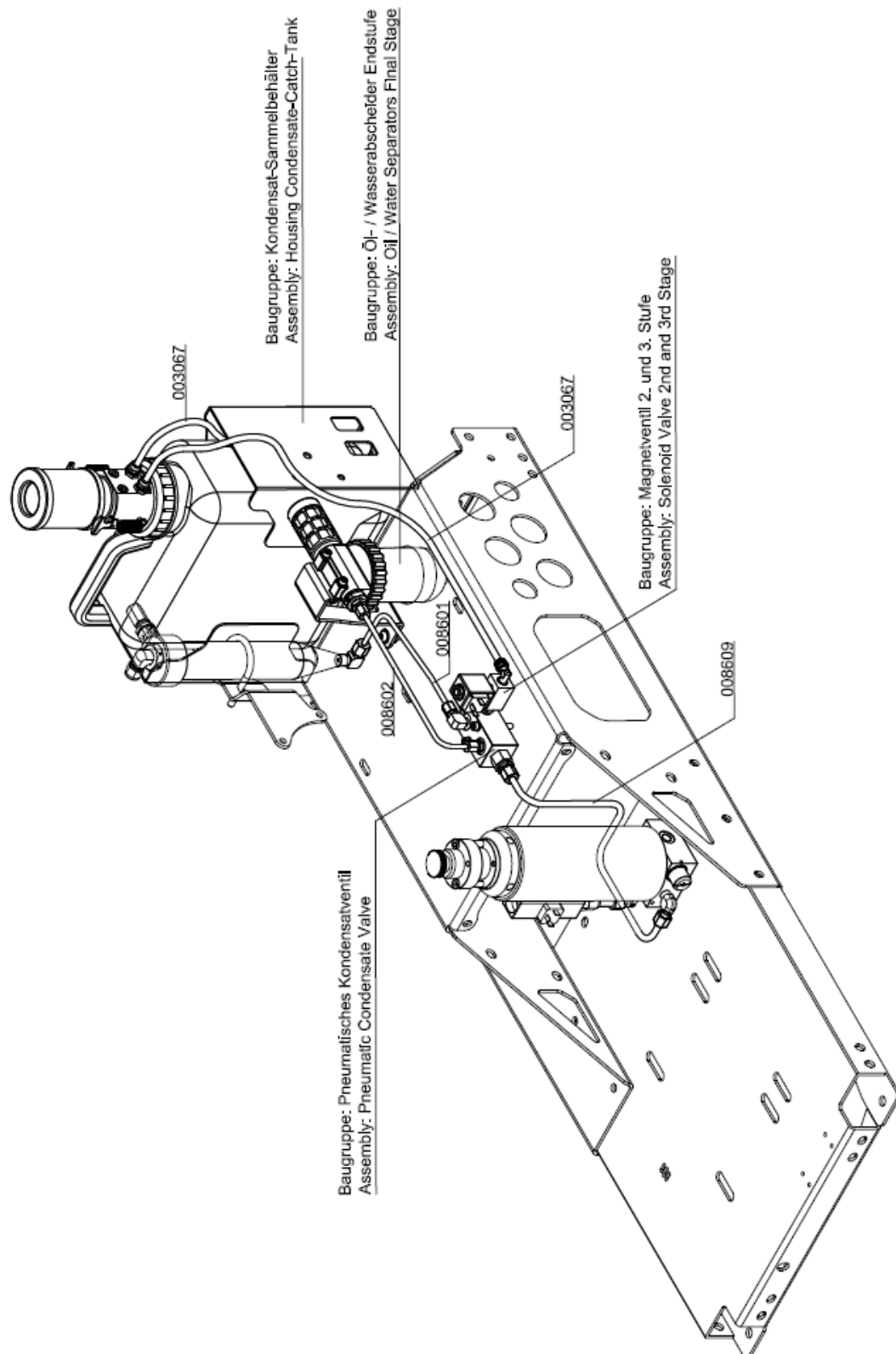

D



AUTOMATIC CONDENSATION DRAIN

Assembly: Pneumatic Condensate Valve

Spare Part List

Best.-Nr. / Order No.	Benennung	Description
000188	Sinterfilter, pneum. Kondensatventil	Sintered Filter
000191	Steuerkolben, pneum. Kondensatventil	Piston
000196	Düsenschraube, pneum. Kondensatventil	Inlet Jet Screw
000197	Stopfen, pneum. Kondensatventil	Plug
000198	Gehäuse, pneum. Kondensatventil	Body PCV
000498	U-Scheibe A6	Washer A6
000499	Zylinderschraube M6x55mm DIN912	Allen Bolt M6x55mm DIN912
000710	Verschraubung	Connection w/o nut& olive seal
000721	Verschraubung	Connection
000738	Verschraubung	Connection
001156	Stopfmutter M6	Lock Nut M6

D

AUTOMATIC CONDENSATION DRAIN

Assembly: Pneumatic Condensate Valve

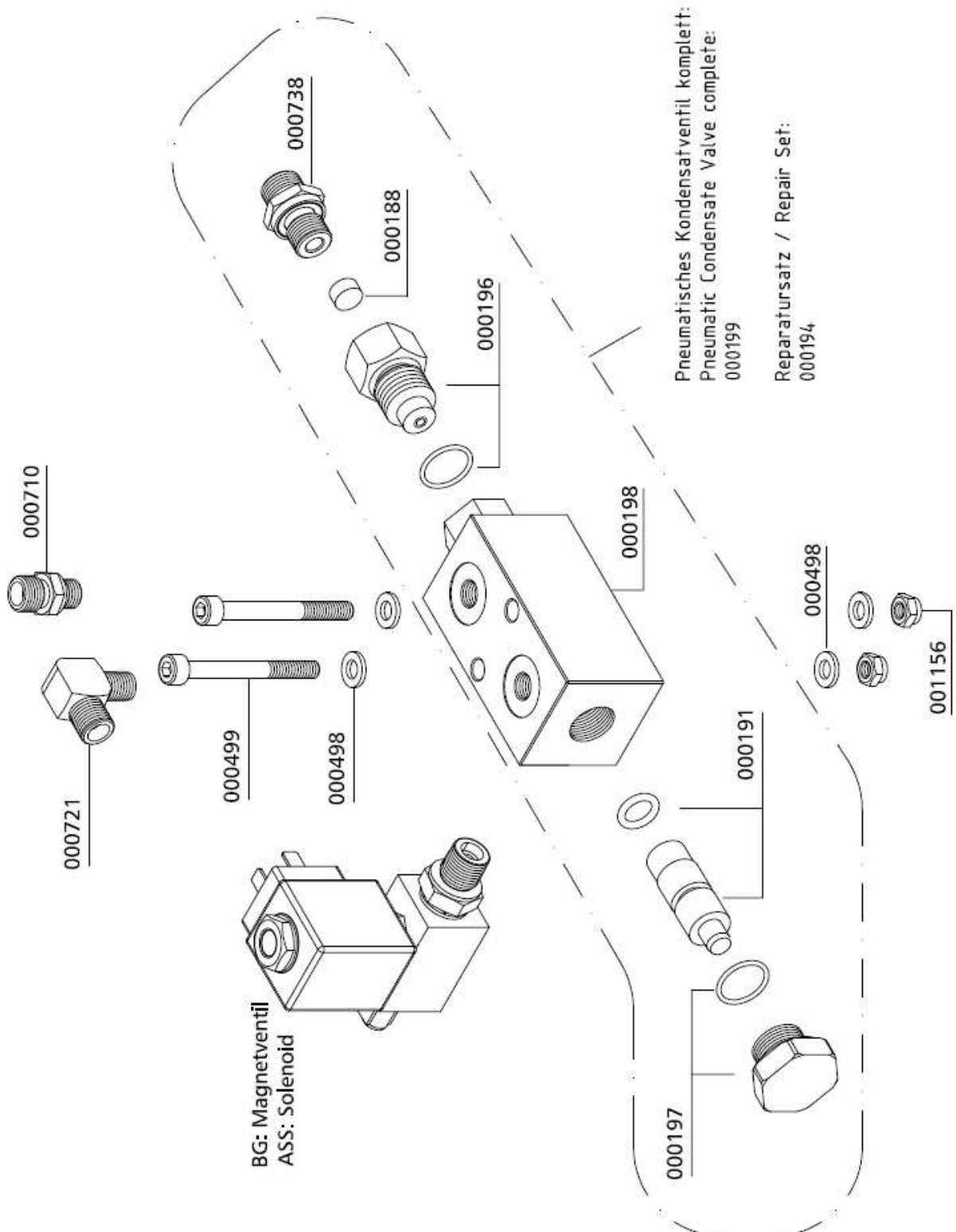

D

AUTOMATIC CONDENSATION DRAIN

Assembly: Solenoid

Spare Part List

Best.-Nr. / Order No.	Benennung	Description
000603	Magnetspule NC 12V DC 80 bar	Solenoid Coil NC 12V DC 80 bar
000892	Doppelnippel	Double Nipple
001546	Aludichtring für Magnetventile G1/4"	Alloy Seal Ring for G1/4" male
004002	Magnetventil 40/80 bar	Solenoid Valve, Housing: Brass
005855	Winkeleinschraubverschraubung 8 mm	Elbow Hose Connection 8 mm

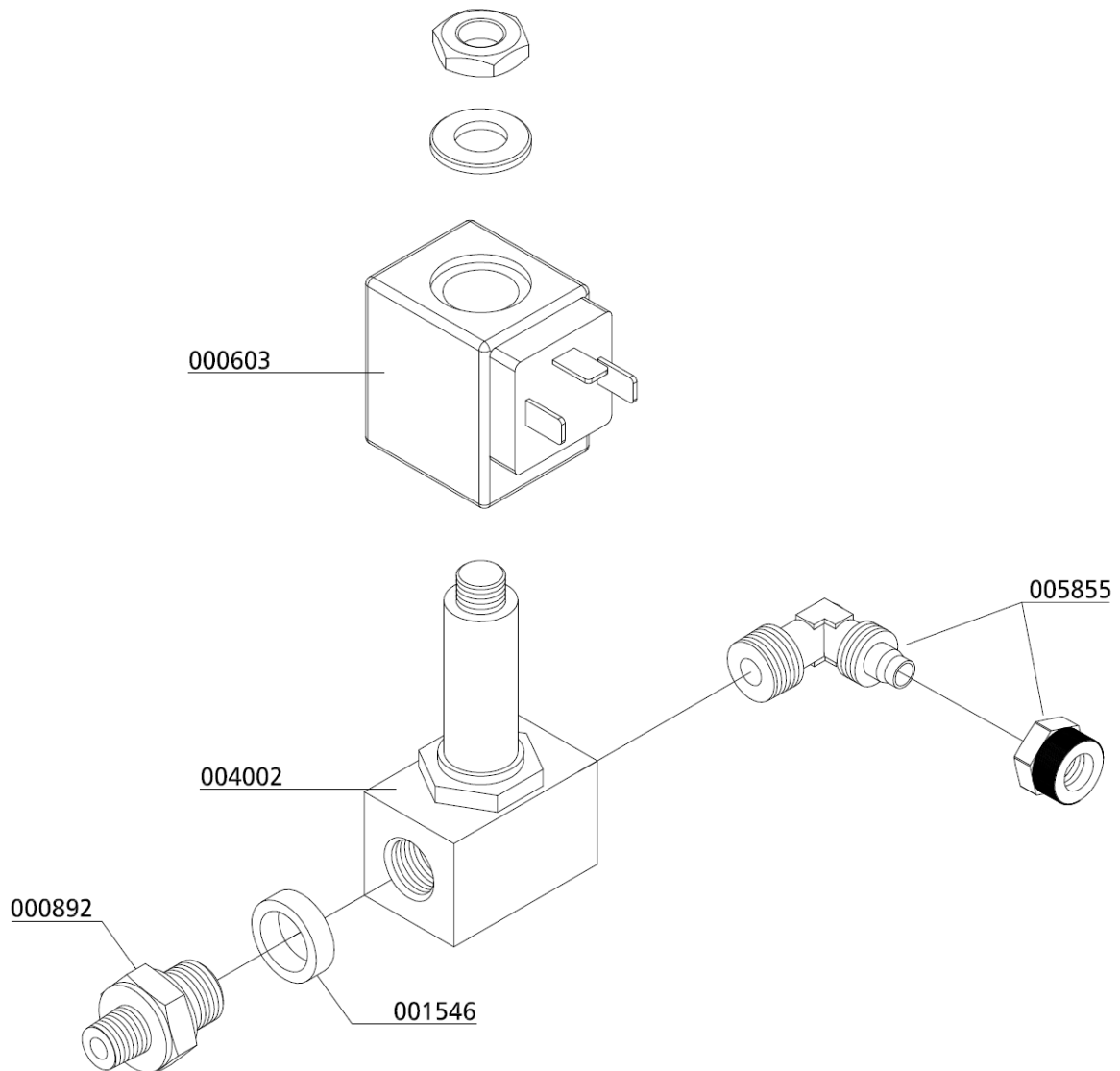



AUTOMATIC CONDENSATION DRAIN

Assembly: Oil / Water Separators Final Stage

Spare Part List

Best.-Nr. / Order No.	Benennung	Description
000175	Abweiser Öl-/ Wasserabscheider	Deflector Oil/Water Separator
000178	Schalldämpfer G1/2"	Silencer G1/2"
000183	Wasserabweiser	Filter Protecor
000184	Sinterfilter Wasserabscheider	Siltered Filter, Oil Filter
000185	Haltehalter	Plate, water separator
000186	Drallscheibe, z.B. 1. Stufe	Twist Disk, 1st. Stage
000498	U-Scheibe A6	Washer A6
000710	Verschraubung	Connection w/o nut& olive seal
000921	Reduzierung	Reducer
001156	Stopfmutter M6	Lock Nut M6
001159	Stopfmutter M8	Lock Nut M8
001181	U-Scheibe A8	Washer A8
001294	O-Ring Wasserabscheider, Endabscheider	O-Ring, water separator
001431	Klemmring Wasserabscheider	Lock Ring Water Separator
002466	Kondensatbehälter für Abscheider	Condensate bowl,
002563	Wasserabscheider Oberteil	Water Separator, Top
005856	Winkeleinschraubverschraubung 8 mm	Elbow Hose Connection 8 mm
007972	Halterung Endabscheider	Bracket final separator
008419	Linsenflanschschraube M8x25	lens head screw
008822	Kondensatabscheider Endstufe	Water Separator

D

AUTOMATIC CONDENSATION DRAIN

Assembly: Oil / Water Separators Final Stage

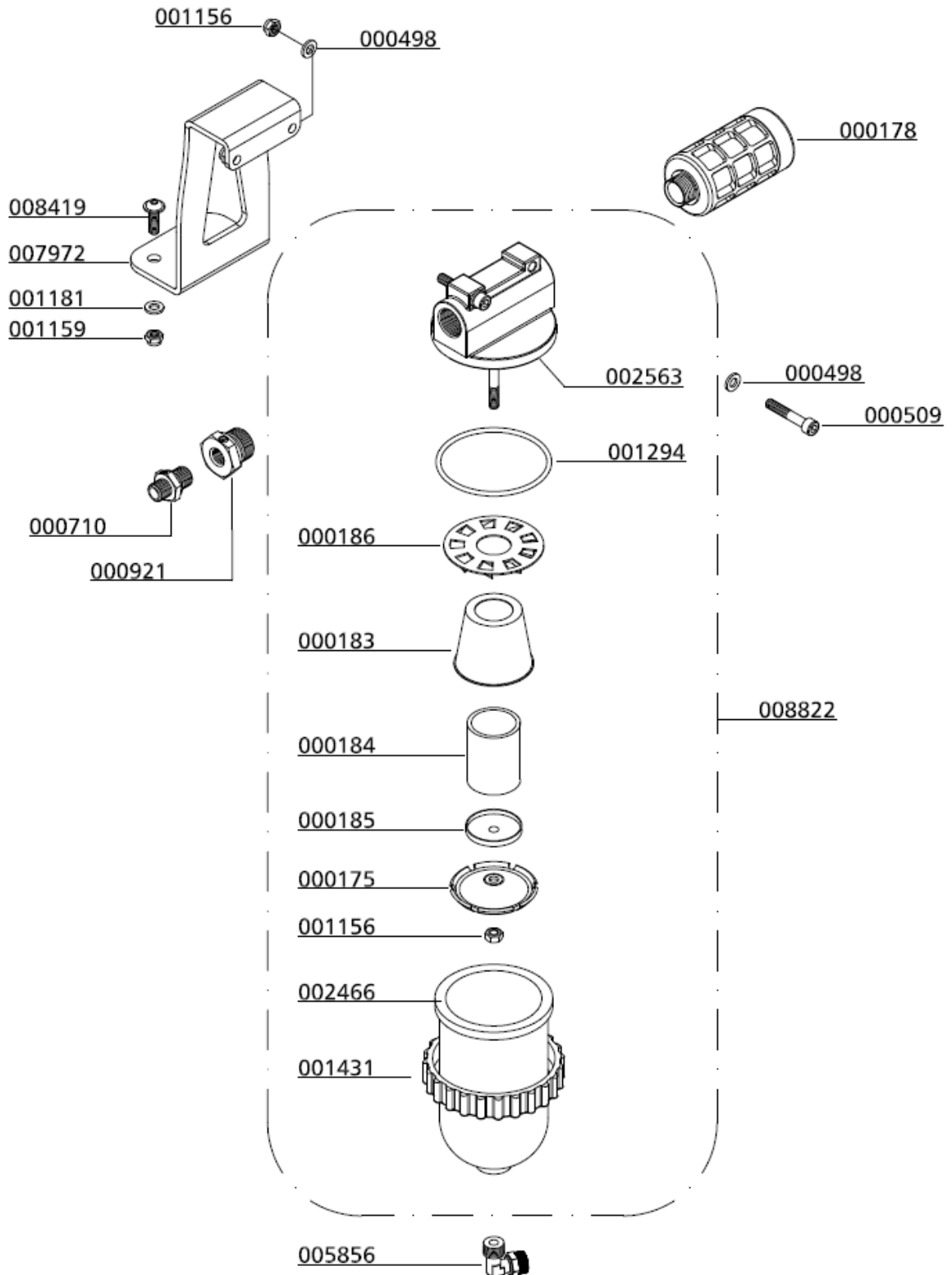

D



AUTOMATIC CONDENSATION DRAIN

Assembly: Housing Condensate-Catch-Tank

Spare Part List

Best.-Nr. / Order No.	Benennung	Description
002152	O-Ring	O-Ring
005857	Gerade Einschraubverschraubung 8 mm	Straight Hose Connection 8 mm
006356	Kondensatbehälter 10 Liter	Condensate Catch Tank 10 Litre
006379	Zugfeder Kondensatfilterpatrone	Spring Condensate Filter Cartr
006460	Federspannblech Kondensatbehälter	Spring Clamping Plate CCT
008495	Filter Kondensatbehälter	Filter Condensate Catch Tank
008655	Linsenflanschschraube M6x12mm	Lens Head Screw M6x12mm
008680	Halteblech 10-Liter Kondensatbehälter	Holder Condensate Catch Tank 10 Litre
008831	Verschlussstopfen	Plug

D

AUTOMATIC CONDENSATION DRAIN

Assembly: Housing Condensate-Catch-Tank

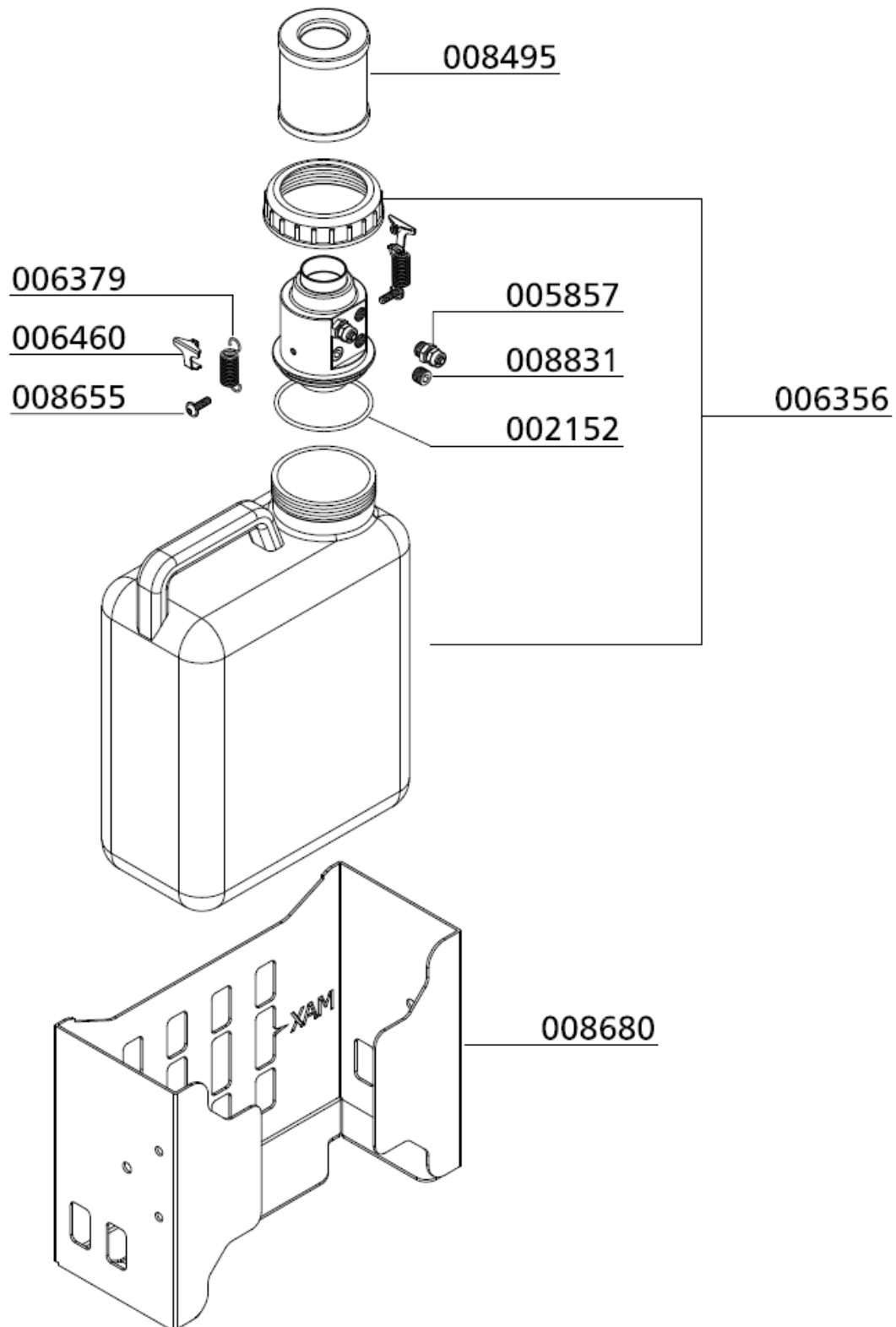

D



AUTOMATIC CONDENSATION DRAIN

Assembly: Final Filter Tower

Spare Part List

Best.-Nr. / Order No.	Benennung	Description
000203	Druckschalter, G1/4" IG, PV 50 - 350 bar	Pressure Switch 50-350 bar
000749	Verschraubung	Connection with fixed nut
000757	T-Verschraubung	T-Connection with fixed nut
000761	Winkelverschraubung	Elbow Connection
000764	Verschraubung	Connection with fixed nut

D

AUTOMATIC CONDENSATION DRAIN

Assembly: Final Filter Tower

Automatic Condensation Drain

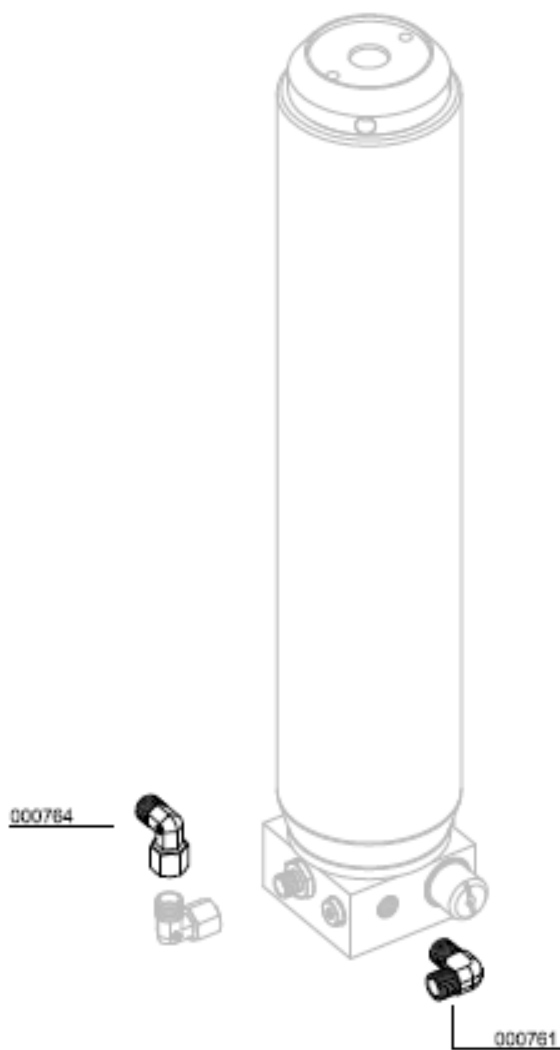

Automatic Condensation Drain
&
Auto Shut Down

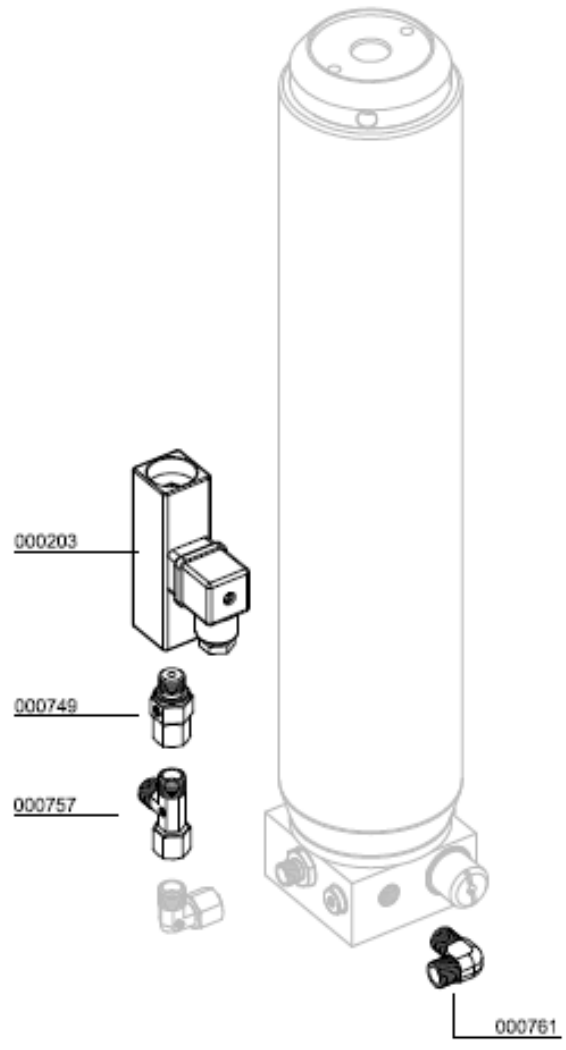

D



AUTOMATIC CONDENSATION DRAIN

Baugruppe: Elektroschaltkasten / Assembly: Electro Box

Best.-Nr. / Order No.	Benennung	Description
000498	U-Scheibe A6	Washer A6
001026	Zylinderschraube	Allen Bolt
001152	Stopfmutter M5	Lock Nut M5
001176	U-Scheibe A5	Washer A5
002090	Betriebsstundenzähler 10-80 V	Hour counter 10-80 V
004688	Befestigungsadapter Wahlschalter	Clamp adapter selector switch
004701	Leuchtmelder, flach, rot	Indicator light, red
004703	Einlegeschild "Öldruck Oil Pressure"	Label "Oil Pressure"
004704	LED-Element, Front, rot, Kontrollleuchte	LED, red, indicator light
005135	Schlauchschelle	Hose clamp
006090	Flachkopfschraube	Cross Cheese Head Screw
006859	Klemmrahmen (Schildträger)	Label holder
008778	Batterie	Battery 12V, 9 Ah
008971	Kabeldurchführung	Grommet
008972	Rittal Klemmgehäuse	Terminal Box
008974	Kabelschutzschlauch FPAS 28	Cable Protection Hose, 470mm
008975	Kabelverschraubung mit Mutter	Cable Glands with Nut
008976	Kabelverschraubung mit Mutter	Cable Glands with Nut
009234	Quertraverse	Transv. traverse (motor side)
009238	Schlüsselschalter	Keyswitch
009240	Halteblech Batterie	Bracket, Battery

D

AUTOMATIC CONDENSATION DRAIN

Baugruppe: Elektroschaltkasten / Assembly: Electro Box

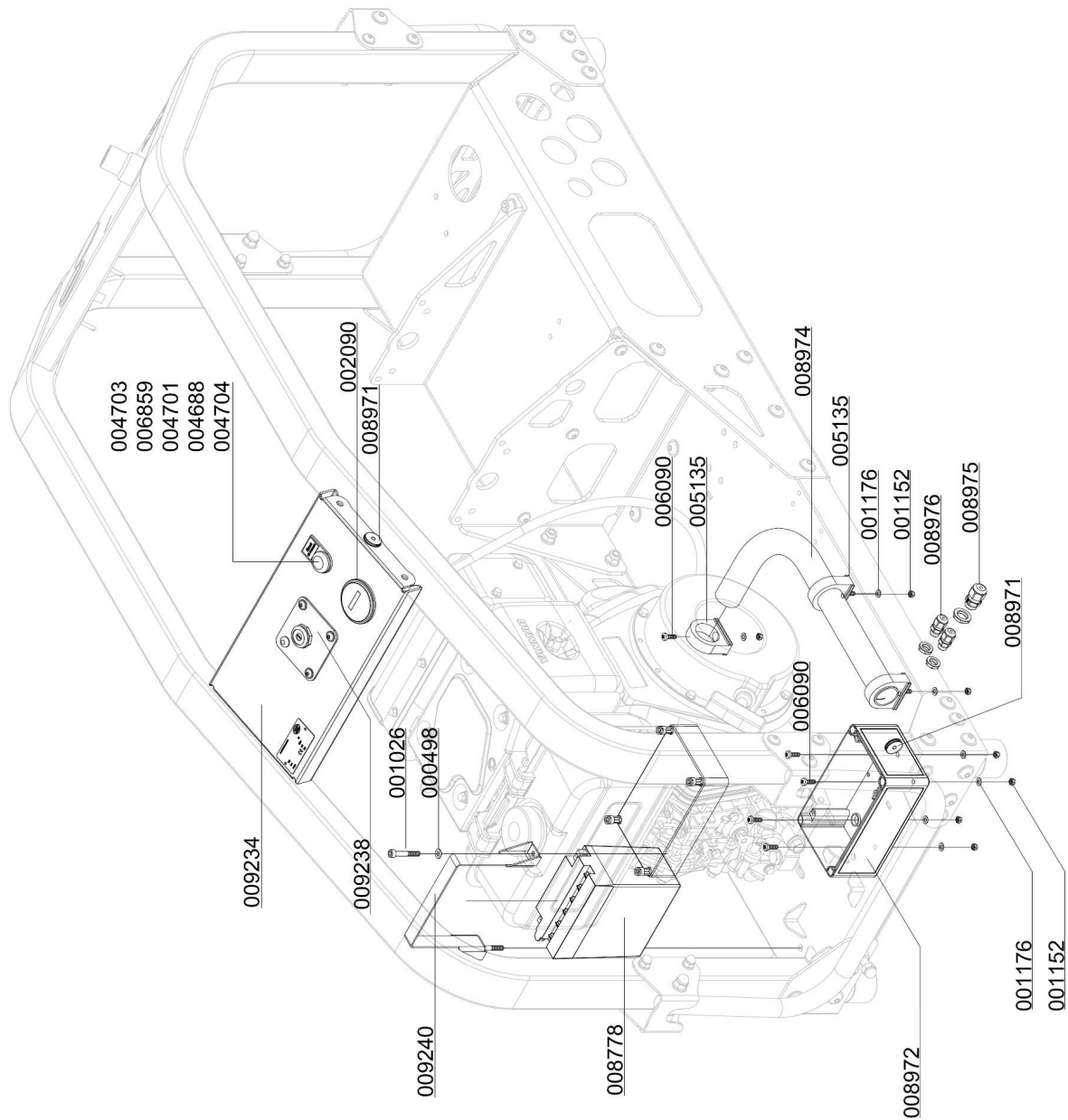

D



SWITCH OVER DEVICE 200/300 BAR

C

SWITCH OVER DEVICE 200/300BAR

Operation:

300 bar

The pressure selector spindle (1) should be screwed fully in clockwise.

200 bar

The pressure selector spindle (1) should be screwed fully out anti clockwise.



Switch over Device



ATTENTION

Operate 200/300bar pressure selector spindle (1) only if filterhousing has been vented by using the drainage valve (2).

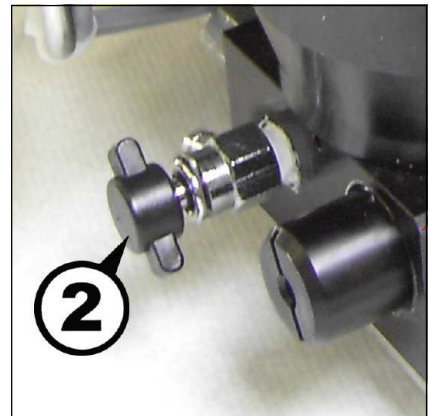

Drain Valve at Final Filter Tower



SWITCH OVER DEVICE 200/300BAR

Switch Over Device 200/300bar

Best.-Nr. / Order No.	Benennung	Description
000391	U-Sit Ring,	Seal Ring U-Sit
000796	Verschraubung	Elbow Connection
001001	Zylinderschraube	Allen Bolt
001055	Zylinderschraube	Allen Bolt
001156	Stopfmutter	Lock Nut M6
001244	O-Ring	O-Ring, flange safety valve
001770	O-Ring, Düsen-schraube	O-Ring Inlet Jet
001808	Sicherheitsventil 3. Stufe 330bar	Safety Valve 3rd Stage 330bar
002135	Sicherheitsventil 3. Stufe 225bar	Safety Valve 3rd Stage 225bar
002136	Sicherheitsventil 3. Stufe 250bar	Safety Valve 3rd Stage 250bar
002354	O-Ring	O-Ring
005173	Spindel Druckumschaltung	Spindle, switch over device
005174	Dichtkegel Druckumschaltung 200/300 bar	Conical nipple,switch o.device
006304	Umschaltventilkörper	Housing
006305	Hohlschraube	Banjo Bolt
006306	Sterngriff	Star Shaped Grip
006307	Verbindungs-nippel	Nozzle

C

SWITCH OVER DEVICE 200/300BAR

Switch Over Device 200/300bar

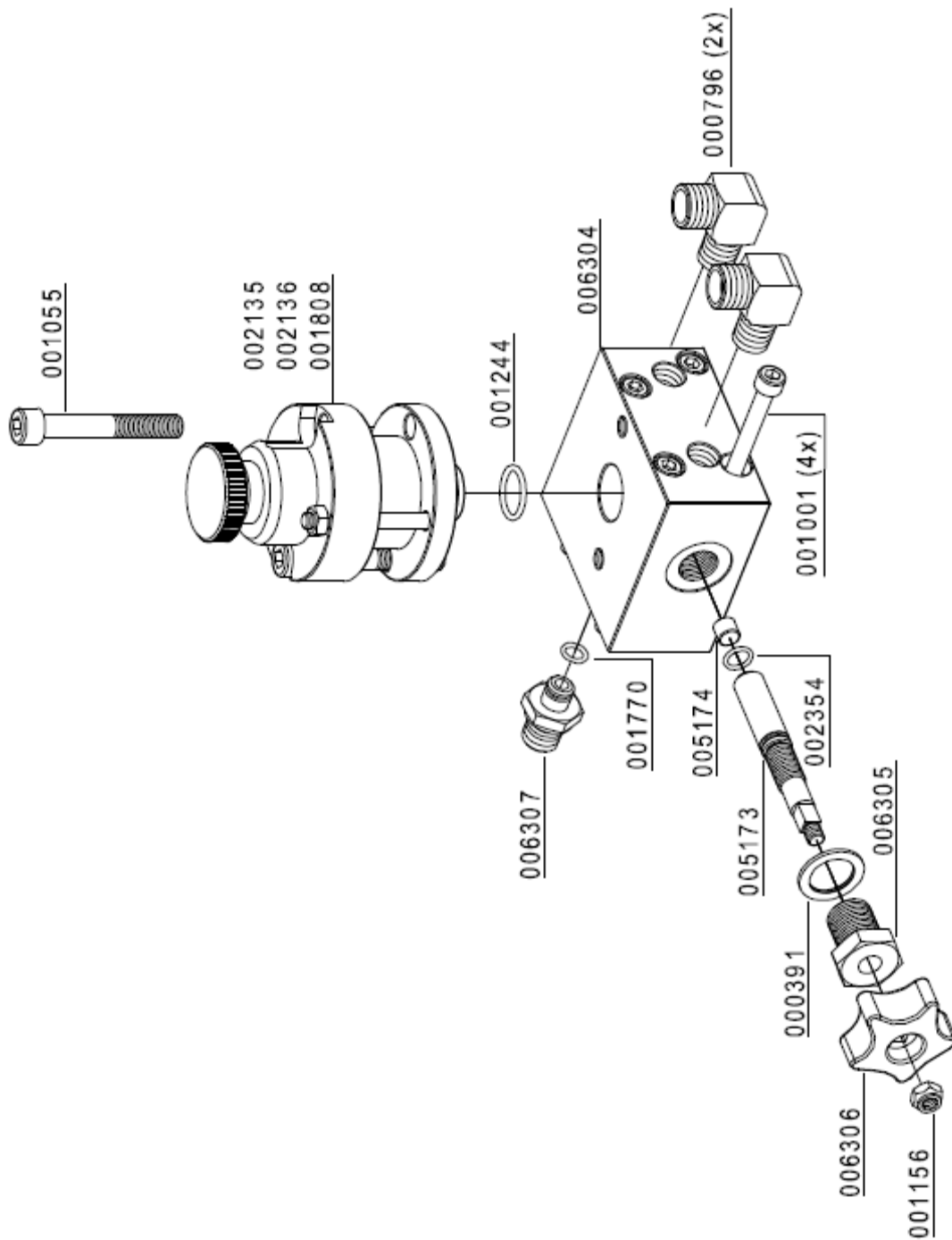

C



**200 / 300 BAR
PARALLEL FILLING
PRESSURE OPERATION**

D

200 / 300 BAR PARALLEL FILLING PRESSURE OPERATION

200 bar / 300 bar parallel filling pressure operation

This option allows the filling of 200 bar and 300 bar at the same time.

In this case, the compressor is equipped with a pressure reducer, a second final pressure safety valve and a second filling pressure gauge.

The handwheels or gaiters are colour-coded to allow an optical differentiation:

- 200 bar: black
- 300 bar: red

Furthermore, the corresponding filling pressures at the compressor are marked with labels.



DIN handwheels 200 bar and 300 bar

D

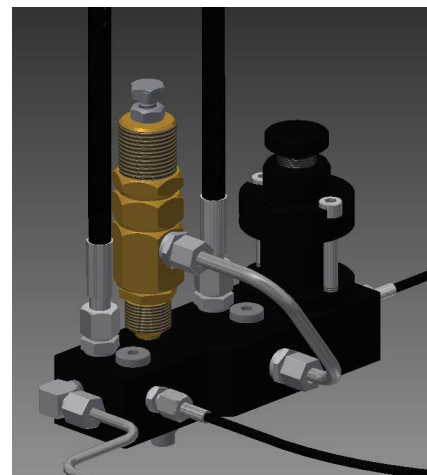

Fig. Pressure reducer: 330 / 225 bar



200 / 300 BAR PARALLEL FILLING PRESSURE OPERATION

Spare Part List

Best.-Nr. / Order No.	Benennung	Description
000553	Sicherheitsventil - Bauteilgeprüft	Safety Valve TÜV 225 bar
000710	Verschraubung	Connection w/o nut& olive seal
000738	Verschraubung	Connection
000750	Verschraubung	Connection with fixed nut
000764	Verschraubung	Connection with fixed nut
000783	Verschraubung	Straight Connection
000838	Verschlussstopfen	Plug
001042	Zylinderschraube	Allen Screw
001058	Zylinderschraube	Allen Bolt
001181	U-Scheibe A8	Washer A8
001428	Druckminderer "High Flow" einstellbar	Pressure Reducer-Bolt version
001814	Sicherheitsventil - Bauteilgeprüft	Safety Valve
008930	Verteilerblock für Parallelfüllbetrieb	Distributor Block, alloy
008931	Verbindungsrohr Parallelfüllbetrieb	Connecting Pipe
008979	Manometerschlauch 1560 mm	Pressure Gauge Hose 1560 mm
008980	Hochdruckschlauch 1340mm	HP-Hose, Length: 1340 mm
008995	Winkelverschraubung	Elbow Connection

D

200 / 300 BAR PARALLEL FILLING PRESSURE OPERATION

Detailed View

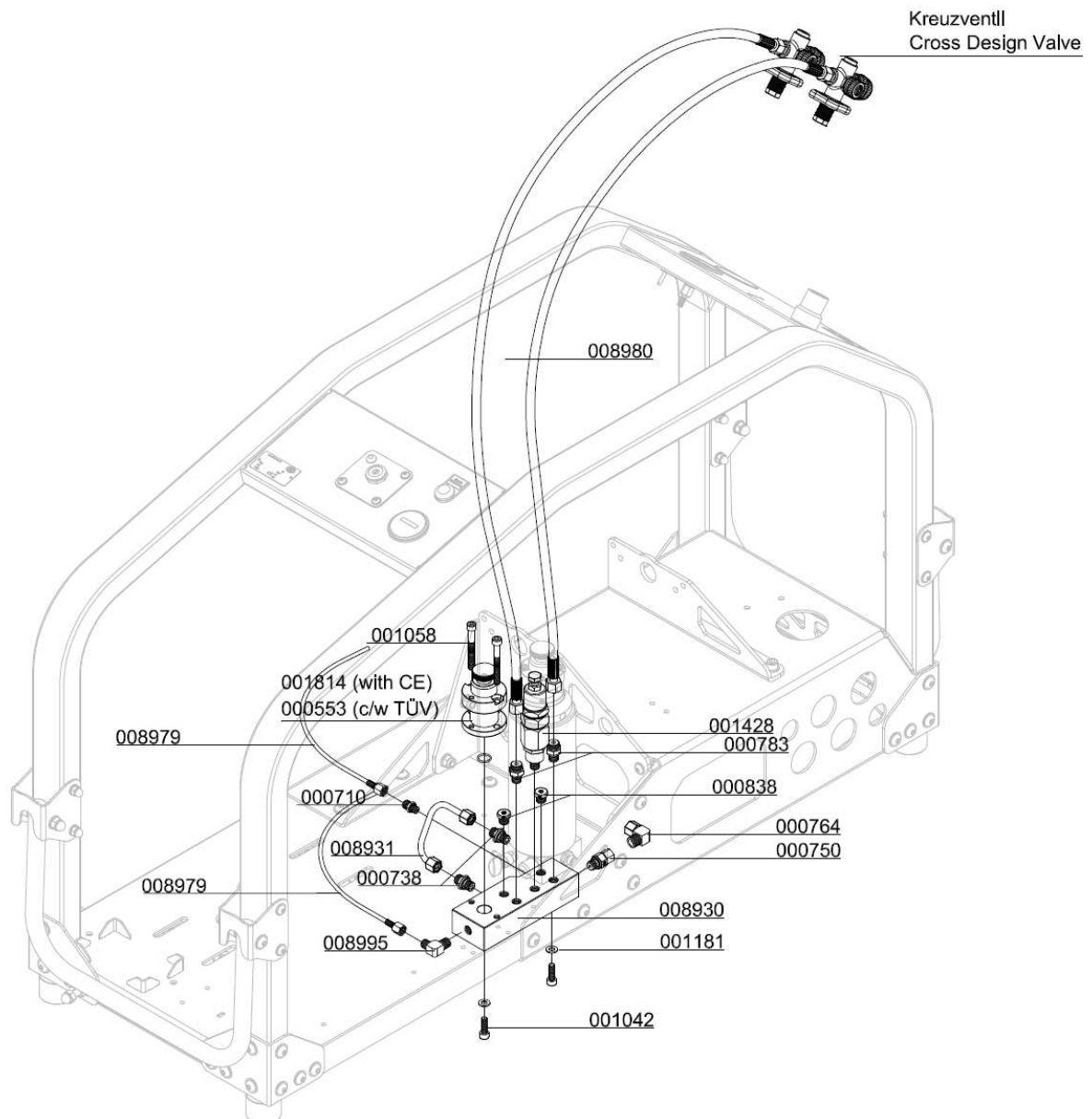

D



OIL PRESSURE GAUGE

D

OIL PRESSURE GAUGE

Oil pressure gauge

The oil pressure gauge shows the compressor oil pressure during operation. Oil pressure values should remain between:

- min. + 2,0 bar
- max. + 3,0 bar

If oil pressure value stays below the minimum value:

- Wrong compressor rotation direction (see rotation direction arrow)
- Oil level too low, not enough oil in the compressor
- Oil pump filter contaminated
- Oil intake pipe damaged / defective
- Oil temperature below +5 °C - lubrication not possible
- Oil temperature higher than +120 °C - oil viscosity too low
- Oil pump defective

If oil pressure value stays above the maximum value:

- Low oil temperature, between +5 °C and +10 °C
- Should stay within the range of tolerance when operation temperature is reached..



Oil pressure gauge

OIL PRESSURE GAUGE

Spare part lists

Best.-Nr. / Order No.	Benennung	Description
000655	Einbaumanometer mit Befestigungsbügel	Press.Gauge, glycerine, brass
000721	Verschraubung	Connection
008934	Manometerschlauch, Minimeßschlauch	Pressure Gauge Hose

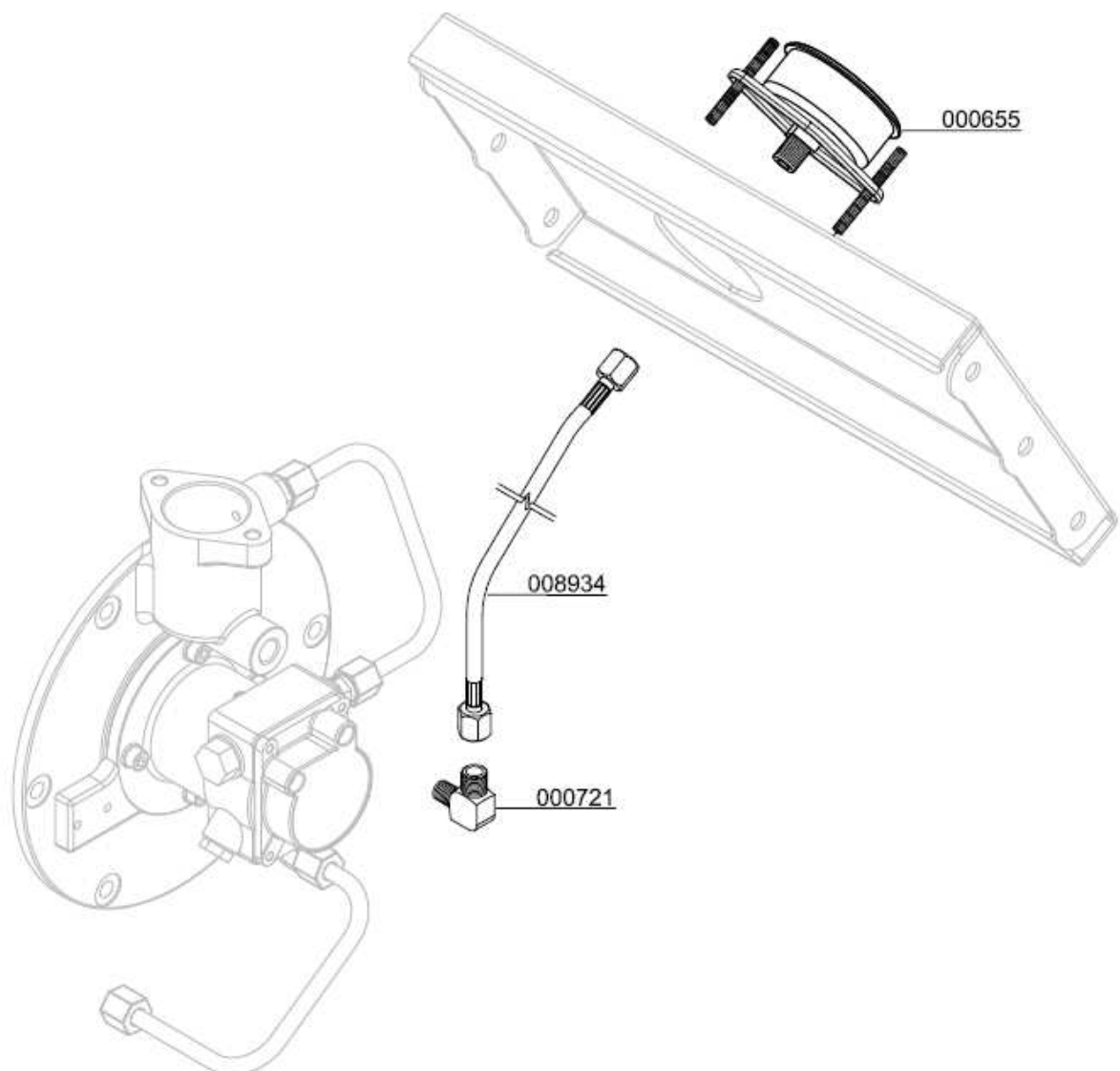

D



OIL PRESSURE MONITORING

D

OIL PRESSURE MONITORING

Oil pressure monitoring

The oil pressure is maintained by a pressure switch during operation. The compressor automatically shuts off when oil pressure decreases below the minimum pressure of +0.5 bar. The red warning lamp "Oil Pressure Monitoring" lights up.

Possible causes of fault:

- Wrong compressor rotation direction
(see rotation direction arrow)
- Oil level too low, not enough oil in the compressor
- Oil pump sieve contaminated
- Oil intake hose damaged / defective
- Oil temperature below +5 °C - lubrication not possible
- Oil temperature higher than +120 °C - oil viscosity too low
- Oil pump defective



Oil Pressure Monitoring



OIL PRESSURE MONITORING

Spare Part List

Best.-Nr. / Order No.	Benennung	Description
000655	Einbaumanometer mit Befestigungsbügel	Press.Gauge, glycerine, brass
000712	Verschraubung	Connection w/o nut& olive seal
000721	Verschraubung	Connection
000732	Mutter	Union Nut 06L
000733	Schneidring 6 mm	Olive Seal SR 06 (Ø 6mm)
001021	Zylinderschraube	Allen Bolt
001176	U-Scheibe A5	Washer A5
001525	Druckschalter	Oil Pressure Switch
008604	VA Rohr "Ölpumpe - Öldruckschalter"	Pipe
008934	Manometerschlauch, Minimeßschlauch	Pressure Gauge Hose

D

OIL PRESSURE MONITORING

Detailed View

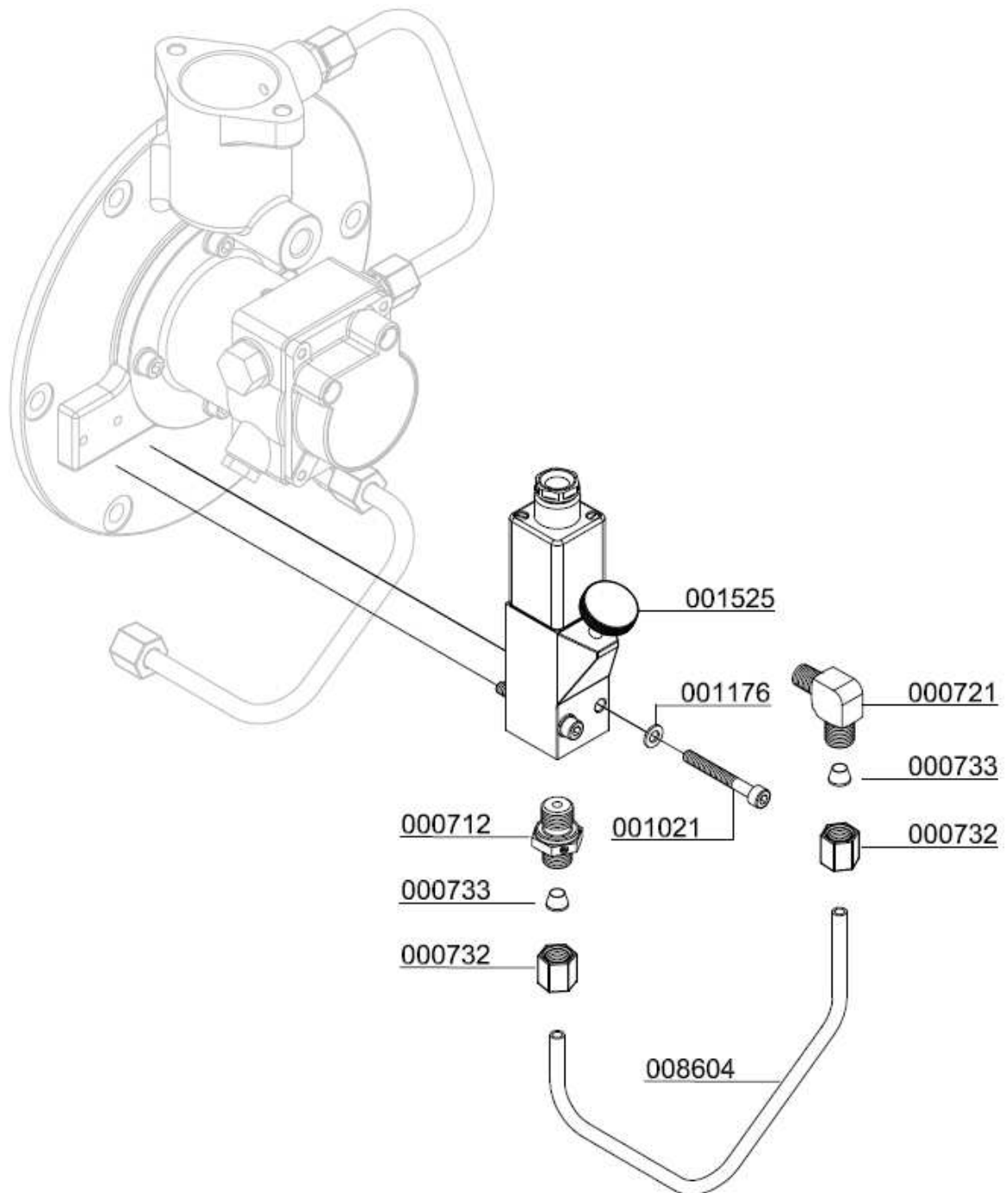

D

OIL PRESSURE MONITORING

Detailed View

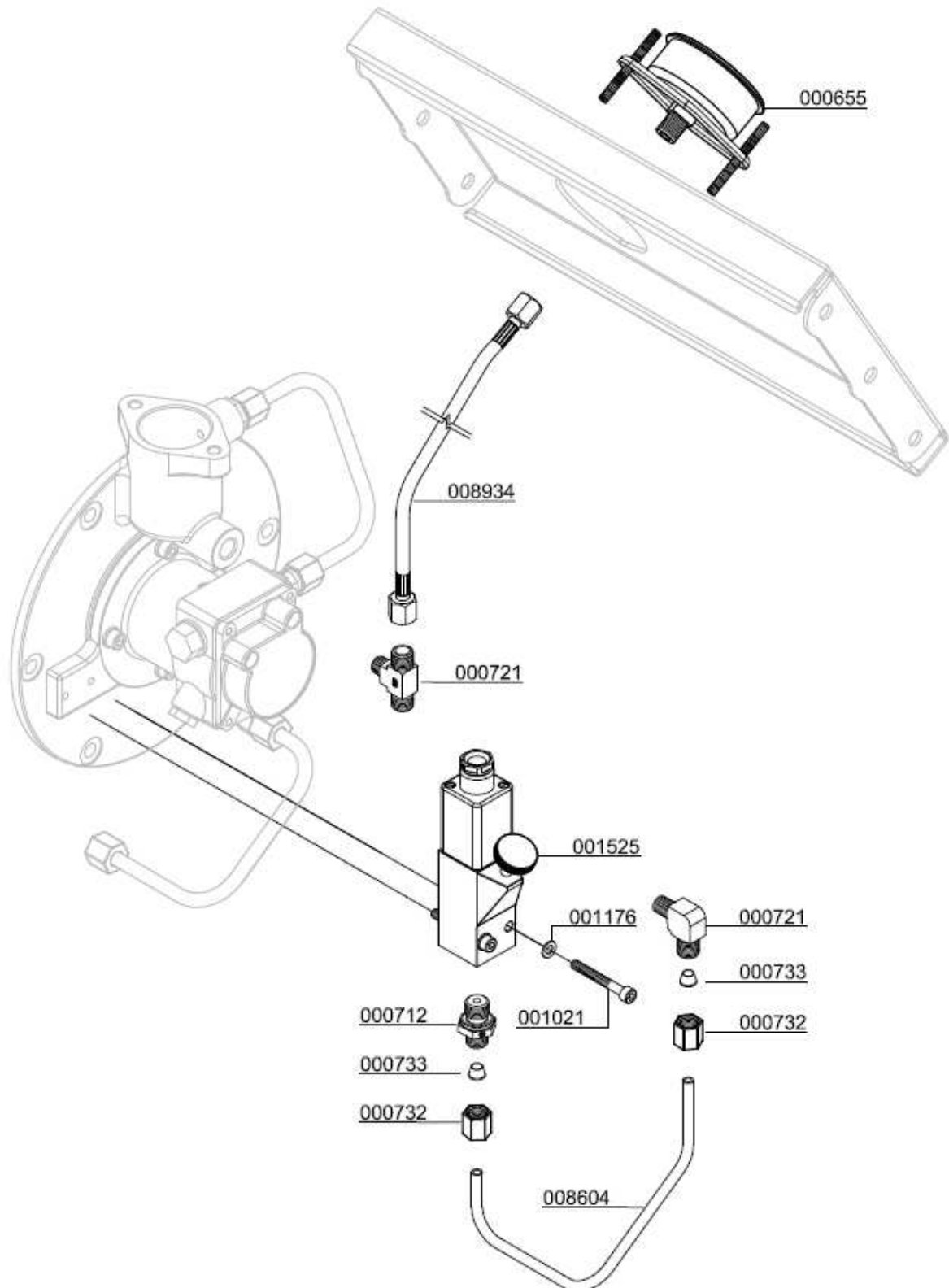

D



OIL PRESSURE MONITORING

Baugruppe: Elektroschaltkasten / Assembly: Electro Box

Best.-Nr. / Order No.	Benennung	Description
000498	U-Scheibe A6	Washer A6
001026	Zylinderschraube	Allen Bolt
001152	Stopfmutter M5	Lock Nut M5
001176	U-Scheibe A5	Washer A5
002090	Betriebsstundenzähler 10-80 V	Hour counter 10-80 V
004688	Befestigungsadapter Wahlschalter	Clamp adapter selector switch
004701	Leuchtmelder, flach, rot	Indicator light, red
004703	Einlegeschild "Öldruck Oil Pressure"	Label "Oil Pressure"
004704	LED-Element, Front, rot, Kontrollleuchte	LED, red, indicator light
005135	Schlauchschelle	Hose clamp
006090	Flachkopfschraube	Cross Cheese Head Screw
006859	Klemmrahmen (Schildträger)	Label holder
008778	Batterie	Battery 12V, 9 Ah
008971	Kabeldurchführung	Grommet
008972	Rittal Klemmgehäuse	Terminal Box
008974	Kabelschutzschlauch FPAS 28	Cable Protection Hose, 470mm
008975	Kabelverschraubung mit Mutter	Cable Glands with Nut
008976	Kabelverschraubung mit Mutter	Cable Glands with Nut
009234	Quertraverse	Transv. traverse (motor side)
009238	Schlüsselschalter	Keyswitch
009240	Halteblech Batterie	Bracket, Battery

D



INTERSTAGE PRESSURE GAUGE

D

INTERSTAGE PRESSURE GAUGE

Interstage pressure gauge

Each of the 3 pressure stages is monitored by a single pressure gauge. This is serviceable for troubleshooting and allows detecting faults at an early stage.

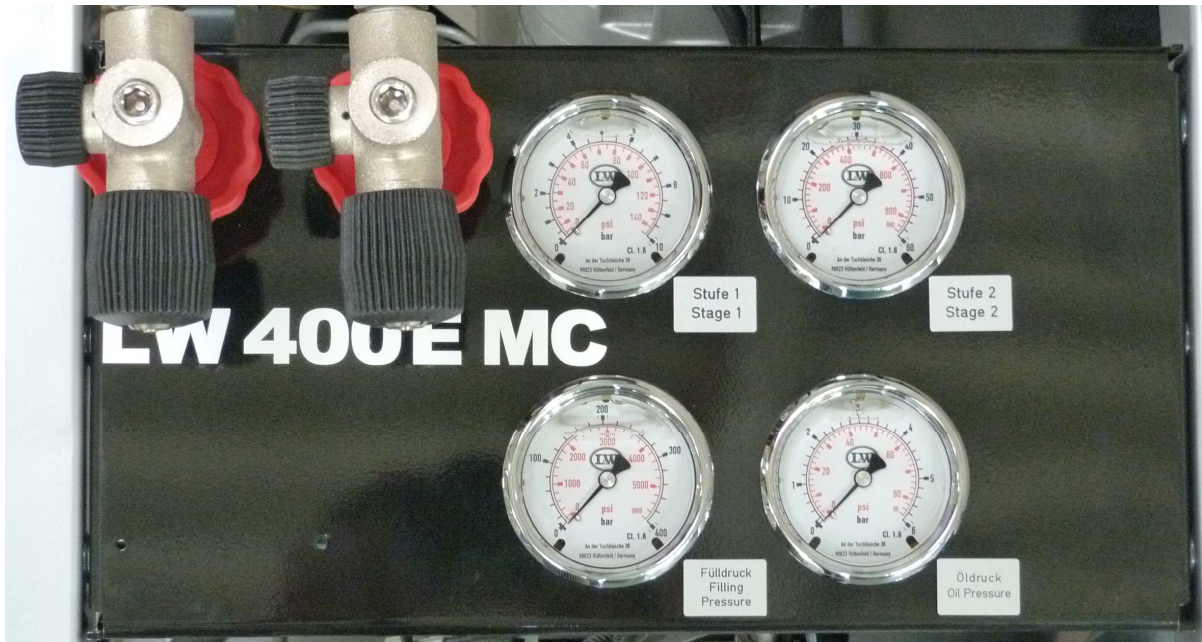

Indicated interstage pressures depend on final pressure settings.

The pressure gauges should show the following values at a final pressure of 300 bar:

1st stage: approx. 6 bar

2nd stage: approx. 58 bar

3rd stage: approx. 300 bar



INTERSTAGE PRESSURE GAUGE

Spare Part List

Best.-Nr. / Order No.	Benennung	Description
000663	Einbaumanometer mit Befestigungsbügel	Press. Gauge c/w fixing strap
000710	Verschraubung	Connection w/o nut& olive seal
000721	Verschraubung	Connection
002507	Einbaumanometer glyzeringefüllt	Pressure Gauge 0-10bar
005539	Einbaumanometer glyzeringefüllt	Pressure Gauge 0-100bar
008925	Quertraverse Füllventil	Transv. traverse (fil. valve)
008935	Manometerschlauch, Minimeßschlauch	Pressure Gauge Hose, 290 mm

D

INTERSTAGE PRESSURE GAUGE

Detailed View

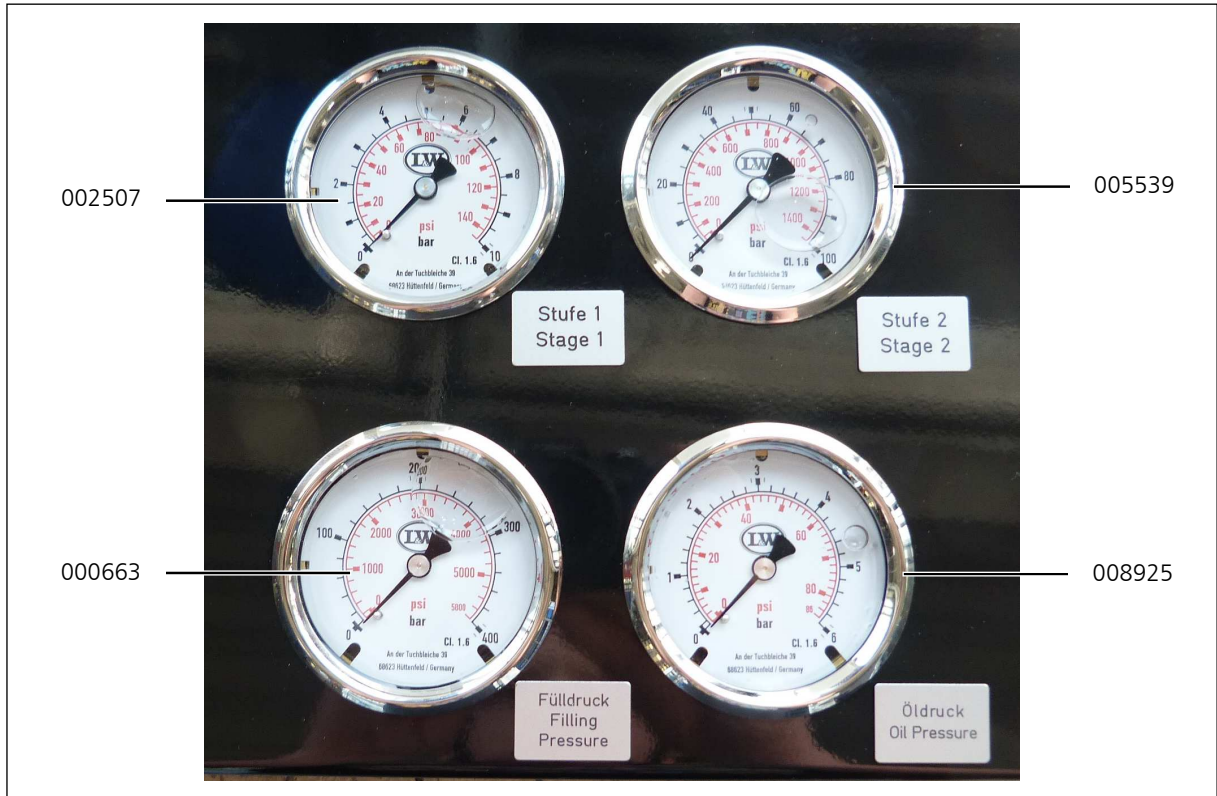

D

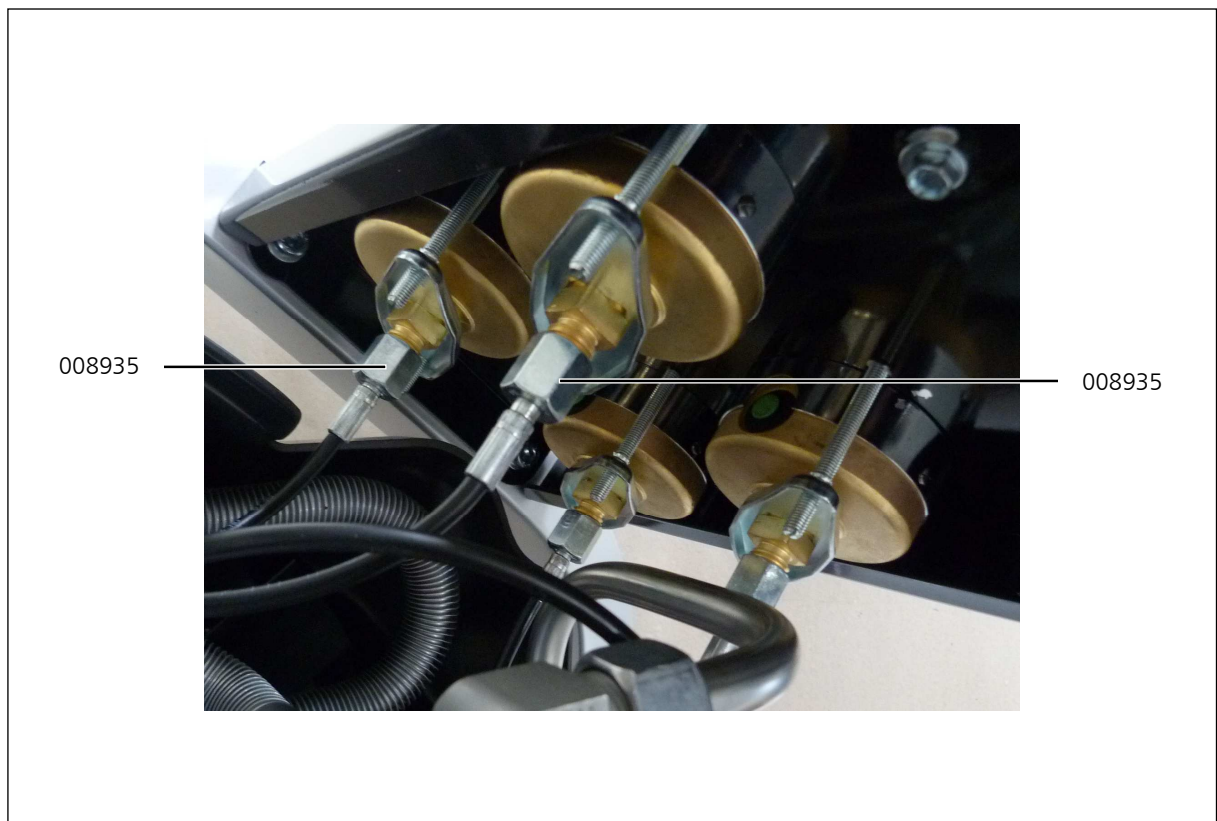

INTERSTAGE PRESSURE GAUGE

Detailed View

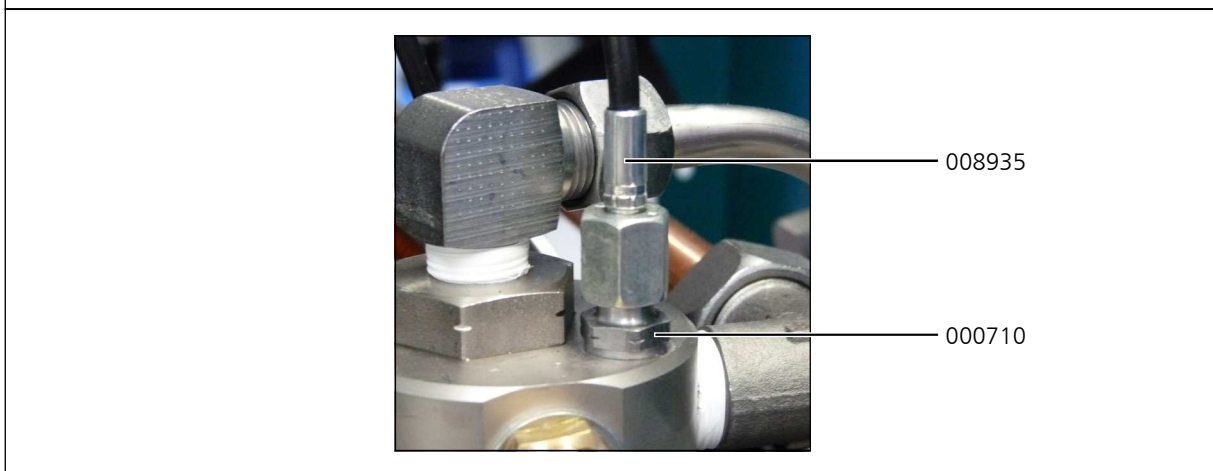

D



CYLINDER HEAD TEMPERATURE MONITORING

D

CYLINDER HEAD TEMPERATURE MONITORING

Cylinder head temperature monitoring

The cylinder head temperature is maintained by a temperature sensor at the cylinder head of the high pressure stage during operation. The compressor shuts off automatically when cylinder head temperature exceeds the maximum pressure of +160° C. The red warning lamp "Cylinder Head Temperature Monitoring" lights up.

Possible causes of fault:

- Ventilation of the compressor room is not sufficient
- Cooling air flow not sufficient
- Cooling pipes contaminated



Warning

Risk of burns!

Allow the unit to cool before beginning troubleshooting.

CYLINDER HEAD TEMPERATURE MONITORING

Spare part lists

Best.-Nr. / Order No.	Benennung	Description
004726	Display	Display
005585	Sensor	Sensor
007444	Ventilkopf (Spezielle Version)	Valve Head (special version)

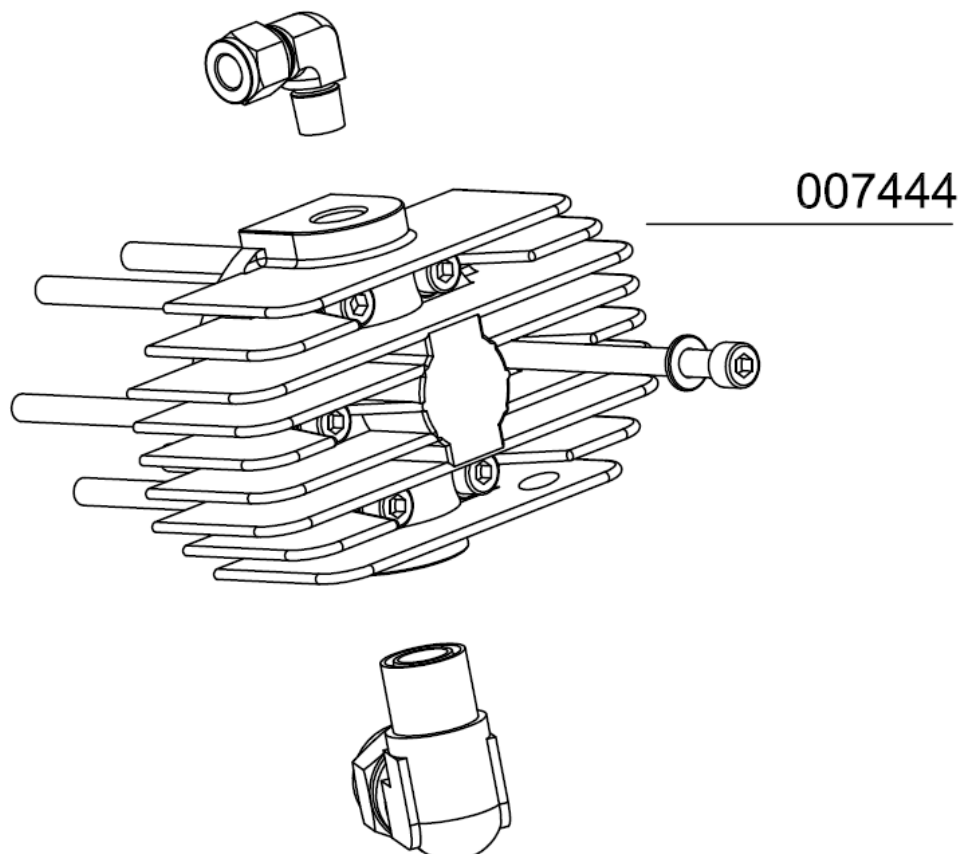
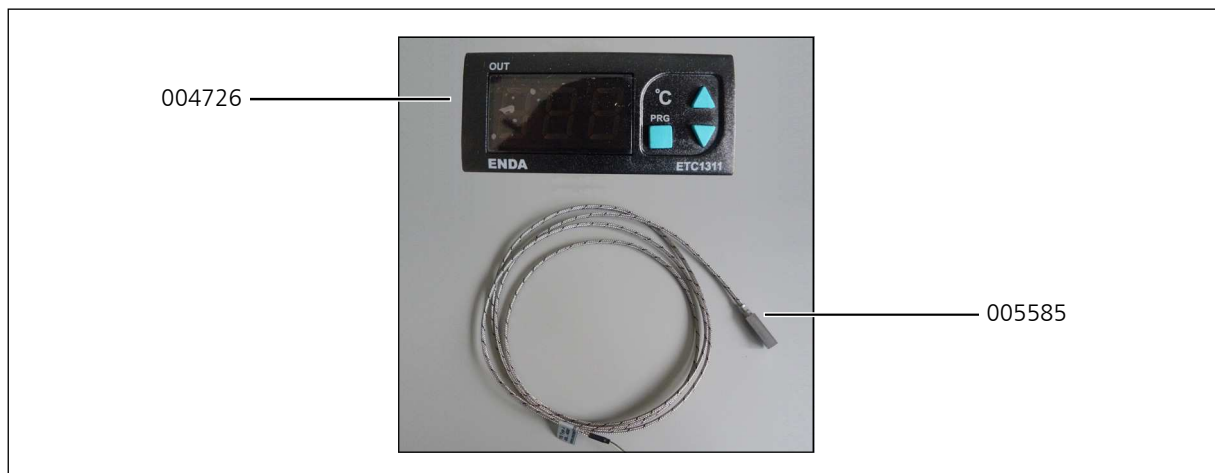



AIR COOLER CONNECTION KIT

D

AIR COOLER CONNECTION KIT

Air cooler connection kit

The Air Cooler Connection Kit provides an easy connection and a simple and time-saving installation or backfitting.

The piping inside the compressor is completely installed. Just disconnect the U-connection at the outside and connect the air cooler according to the connection designation (inlet/outlet).

How to connect the air cooler connection kit.

- Connect the outlet of the air cooler adapter to the inlet of the air cooler.
- Connect the inlet of the air cooler adapter to the outlet of the air cooler.

To operate the unit without air cooler, reinstall the U-connection and the compressor is ready for use.

Connecting hoses

The Air Cooler Connection Kit does not include high pressure hoses. We offer different length and specification. Please ask for details.

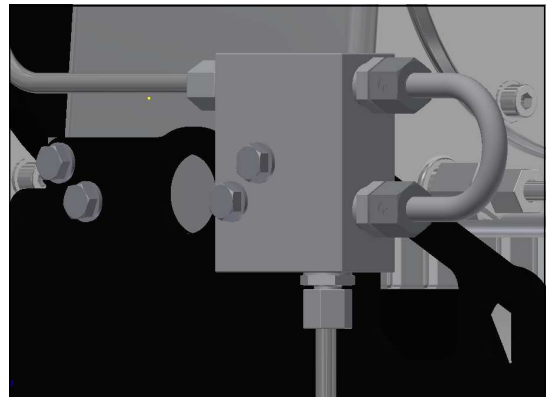

Air cooler connection kit



AIR COOLER CONNECTION KIT

Spare Part List

Best.-Nr. / Order No.	Benennung	Description
000738	Verschraubung	Connection
000783	Verschraubung	Straight Connection
001055	Zylinderschraube	Allen Bolt
001181	U-Scheibe A8	Washer A8
008949	Rippenrohrkühler 3. Stufe	Finned Cooler Pipe 3rd Stage
008950	Verbindungsrohr, VA Ø8mm	Connecting Pipe, Air Cooler
008951	Verbindungsrohrbogen, VA Ø10mm	Connecting Pipe, Air Cooler
008952	Adapter Air Cooler	Adapter Air Cooler

D

AIR COOLER CONNECTION KIT

Detailed View

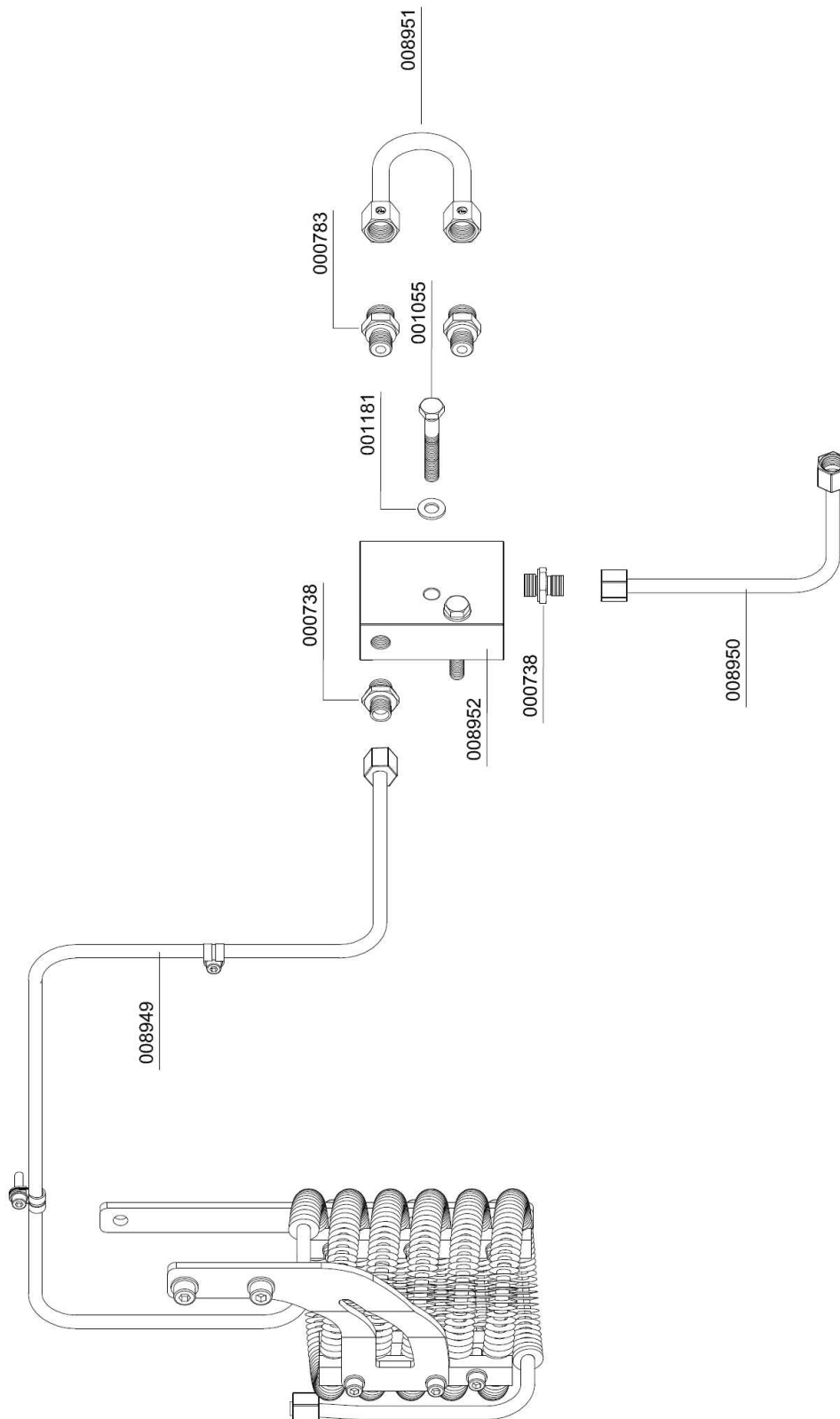

D



ATTACHMENT

E

Lenhardt & Wagner GmbH

**An der Tuchbleiche 39
D-68623 Lampertheim – Hüttenfeld**

www.lw-compressors.com



Operating Instruction

Safety valve

Typ:

SiV2 BKZ 989 TÜV.SV.12-989.5.G.V.P CE 0091 AlMgSi1 F31 1100* Lenhardt & Wagner

SiV BKZ TÜV.SV.14-1140.5.G.V.p CE 0091 AlMgSi1 F31 1100* Lenhardt & Wagner

Set pressure:	see mark (hand wheel on top of valve)
Maximum outflow:	Set pressure 100-159 bar: 750 l / min Set pressure 160-350 bar: 1.100 l / min
Suitable media:	Media-resistant, non-corrosive gases

The safety valve is used for protection of pressurized components, eg pipelines, pressure vessels, or the compressor itself.

The hand wheel on the top of the safety valve is marked with the adjusted set pressure.



Safety valve with socket

- 1) *Identification of set pressure*
- 2) *Seal*
- 3) *Fixing screws¹*
- 4) *Venting screw (hand wheel)*
- 5) *Identification serial number*
- 6) *Socket for safety valve*

¹ und die Anforderungen des AD 2000 Merkblatts W7 erfüllen. Schaftlänge 70mm. The fixing screws M8 must be strength class 8.8 and meet the requirements of Merkblatt AD 2000 leaflet W7. Shaft length 70mm.

In order to prevent manipulation of the set pressure, all safety valves are factory fitted with a seal.

A safety valve on which the seal has been removed, must be returned before further use to the manufacturer for repair / adjustment.

In addition, the safety valve has a venting device (hand wheel).

In the rotation direction clockwise, the safety valve and herewith also the filter housing of the final stage could be completely vented.

During normal operation, the screw is unscrewed to the upper stop anticlockwise, an integrated safety ring prevents that the screw can be completely unscrewed.

If a safety valve blow off, the system must be switched off immediately and investigate the cause of the error.

There are two possible reasons:

1. The safety valve is defective and blows off before the set pressure.

In this case the safety valve should be submitted immediately to the manufacturer for repair or replaced with a new one.

2. The safety valve opens properly, the problem is on the system.

A constant blowing of the safety valve is not permitted, the sealing seat of the valve can be damaged. The error on the system must be detected and repaired before further filling operations.

The safety valve may only be used if it is ensured that the maximum flowrate of the system does not exceed the blowoff rate of the safety valve.

The safety valve may only be used with the approved media.

Repair work on compressors must only be performed by trained personnel.

Dismantling of the safety valve

Ensure that on the safety valve is no pressure.

Loosen and remove the two M8 fixing bolts with a 6mm Allen key.

The safety valve can now be removed by turning and simultaneously pulling out of the socket.

Mounting

1. Clean the safety valve socket.

2. Oil the insert pin of the safety valve including the O-ring with 1 to 2 drops of oil.

3. Press the safety valve pin complete into the socket.

4. Fasten the safety valve with the two 8 mm allen screws into the socket

(Tightening torque: 10 Nm)

5. Screw the venting screw (hand wheel) anticlockwise to its upper limit.

6. Start the System (Compressor), check installation for leaks and proper function.

Manufacturer: Lenhardt & Wagner GmbH
An der Tuchbleiche 39
D-68623 Lampertheim – Hüttenfeld

Kontakt: E-Mail: service@lw-compressors.com
Web: www.lw-compressors.com
Tel.: +49 (0) 6256 – 85880 0
Fax: +49 (0) 6256 – 85880 14

Note:

*Use the safety valve only in a technically perfect condition, for its intended purpose, safety and danger awareness, in compliance with the operating instructions!
Especially disorders which could affect safety must be remedied immediately!*

Notes:

- The safety valve must be installed directly on the protected pressure vessel and / or the plant.
 - The safety valve must be installed in an upright position.
 - The flow area of the port must be greater than the valve opening.
 - Protect valve against splashes
-

Maintenance:

- The safety valve is periodically - in accordance with the currently valid Pressure Equipment Directives - to check on operation and reliability.
- Refill annually lubricating oil:
Oil filling position:
Hole on the spacer (see arrow, Figure 1)
- Oil level: Fill oil into the hole until oil comes out of the hole.

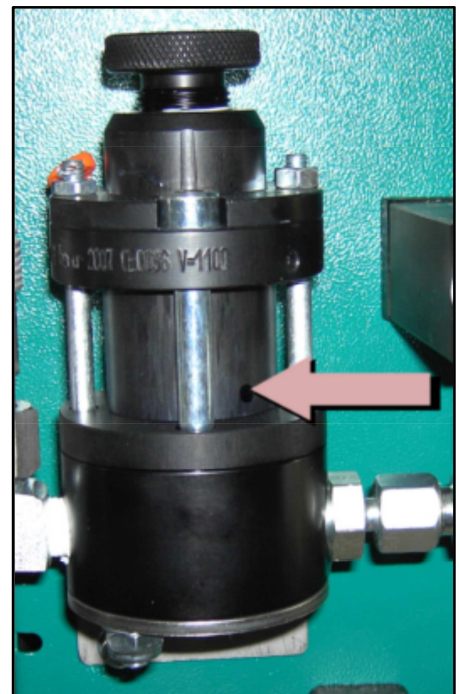

Figure 1: Position for oil refill

To be used lubricating oil for the safety valve: L&W Article Nr.: 008500 (content: 30 ml)
