



CHAPTER OVERVIEW

| | |
|--|----------|
| Operating Instructions | A |
| ECC - Electronic Compressor Control (if equipped) | B |
| Spare Parts Lists | C |
| Options (if equipped) | D |
| Attachment | E |

Manufacturer in terms of 97/23/EC

The full name and address of the manufacturer is:

Lenhardt & Wagner GmbH

An der Tuchbleiche 39
68623 Hüttenfeld / Germany

Phone: +49 (0) 62 56 - 85 88 0 - 0

Fax: +49 (0) 62 56 - 85 88 0 - 14

E-Mail: service@lw-compressors.com

Internet: www.lw-compressors.com





SERVICE INFORMATION / WARRANTY

Compressor information

Type designation

Serial number

Date of construction

Purchase information

Purchase date

First commissioned on

Warranty period

Dealer's stamp

Warranty

L&W will uphold warranty claims made during a period of 12 months from the invoice date.

If the compressor was purchased from an official L&W dealer, the date on the dealer's invoice is valid. Warranty claims can only be made on presentation of the original invoice.

Should verifiably defective parts have been delivered, we will decide to either replace the parts or repair them. The resulting transport and assembly costs will be invoiced.

No reduction of the purchase price or changes to the contract can be made. The parts for which a claim is being made should be kept safe by the purchaser and, when requested, sent to us at their cost. Replaced parts become the property of L&W. If maintenance work is carried out without our knowledge or permission by the purchaser or a third party, we are absolved from any liability for warranty claims. As a matter of principle, warranty claims can only be made by the initial purchaser.

Operating Instructions

Breathing Air Compressor

LW 230 ES / LW 280 ES / LW 320 ES





TABLE OF CONTENTS

General Information and Technical Data

| | |
|--|---|
| General Information / Description of Warning Symbols | 4 |
| Scope of Delivery | 5 |
| Technical Data | 6 |
| Unit Assembly | 7 |
| Switchboard | 8 |
| Flow chart | 9 |

Safety Precautions

| | |
|--|----|
| Intended Use / Operators | 11 |
| Safety instructions on the unit | 12 |
| General Safety Precautions | 13 |
| Unit customised safety notices | 14 |
| Maintenance instructions | 15 |
| Transportation instructions / Safety regulations | 16 |

Installation

| | |
|------------------------------------|---------|
| Installation in closed rooms | 18 |
| Dimensions | 19 |
| Minimum distances | 20 |
| Ventilation | 21 |
| Electrical Installation | 22 - 23 |

Operation

| | |
|--|---------|
| Important operation instructions | 25 |
| First commissioning | 26 - 28 |
| Daily commissioning | 29 |
| Filling procedure | 30 |
| Switch off the compressor | 31 |

| | |
|-------------------------------|---------|
| Remedying faults | 32 - 36 |
|-------------------------------|---------|

Maintenance and Service

| | |
|---|---------|
| Service, Repair and Maintenance | 38 |
| Maintenance Lists / Maintenance Intervals | 39 - 42 |
| Service Kits | 43 |
| Check V-belt tension / Tension V-belt | 44 |
| Compressor lubrication / Check oil level | 45 |
| Oil change | 46 |
| Oil filter maintenance | 47 |
| Final pressure switch | 48 |

A



TABLE OF CONTENTS

Maintenance and Service

| | |
|--|---------|
| Automatic condensation dump system | 49 |
| Oil / Water separators 1st and 2nd stage - maintenance | 50 |
| Oil / water separators final stage - maintenance | 51 |
| Pneumatic condensate valve - maintenance | 52 |
| Filter housing / Filter cartridge | 53 |
| Filter cartridge change | 54 |
| Filter housing - Maintenance | 55 |
| Inlet filters / Inlet filter cartridge change | 56 |
| Cylinder heads and valves | 57 |
| Replace inlet and outlet valve 1st stage | 58 - 59 |
| Replace inlet and outlet valves 2nd and 3rd stage | 60 |
| Safety valves | 61 |
| Pressure maintaining / non return valve | 62 |
| Safety valve test | 63 |
| Leak test | 64 |
| Pressure gas vessel test | 65 |
| Maintenance records | 66 - 71 |

Storage

| | |
|--|----|
| Conservation / storage of the compressor | 72 |
| De-conservation, commissioning | 72 |
| Transportation instructions / Disposal | 73 |

A

GENERAL INFORMATION

General Information

We strongly recommend reading this manual thoroughly prior to operation and follow all the safety precautions precisely. Damage resulting from any deviation from these instructions is excluded from warranty and liability for this product. Carry out other commissioning steps only if you have fully understood the following contents.

Before commissioning and using the unit, carry out all the essential preliminary work and measures concerning legal regulations and safety. These are described on the following pages of this operation manual.

A

Description of marks and warning signs

The following warning signs are used in this document to identify the corresponding warning notes which require particular attention by the user. The warning signs are defined as follows:



Caution

Indicates an imminently hazardous situation which, if not avoided, could result in serious injury, physical injury or death.



Warning

Indicates a potentially hazardous situation which, if not avoided, could result in physical injury or damage to the product or environment.



Note

Indicates additional information on how to use the unit.



DESCRIPTION

Scope of Delivery

Compressors are provided in different equipped versions.

Versions

Filling pressure versions:

- PN 225 bar
- PN 330 bar
- PN 225 / 330 bar

Specifications

- Sound insulated housing
- Automatic condensate drain
- Automatic stop at final pressure
- Hour counter
- Operating panel with start/stop and condensate test button, as well emergency stop switch
- 2 x Filling hose c/w filling valve
- Motor protection switch (LW 230 Optional)
- Pressure maintaining and non return valve
- All pistons c/w steel piston rings
- Low pressure oil pump and filter
- Oil- / Water separators in stainless steel
- Safety valves after each stage
- 3 x concentric suction/pressure valves
- Filling pressure to your choice (200 or 300 bar)

Options

- Auto start system
- Up to 6 additional hoses available
- 200 and 300 bar parallel filling pressures
- Oil pressure gauge
- Intermediate pressure gauges
- Oil pressure monitoring c/w auto shut down
- Cylinder head temperature monitoring with auto shut down
- Oil temperature display with auto shut down
- Puracon filter monitoring (Auto shut down also available)
- ECC control
- Phase monitoring c/w shut down at wrong direction of rotation
- Additional high pressure outlet
- Power cable and plug

DESCRIPTION

Technical Data



A

| Technical Data | LW 230 ES | LW 280 ES | LW 320 ES |
|---|--------------------------------|--------------|--------------|
| Capacity [l/min]: | 230 | 280 | 320 |
| Max. Operating Pressure [bar]: | 350 | 350 | 350 |
| RPM [min ⁻¹]: | 1080 | 1300 | 1450 |
| Number of Pressure Stages: | 3 | 3 | 3 |
| Cylinder Bore 1st Stage [mm]: | Ø 95 | Ø 95 | Ø 95 |
| Cylinder Bore 2nd Stage [mm]: | Ø 40 | Ø 40 | Ø 40 |
| Cylinder Bore 3rd Stage [mm]: | Ø 18 | Ø 18 | Ø 18 |
| Medium: | Compressed Air / Breathing Air | | |
| Intake Pressure: | atmospheric | | |
| Oil Pressure [bar]: | +0.6 to +4.0 | +0.6 to +4.0 | +0.6 to +4.0 |
| Oil Capacity [l]: | 1.8 | 1.8 | 1.8 |
| Intake Temperature [°C]: | 0 < +45 | 0 < +45 | 0 < +45 |
| Ambient Temperature [°C]: | +5 < +45 | +5 < +45 | +5 < +45 |
| Cooling Air Volume [m ³ /h]: | > 1650 | > 2250 | > 2250 |
| Voltage: | 400 V / 3 phase / 50 Hz | | |
| Protection Class Drive Motor: | IP 54 | IP 54 | IP 54 |
| Drive Power [kW]: | 5.5 | 7.5 | 7.5 |
| RPM Motor [min ⁻¹]: | 2890 | 2890 | 2890 |
| Start: | Star/Delta | | |
| Noise level from a distance of 1 m [dB(A)]: | 61 | 61 | 61 |
| Dimensions W x D x H [mm]: | 760 x 1030 x 1630 | | |
| Weight [kg]: | approx. 330 | approx. 330 | approx. 330 |
| Content Volume Filter housing [l]: | 1.7 | 1.7 | 1.7 |

DESCRIPTION

Unit Assembly



A

| No. | Designation |
|-----|---|
| 1 | Filling pressure gauge |
| 2 | Switchboard |
| 3 | Filter Housing |
| 4 | Pressure maintaining / non return valve |
| 5 | Lever filling valve |
| 6 | Filling hoses |
| 7 | Filling connector |

DESCRIPTION

Switchboard

A



| No. | Designation |
|-----|---------------------------|
| 1 | Emergency shut-off switch |
| 2 | Hour counter |
| 3 | ON button |
| 4 | OFF button |
| 5 | Drain test button |

DESCRIPTION

Flow chart

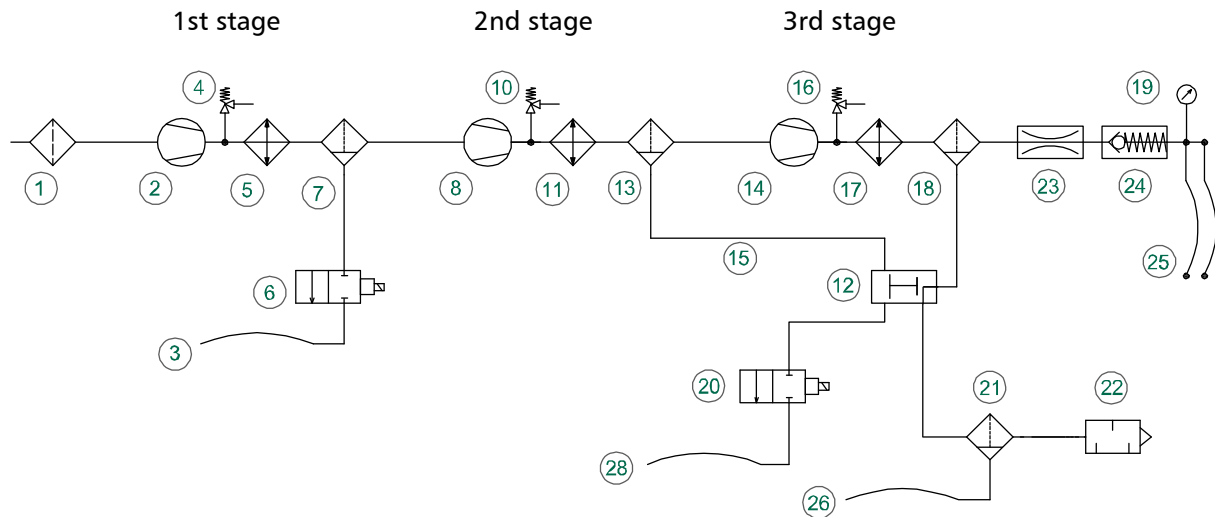

- | | |
|---|--|
| 1. Ansaugfilter / Air Intake Filter | 16. Sicherheitsventil 3. Stufe / Safety Valve 3rd Stage |
| 2. 1. Verdichterstufe / 1st Pressure Stage | 17. Wärmetauscher / Heat Exchanger |
| 3. Kondensatablaßschlauch / Condensate Drain Hose | 18. Öl-/Wasserabscheider / Oil-/Water Separator |
| 4. Sicherheitsventil 1. Stufe / Safety Valve 1st Stage | 19. Druckmanometer (Fülldruck) / Pressure Gauge (Filling Pressure) |
| 5. Wärmetauscher / Heat Exchanger | 20. Magnetventil / Solenoid Valve |
| 6. Magnetventil / Solenoid Valve | 21. Öl-/Wasserabscheider / Oil-/Water Separator |
| 7. Öl-/Wasserabscheider / Oil-/Water Separator | 22. Schalldämpfer / Silencer |
| 8. 2. Verdichterstufe / 2nd Pressure Stage | 23. Druckhalteventil / Pressure Maintaining Valve |
| 10. Sicherheitsventil 2. Stufe / Safety Valve 2nd Stage | 24. Rückschlagventil / Non-Return Valve |
| 11. Wärmetauscher / Heat Exchanger | 25. Hochdruckschlauch / HP-Hose |
| 12. Pneumatisches Kondensatventil / Pneumatic Condensate Valve | 26. Kondensatablaßschlauch / Condensate Drain Hose |
| 13. Öl-/Wasserabscheider / Oil-/Water Separator | 28. Kondensatablaßschlauch / Condensate Drain Hose |
| 14. 3. Verdichterstufe / 3rd Pressure Stage | |
| 15. Steuer- / Entlüftungsleitung 2. Stufe / Control pressure / Condensate drain 2nd stage | |



A

SAFETY PRECAUTIONS



SAFETY PRECAUTIONS

Intended Use

Only use the unit in perfect condition for its intended purpose, safety and intended use and observe the operating instructions! In particular disorders that may affect safety have to be eliminated immediately!

Use the unit exclusively for the determined medium (see "Technical Data"). Any other use that is not specified is not authorized. The manufacturer/supplier shall not be liable for any damages resulting from such use. Such risk lies entirely with the user. Authorization for use is also under the condition that the instruction manual is complied with and inspection and maintenance requirements are enforced.

No change and modification to the unit can be made without the written agreement of the manufacturer. The manufacturer is not liable for damage to persons or property resulting from unauthorized modifications.

Operators

Target groups in these instructions;

Operators

Operators are persons who are authorized and briefed for the use of the compressor.

Qualified personnel

Qualified personnel are persons who are entitled to repair, service, modify and maintain the system.



Warning

Only trained personnel are permitted to work on the unit!



Warning

Work on the electrical equipment on / with the machine / unit may only be carried out by qualified electricians.

SAFETY PRECAUTIONS

Safety instructions on the unit

Importance of notes and warning signs that are affixed to the compressor according to the application or its equipment.

A



Warning
High voltage!

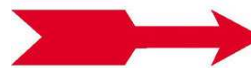

Note
Ensure correct direction of rotation!



SAFETY PRECAUTIONS

General Safety Precautions

- Read the Operating Instructions of this product carefully prior to use.
- Strictly follow the instructions. The user must fully understand and strictly observe the instructions. Use the product only for the purposes specified in the intended use section of this document.
- Do not dispose the operating instructions. Ensure that they are retained and appropriately used by the product user.
- Only trained and competent personnel are permitted to use this product.
- Comply with all local and national rules and regulations associated with this product.
- Only trained and competent personnel are permitted to inspect, repair and service the product.
- Only authentic L&W parts and accessories may be used for maintenance work. Otherwise, the proper functioning of the product may be impaired.
- Do not use faulty or incomplete products. Do not modify the product.
- Inform L&W in the event of any product or component fault or failure.
- The quality of the air supply must meet EN 12021 specifications for breathing air.
- Do not use the product in areas prone to explosion or in the presence of flammable gases. The product is not designed for these applications. An explosion might be the result if certain conditions apply.

A



SAFETY PRECAUTIONS

Unit customised safety notices

Organisational measures

- In addition to the instruction manual, observe and comply with universally valid legal and other obligatory regulations regarding accident prevention and environment protection.
- In addition to the instruction manual, provide supplementary instructions for supervision and monitoring duties taking into consideration exceptional factors e.g. with regard to organisation of work, production, personnel employed.
- Supervise personnel's work in accordance with the instruction manual, taking into account safety and danger factors.
- Observe all safety and danger notices on the compressor and check readability and completeness.

Safety instructions operation

- Take measures to ensure that the machine is only taken into operation under safe and functional conditions. Only operate the compressor if all protective and safety equipment, e.g. detachable protective equipment, are provided and in good working order.
- Check the compressor at least once per day for obvious damage and defects. Inform the responsible department / person immediately if anything is not as it should be (including operation performance). Shut down the machine immediately if necessary and lock it.
- In case of malfunction, stop the compressor immediately and lock it. Repair malfunctions immediately.
- If there is a failure in the electric energy supply, shut the machine / unit down immediately.
- Ensure safe and environmentally friendly disposal of consumables and old parts.
- The stipulated hearing protectors must be worn.
- Soundproofing equipment on the compressor has to be activated in safety function during operation.
- When handling with fats, oils and other chemical agents, observe the note for the product-related safety.

A



SAFETY PRECAUTIONS

Maintenance instructions

- Hoses have to be checked by the operator (pressure and visual inspection) at reasonable intervals, even if no safety-related defects have been detected.
- Immediately repair any damage. Escaping compressed air can cause injury.
- Depressurise system and pressure lines before beginning repair work.
- Pressurised air lines must be laid and mounted by qualified personnel. Connections must not be mixed up. Fittings, length and quality of the piping must correspond to requirements.
- Adjustment, maintenance and inspection activities and keep appointments, including information on replacement parts / equipment, prescribed in the operating instructions have to be respected.
- If the machine / equipment is completely off during maintenance and repair work, it must be protected against unexpected restart. Turn off main control device and remove the key and/or display a warning sign on the main switch.
- The machine and especially the connections and fittings should be cleaned from oil, fuel and maintenance products at the beginning of the maintenance / repair. Do not use aggressive cleaning agents. Use fibre-free cleaning cloths.
- Switch off compressor and clean with a slightly damp cloth. Remove dirt from cooling pipes by using a brush.
- After cleaning, examine all pipes for leaks, loose connections, chafing and damage. Immediately eliminate any faults.
- Always retighten any screw connections loosened for maintenance or repair work.
- If it is necessary to remove safety devices for maintenance and repair work, these must be replaced and checked immediately after completion of the maintenance or repair work.
- The electrical equipment of the compressor must be regularly checked. Defects, such as loose screw connections or burnt wires, must be immediately rectified by electrically skilled personnel.
- Only personnel with particular knowledge and experience with pneumatics may carry out work on pneumatic equipment.
- Only personnel with particular knowledge and experience in gas equipment may carry out work on gas equipment.

A



SAFETY PRECAUTIONS

Transportation instructions

- Parts which need to be dismantled for transport purposes must be carefully replaced and secured before taking into operation.
- The transport may only be carried out by trained personnel.
- For transportation, only use lifting devices and equipment with sufficient lifting power.
- Do not stand or work under suspended loads.
- Also separate from minor relocation machinery / system of any external energy supply. Before recommissioning, reconnect the machine to the mains according to regulations.
- When recommissioning, proceed according to the operating instructions..

Safety regulations

- Inspections according to legal and local obligatory regulations regarding accident prevention are carried out by the manufacturer or by authorised expert personnel. No guarantees whatsoever are valid for damage caused or favoured by the non-consideration of these directions for use.

A



A

INSTALLATION

INSTALLATION

Installation in closed rooms



Danger

No operation in explosion-hazard areas.
The unit is not approved for operation in areas prone to explosion.

For installation in closed rooms, observe the following:

- Install the unit horizontally and level. The floor must be vibration-free and capable of taking the load of the system weight.
- The compressor room must be clean, dry, dust free and as cool as possible. Avoid direct exposure to sunlight. If possible, install unit in such a manner that the compressor fan can intake fresh air from outside. Ensure adequate ventilation and exhaust air opening.
- When locating the compressor in rooms of less than 30 m³ space where natural ventilation is not ensured or other systems having high radiation are operating in the same room, measures must be taken to provide artificial ventilation.
- Intake air must be free from noxious gas e.g. smoke, solvent vapours, exhaust fumes etc.
- Observe the specified operating temperature (see "Technical Data")!



Hinweis

- Intake air must be free from noxious gas e.g. smoke, solvent vapours and exhaust fumes. We recommend not to use the intake air inside the compressor housing. An intake hose would be recommendable!

Approximate value - Diameter of intake hose depending on the length of the intake hose

| Pos. | Length of Intake Hose [m] | Diameter of Intake Hose [mm] |
|------|---------------------------|------------------------------|
| 1 | ≤ 03 | Ø 30 |
| 2 | ≤ 10 | Ø 80 |
| 3 | ≤ 15 | Ø 100 |
| 4 | ≤ 20 | Ø 120 |

INSTALLATION

Dimensions

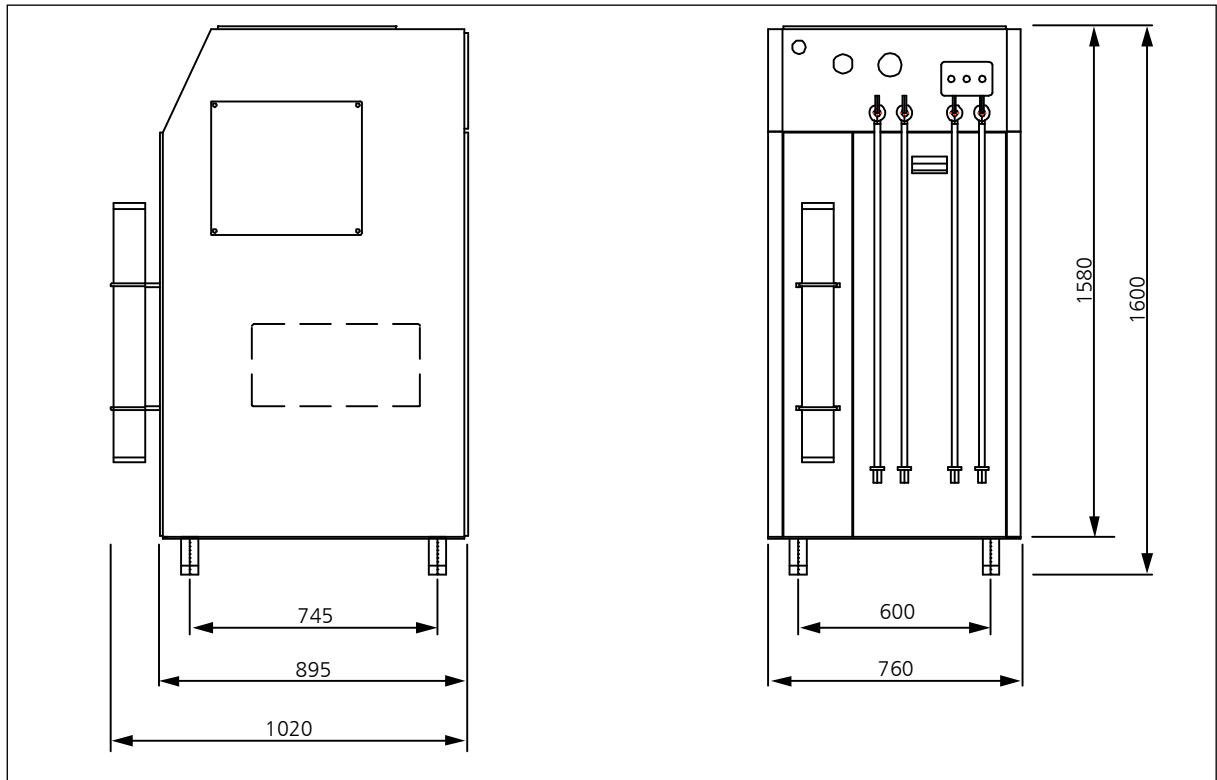

Fig. Dimensions

A

INSTALLATION

Minimum distances



Note

Minimum distances must be adhered!

- Make sure that the compressor always has a sufficient amount of fresh air available.
- To prevent serious damage, ensure that the cooling air flow can flow freely.
- The following minimum distances must be adhered:
Front side min. 1500 mm, sides and rear side min. 500 mm, distance to the ceiling min. 500 mm.
Avoid anything in this area which can restrict the cooling air flow.

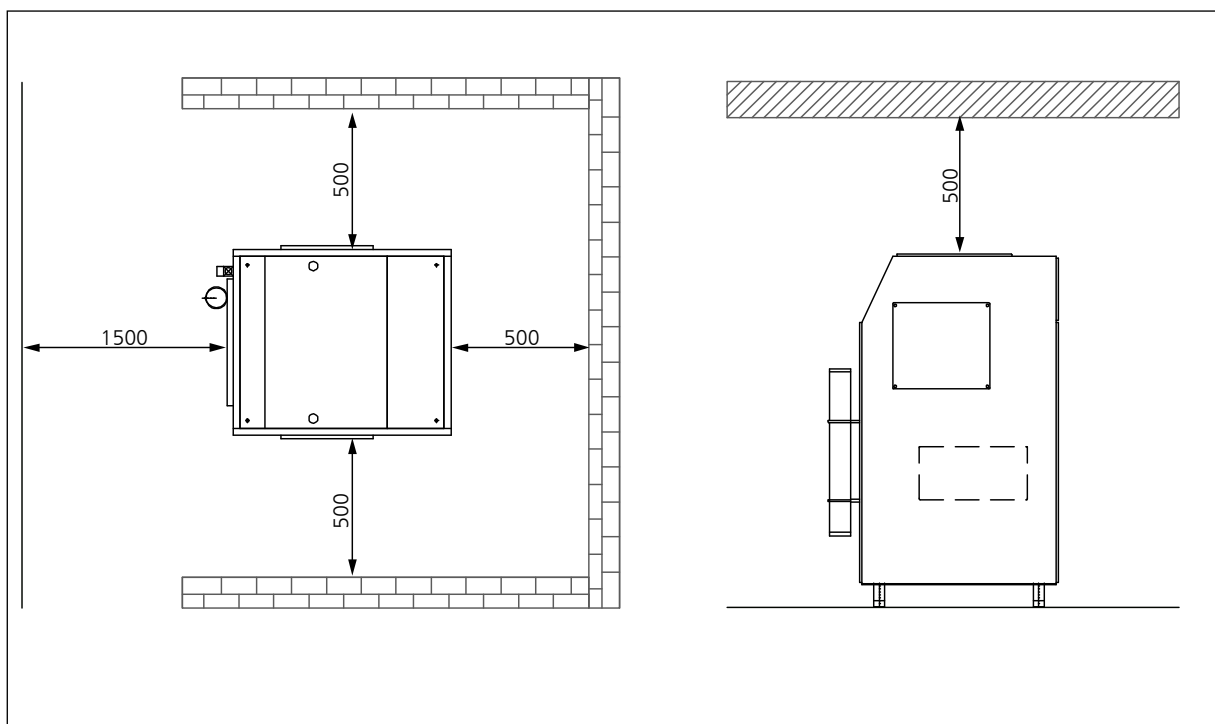

Fig. Minimum distances

INSTALLATION

Ventilation

- Make sure that the compressor always has a sufficient amount of fresh air available for cooling.
- To prevent serious damage, ensure that the cooling air flow can flow freely.
- The necessary cooling air flow can be calculated by using the following formula:
 $300 \times \text{drive power [kW]} = \text{required cooling air flow [m}^3/\text{h]}$
 Example 11kW motor: $300 \times 11\text{kW} = 3300 \text{ m}^3/\text{h} = \text{required cooling air flow.}$
- The fan capacity for fresh air and warm air must meet at least the required cooling air flow.
 The fans must have the same capacity.

A

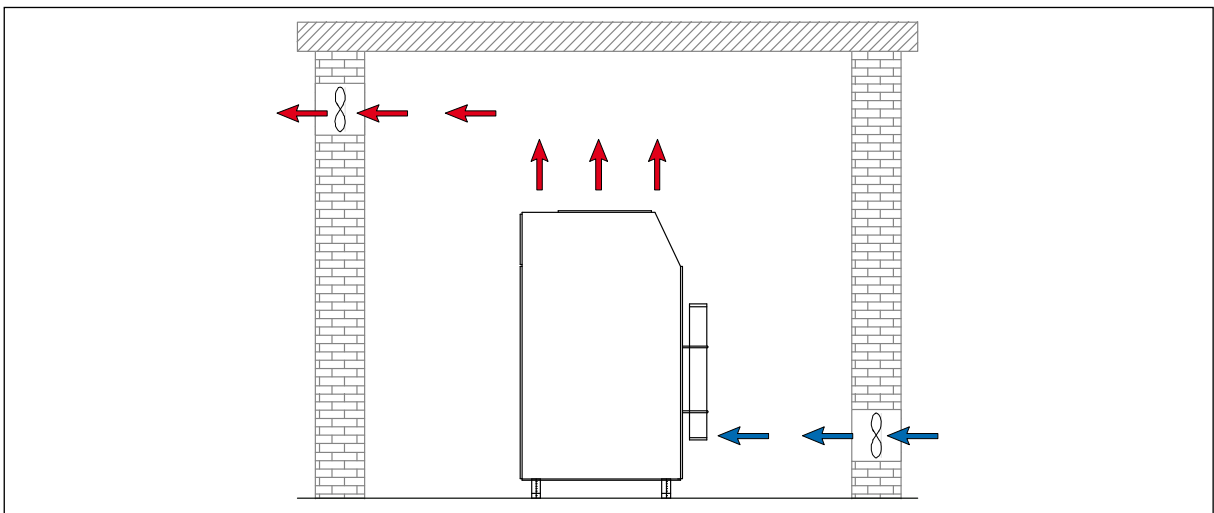

Fig. Ventilation through facade

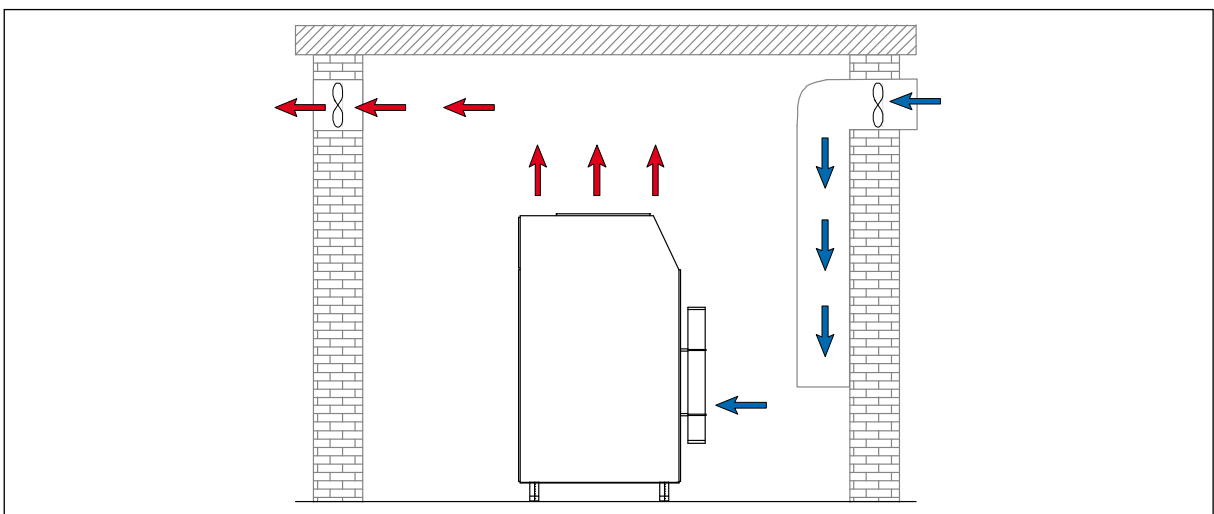

Fig. Ventilation via ventilation stack

INSTALLATION

Electrical Installation



Warning

Work on the electrical equipment on / with the machine / unit may only be carried out by qualified electricians.

For installation of electrical equipment, observe the following:

- If control devices are delivered by the factory, refer to the appropriate wiring diagram.
- Ensure correct installation of protective conductors.
- Check conformity of motor and control device tension and frequency with those of the electric network (see name plate on the compressor).
- The fusing should be done in accordance with the valid regulations of the responsible electricity supply company.
- When connecting the unit to the electrical supply, check the compressor direction of rotation (see chapter "Maintenance" -> Check turning direction).
- Fuse the motor correctly (see table; use slow-blow fuses).

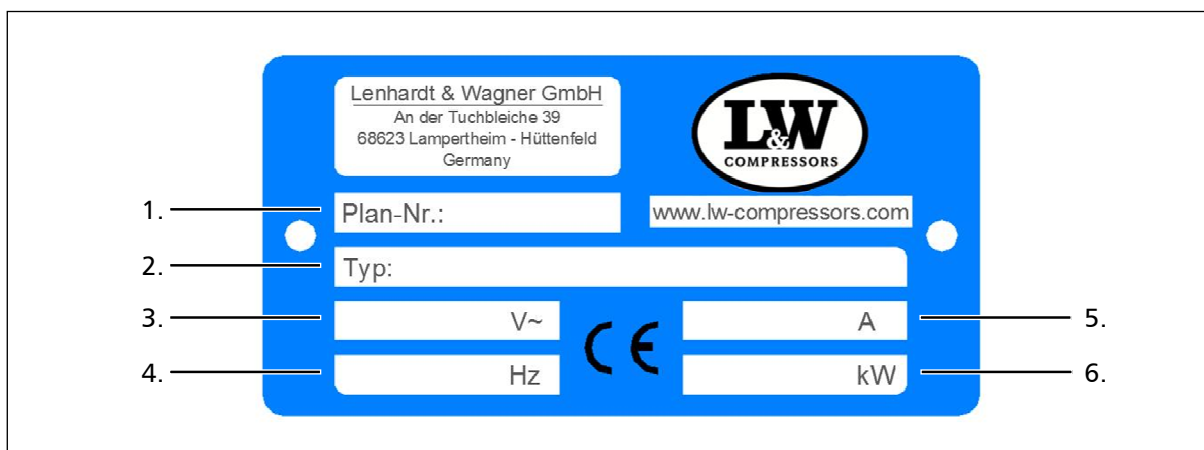

Fig. Compressor name plate

| No. | Designation |
|-----|---------------------------|
| 1. | Circuit diagram number |
| 2. | Compressor type |
| 3. | Power supply |
| 4. | Frequency |
| 5. | Motor current consumption |
| 6. | Nominal motor power |

INSTALLATION

Electrical Installation

The standard compressor version is prepared for the connection to three phases (brown, black, grey), neutral conductor (blue) and protective earth conductor (green/yellow).

Fig. - Connection to the switch box

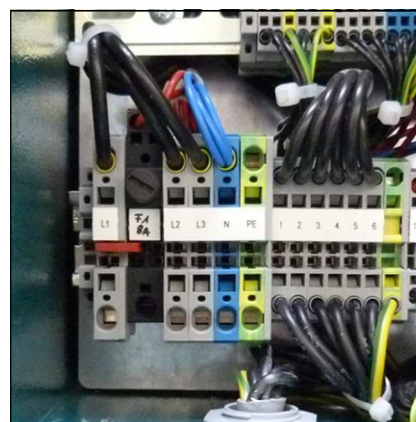

A

Recommended fuses for 360 - 500 V operating voltage

| Nominal motor power | | Fusing start A | | Connection in mm ² | |
|---------------------|------|----------------|------------|-------------------------------|-----------|
| [kw] | [A] | Direct | Star/Delta | Contactor supply | Motor S/D |
| 2.2 | 5 | 10 | - | 1.5 | 1.5 |
| 4 | 8.5 | 20 | - | 2.5 | 1.5 |
| 5.5 | 11.3 | 25 | 20 | 2.5 | 1.5 |
| 7.5 | 15.2 | 30 | 25 | 2.5 | 1.5 |
| 11 | 21.7 | - | 35 | 4 | 2.5 |
| 15 | 29.9 | - | 35 | 6 | 4 |
| 18.5 | 36 | - | 50 | 6 | 4 |
| 22 | 41 | - | 50 | 10 | 4 |
| 30 | 55 | - | 63 | 10 | 6 |

Recommended fuses for 220 - 240 V operating voltage

| Nominal motor power | | Fusing start A | | Connection in mm ² | |
|---------------------|------|----------------|------------|-------------------------------|-----------|
| [kw] | [A] | Direct | Star/Delta | Contactor supply | Motor S/D |
| 2.2 | 8.7 | 20 | - | 1.5 | 1.5 |
| 4 | 14.8 | 25 | - | 2.5 | 1.5 |
| 5.5 | 19.6 | 35 | 25 | 4 | 2.5 |
| 7.5 | 26.4 | 50 | 35 | 6 | 4 |
| 11 | 38 | - | 50 | 6 | 4 |
| 15 | 51 | - | 63 | 10 | 4 |
| 18.5 | 63 | - | 80 | 16 | 6 |
| 22 | 71 | - | 80 | 16 | 6 |
| 30 | 96 | - | 125 | 25 | 10 |



A

OPERATION



OPERATION

Important operation instructions



Note

Ensure that all persons handling the compressor are familiar with function and operation of the unit.



Wear hearing protection

When working on a running machine, always wear hearing protection.

A

FIRST COMMISSIONING

Prior to first commissioning, observe the following:

Necessary steps are described on the next page.

- Ensure that cooling air can flow freely.
- Check compressor oil level with the oil dipstick (see next page).
- Check all connections and retighten if necessary.
- Check if the filter cartridge is in place (see "Service and Maintenance").
- Check the V-belt tension (see next page).
- Check if all filling valves are closed. Open one filling valve and hold tight manually!

Start the compressor

1. Start the compressor by pushing the ON button.
2. Check turning direction - see the rotary direction arrow on the housing of the electric motor (see next pages). If the turning direction is wrong, immediately stop the compressor by pushing the OFF button and contact an authorised electrician.



Warning

Wrong impeller rotation direction!

Immediately after switching the compressor on, check the rotation direction. Depending on the place of installation, the phase sequence can influence the rotation direction.

3. Check oil pressure (if oil pressure gauge is installed).
4. Run the compressor for about 2 minutes.
5. Close the open filling valve carefully.
6. Run the compressor up to maximum pressure and check if the final pressure switch shuts off the compressor. If the final pressure switch does not shut off, switch off the compressor with the OFF button (see chapter "REMEDYING FAULTS").
7. Check the compressor unit for leaks (see "SERVICE AND MAINTENANCE")
8. Now check the condensate drain valves:
 - Fix the black condensate hoses
 - Drain test - press the test button
 - If correct, air escapes
9. Stop the compressor by pushing the OFF button.
10. Open all filling valves carefully to vent.

FIRST COMMISSIONING

Check oil level



Warning

Check oil level daily. Never start the compressor with a too low oil level. Risk of accidental loss, destruction or deterioration.

Check the oil level before each operation of the unit by using the oil dipstick.

Oil level check as follows:

- Unscrew oil dipstick
- Wipe off oil residues
- Insert the oil dipstick back into its tube and screw it until stop
- Unscrew oil dipstick again

The oil level should be between the notch and the end of the oil dipstick. If there is no oil between the notch and the end of the oil dipstick, refill immediately new full synthetic compressor oil.



Oil dipstick

Check V-belt tension

The V-belts could lose tension during transportation. Please check the V-belt tension before starting the compressor.

Tension V-belts / Correct V-belt tension

See chapter "Service and Maintenance" -> "Tension V-belts"

FIRST COMMISSIONING

Check turning direction



Warning

Wrong impeller rotation direction!

Immediately after switching the compressor on, check rotation direction. Depending on the place of installation, the phase sequence can influence the rotation direction.

Before starting the compressor for the first time, check rotation direction (see the rotary direction arrow on the housing of the electric motor).

If the direction of rotation is wrong, the guide pistons of the 2nd and 3rd stages can not be sufficiently lubricated, with the consequence that the pistons will be damaged. Furthermore, cooling air flow will not be sufficient.

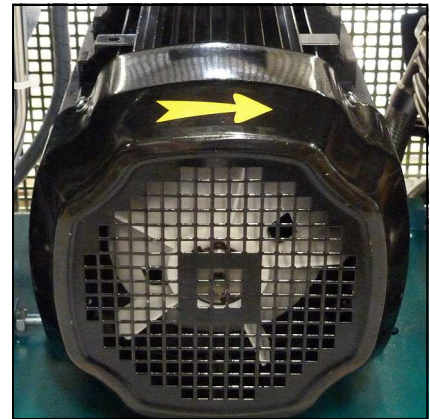

Rotation direction arrow

A



DAILY COMMISSIONING

Prior to daily operation observe the following:

- Ensure cooling air can flow freely.
- Check compressor oil level by the oil sight glass.
- Check if filter cartridge is in place / observe filter cartridge life!
- Ensure toxic-free, pure intake air.

A

OPERATION

Filling procedure



Caution! Fill only cylinders which:

- are marked with the test mark and the test stamp of the expert.
- have been hydrostatic tested (check last test date).
- are rated for the final pressure.
- are free from humidity.



Note

The unit shuts down when final pressure is reached. Thus, the unit always has to be restarted manually.

1. Close all filling valves.
2. Connect the closed compressed air cylinders.
3. Open cylinder valves.
4. Start compressor by pushing the ON button.
5. When the filling pressure gauge increases, open the filling valves slowly.
6. Fill compressed air cylinders to the desired pressure, subsequently close the filling valves slowly.
7. Close and vent all filling valves.
8. Disconnect all compressed air cylinders from filling valves.

A



OPERATION

Switch off the compressor

The compressor unit is equipped as standard with a pressure switch which automatically shuts down the system when the corresponding final pressure is reached.

During filling process, you can shut down the system at any time by pushing the red button (OFF) or the emergency stop (only in case of emergency!).



Note

After automatic or manual switching off, all pressure vessels and filter housings of the compressor will be automatically vented.

A



A

REMEDYING FAULTS

REMEDYING FAULTS

Final pressure can not be reached

| Cause of fault | Remedy |
|---|---|
| Connections leaky | Retighten or clean/replace if necessary |
| Final pressure safety valve leaky | Replace |
| Pipes / heat exchanger broken | Replace |
| Condensate drain valves leaky | Unscrew valves, check sealing surfaces, clean, replace if necessary |
| Final pressure switch stop unit | Verify settings, replace if necessary |
| Piston of pneumatic condensate valve sticks | Clean pneumatic condensate valve and restore function, check/replace o-rings, replace valve completely if necessary |

Strong compressor vibration

| Cause of fault | Remedy |
|---------------------------------------|---------------------------------|
| V-belt tension too loose | Tension V-belt |
| Drive motor / Compressor unit loosely | Retighten mounting screws |
| Anti vibration mounts used up | Replace |
| Ground not levelled | Ensure a solid and level ground |

Air supply too low

| Cause of fault | Remedy |
|--|---|
| Inlet and outlet valves contaminated / defective | Clean, replace if necessary |
| Cylinder(s), piston(s) or piston ring(s) used up | Replace |
| V-belt slips | Tension V-belt |
| See chapter "Final pressure can not be reached" | See chapter "Final pressure can not be reached" |



REMEDYING FAULTS

A

Compressor overheated

| Cause of fault | Remedy |
|--|---|
| Inlet filter cartridge contaminated | Replace |
| Ambient temperature too high | Improve room ventilation / |
| Cooling air inlet and outlet insufficient | Observe minimum distances (see Installation Instructions) |
| Air intake hose too long | Reduce length of the air intake hose |
| Air intake hose diameter too small | Use a larger diameter |
| Wrong compressor rotation direction | Ensure correct phase rotation, |
| Inlet and outlet valves contaminated / defective | Clean, replace if necessary |

Safety valve leaks

| Cause of fault | Remedy |
|---|-----------------------------|
| Inlet and outlet valves of the following pressure stage defective | Clean, replace if necessary |
| Sinter filter of the following water separator blocked | Replace |
| Safety valve leaky | Replace |

Oil taste in the air

| Cause of fault | Remedy |
|--|----------------------------|
| Mole carbon filter cartridge saturated | Replace |
| Compressor oil unsuitable | Use prescribed oil quality |
| Filter cartridge unsuitable | Use prescribed filter type |
| Cylinder(s), piston(s) or piston ring(s) defective | Replace |

REMEDYING FAULTS

Automatic condensate drain defective

| Cause of fault | Remedy |
|---|---|
| Solenoid coils defective | Replace |
| Cable / supply cable defective | Repair, replace if necessary |
| Timer / relais defective | Replace |
| Sinter filter of pneumatic condensate valve blocked | Replace |
| Piston of pneumatic condensate valve sticks | Clean pneumatic condensate valve and restore function, check/replace o-rings, replace valve complete if necessary |

Condensate drain starts before reaching final pressure

| Cause of fault | Remedy |
|---|---|
| Pressure stages are not as prescribed, control pressure of pneumatic condensate valve too low | Check corresponding inlet and outlet valve, replace if necessary. |
| Piston sealing of pneumatic condensate valve contaminated / used up | Clean, replace if necessary |
| Timer / relais settings not correct | Adjust as prescribed |
| Timer / relais defective | Replace |

Compressor stops before final pressure

| Cause of fault | Remedy |
|---|---|
| Final pressure switch settings not correct | Correct settings |
| Opening pressure of the pressure maintaining valve too high | Correct settings |
| Fuse / circuit breaker has tripped Valid only for E models | Check fusing of the power supply / observe regulations |
| Emergency stop switch has tripped | Unlock emergency stop switch, close compressor housing door correctly |



REMEDYING FAULTS

Filter life not sufficient

| Cause of fault | Remedy |
|--|--|
| Pressure maintaining valve settings not correct | Adjust as prescribed |
| Filter cartridge unsuitable | Replace by a prescribed filter cartridge type |
| Filter cartridge too old | Observe expiration date |
| Filter cartridge packaging incorrect / damaged / already opened. Filter cartridge already partly saturated before change | Store filter cartridges properly, dispose defective cartridges |
| Operating temperature too high | Ensure sufficient ventilation |
| Cylinder(s), piston(s) or piston ring(s) defective | Replace |

Oil consumption too high

| Cause of fault | Remedy |
|--|---|
| Cylinder(s), piston(s) or piston ring(s) defective | Replace |
| Compressor oil unsuitable | Use prescribed oil quality |
| Operating temperature too high | Observe prescribed operating temperatures |
| Oil leak at the compressor block | Tighten corresponding mounting screws, if necessary replace corresponding paper sealing / o-ring / shaft seal |



A

MAINTENANCE AND SERVICE

MAINTENANCE AND SERVICE

Service, Repair and Maintenance

Carry out service and maintenance work exclusively when the compressor is stopped and depressurised. The unit should be leak-checked regularly. Leaks can be preferably localised by using a leak detector spray (if necessary, brush pipes with soapy water).

We recommend that only authorised L&W service technicians carry out service work on the bearing of the compressor (crankshaft and connecting rods).

We urgently recommend that all maintenance, repair and installation work must only be carried out by trained personnel. This is necessary because all maintenance work can not be explained exactly and detailed in this manual.

Only use authentic spare parts for service work.



Danger

Components under pressure, such as hose ends, can quickly come loose when manipulated and can cause potentially fatal injuries due to the pressure surge. Any work on system parts may only be performed in a pressure-compensated state.



Warning

The use of accessories that have not been tested can lead to death or serious injury or damage to the unit. Only use authentic spare parts for service work.



Warning

Carry out maintenance or service work when the unit is switched off and protected against unexpected restart.



Warning

Risk of burns!

Carry out maintenance or service work when the unit has cooled down.



MAINTENANCE AND SERVICE

Daily before taking unit into operation

| Maintenance work | Type | Quantity | Order No. |
|--|------|----------|-----------|
| Check oil level | - | - | 000001 |
| Check condition of all filling hoses | - | - | - |
| Check filter cartridge lifetime | - | - | - |
| Operate unit to final pressure and check function of final pressure switch | - | - | - |

At 25 operation hours

| Maintenance work | Type | Quantity | Order No. |
|------------------|------|----------|-----------|
| Oil change | - | 1,8 | 000001 |

Every 3 months or as required

| Maintenance work | Type | Quantity | Order No. |
|---|------|----------|-----------|
| Check automatic condensate drain, open manual condensate taps | - | - | - |
| Check/Retorque all connections and bolts | - | - | - |



MAINTENANCE AND SERVICE

Annually

| Maintenance work | Type | Quantity | Order No. |
|---|------|----------|-----------|
| Oil change, if less than 1000 operating hours | - | 1.8 | 000001 |
| Check opening pressure of final safety valve | - | - | - |
| Clean coolers | - | - | - |
| Clean all oil/water separators, if less than 500 operating hours | - | - | - |
| Service intake filter (depends on condition - if less than 500 operating hours) | - | - | - |
| Clean oil filter element, if less than 1000 operating hours | - | - | - |
| Check all connections for leakage | - | - | - |

Every 500 operating hours

| Maintenance work | Type | Quantity | Order No. |
|---|------|----------|-----------|
| Change intake filter | - | 1 | 000170 |
| Check pressure maintaining/non-return valve | - | - | - |
| Check V-belt tension and condition | - | - | - |



MAINTENANCE AND SERVICE

Every 1000 operating hours

A

| Maintenance work | Type | Quantity | Order No. |
|---|-------------------|----------|-----------|
| Replace V-belt | LW 230 ES (50Hz) | 2 | 003763 |
| | LW 230 ES (60Hz) | 2 | 003694 |
| | LW 280 ES (50Hz) | 2 | 001684 |
| | LW 280 ES (60Hz) | 2 | 003763 |
| | LW 320 ES (50Hz) | 2 | 001684 |
| | LW 320 ES (60Hz) | 2 | 003763 |
| Replace sintered metal filter element of water separators | 1st and 2nd stage | 2 | 002123 |
| Replace o-rings of water separators | 1st and 2nd stage | 2 | 001255 |
| Replace o-ring of oil separator | - | 1 | 001294 |
| Replace silencer | - | 1 | 000178 |
| Replace sintered metal filter of oil separators | - | 1 | 000184 |
| Replace sintered metal filter of pneumatic condensate valve | - | 1 | 000188 |
| Replace o-rings of the final filter housing | - | 2 | 001287 |
| Replace back-up rings of the final filter housing | - | 2 | 001285 |
| Replace sintered metal filter of oil filter | - | 1 | 000184 |
| Replace o-ring of oil filter | - | 1 | 000435 |
| Oil change | - | 1.8 | 000001 |



MAINTENANCE AND SERVICE

Every 2000 operating hours

| Maintenance work | Type | Quantity | Order No. |
|---|------------------|----------|-----------|
| Replace all inlet and outlet valves incl. Gaskets | 1st stage | 1 | 002093 |
| | 2nd stage | 1 | 000542 |
| | 3rd stage | 1 | 000543 |
| | Upper gasket 1st | 1 | 000257 |
| | Lower gasket 1st | 1 | 000258 |

A

MAINTENANCE AND SERVICE

Service Kits

The service kits contain parts for maintenance according to the factory requirements.

The use of the service kits ensures that all required parts are ordered and replaced and gives assurance that all parts are included in the order. Depending on the model and interval, the service kits include parts such as O-Rings, Sinter Filter, Inlet Filter, V-Belts, Silencers, In-&Outlet Valve, Valve Seals and Compressor oil.



Servicekit

A

Service Kits LW 230 ES / LW 280 ES / LW 320 ES for 50 Hz

| Compressor | Frequency | Operating Hours | Order No. |
|------------|-----------|-----------------|-----------|
| LW 230 ES | 50 Hz | 1000 h | 006749 |
| LW 230 ES | 50 Hz | 2000 h | 006750 |
| LW 280 ES | 50 Hz | 1000 h | 004970 |
| LW 280 ES | 50 Hz | 2000 h | 003920 |
| LW 320 ES | 50 Hz | 1000 h | 004970 |
| LW 320 ES | 50 Hz | 2000 h | 003920 |

Service Kits LW 230 ES / LW 280 ES / LW 320 ES for 60 Hz

| Compressor | Frequency | Operating Hours | Order No. |
|------------|-----------|-----------------|-----------|
| LW 230 ES | 60 Hz | 1000 h | 004656 |
| LW 230 ES | 60 Hz | 2000 h | 005168 |
| LW 280 ES | 60 Hz | 1000 h | 006749 |
| LW 280 ES | 60 Hz | 2000 h | 006750 |
| LW 320 ES | 60 Hz | 1000 h | 006749 |
| LW 320 ES | 60 Hz | 2000 h | 006750 |

MAINTENANCE AND SERVICE

Tension V-belts

Tension V-belt as follows:

- Loosen mounting screws (Fig. 1)
- Loosen conternut (Fig. 2)
- Tighten V-belt by the hexagon head screw (Abb. 3)
- Tighten conternut (Fig. 2)
- Tighten mounting screws (Fig. 1)

ATTENTION:

Motor plate (A) and motor (B) must be flush mount (Fig. 4)



Fig. 1 - Loosen mounting screws

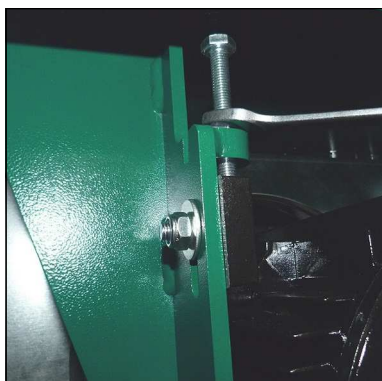

Fig. 2 - Loosen conternut

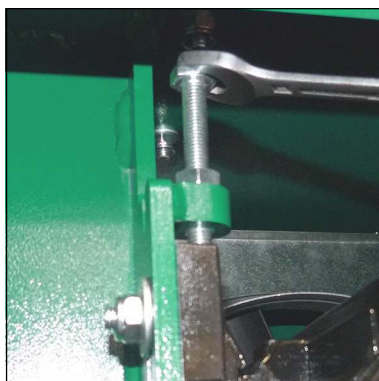

Fig. 3 - Tighten V-belt by the hexagon head screw

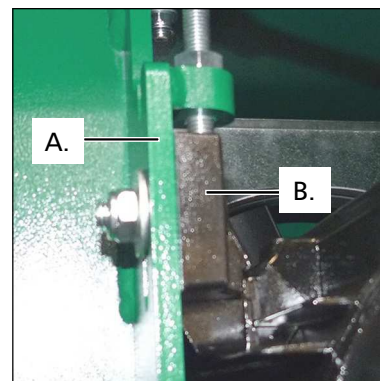

Fig. 4 - Motor plate and motor must be flush mount

Correct V-belt tension

Do not tension V-belts too tight. This damages bearings of compressor and motor. The V-belts should only be tensioned until there is no noise caused by slipping during start.

Settings

| Motor Type | Initial Installation | Operation after running in |
|----------------------|----------------------|----------------------------|
| Electric motors 50Hz | 500 N | 400 N |
| Electric motors 60Hz | 400 N | 300 N |

Check oil level



Warning

Check oil level daily. Never start the compressor with a too low oil level. Risk of accidental loss, destruction or deterioration.

Check the oil level before each operation of the unit by using the oil dipstick.

Oil level check as follows:

- Unscrew oil dipstick
- Wipe off oil residues
- Insert the oil dipstick back into its tube and screw it until stop
- Unscrew oil dipstick again

The oil level should be between the notch and the end of the oil dipstick. If there is no oil between the notch and the end of the oil dipstick, refill immediately new full synthetic compressor oil.



Oil dipstick

Oil change



Note

We recommend oil change at least once a year - depending on total operating hours.

A

Oil change as follows:

- Run compressor warm for approx. 2 min.
- Switch off and vent compressor.
- Place a suitable oil drain tray under the drain hose.
- Open carefully oil drain valve and drain oil completely.
- Close oil drain valve.
- Loosen oil fill port with an appropriate adjustable wrench (AF 0-40 mm) and unscrew manually.
- Fill oil by using a funnel.
- Check oil level. The oil level should be between the middle and upper end of the oil sight glass.
- Screw oil fill port manually in and tighten with the adjustable wrench.

The oil change is now completed.

Maintenance intervals

- First oil change after 25 operating hours (total hours).
- All further changes after each 1,000 operating hours.

Oil and oil capacity

Approx. 1800 ml synthetic compressor oil is necessary for one oil change. Only use synthetic compressor oil which is recommended as suitable from L&W.

Oil filter maintenance



Caution

Oil filter housing is filled with oil. Take all necessary protection measures.



Note

Clean all parts thoroughly before assembly.

Oil filter maintenance as follows:

- Loosen pipe connections
- Loosen mounting screws (Fig. 1) and remove oil filter
- Loosen mounting screws of the filter cover (Fig. 2).
- Change o-ring, previously grease new o-ring (Fig. 3)
- Loosen mounting nuts and remove filter washer (Fig. 4)
- Change sinter filter (Fig. 4).
- Place filter washer and washer (Fig. 5) and tighten nut.
- Place filter cover, fix and tighten mounting screws of the filter cover (Fig. 2).
- Screw and tighten mounting screws of the oil filter (Fig. 1).
- Connect pipe connections and tighten.

The oil filter maintenance is now completed.



Fig. 1 - Loosen mounting screws

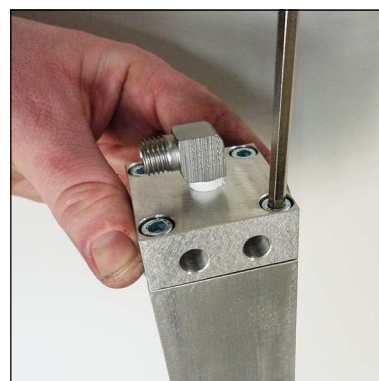

Fig. 2 - Loosen mounting screws of the filter cover

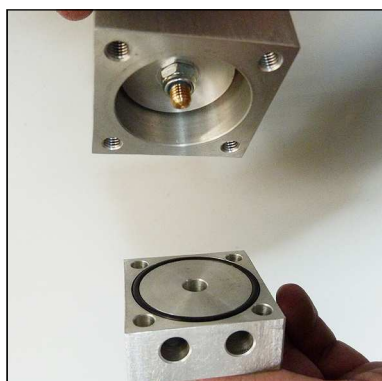

Fig. 3 - Change o-ring

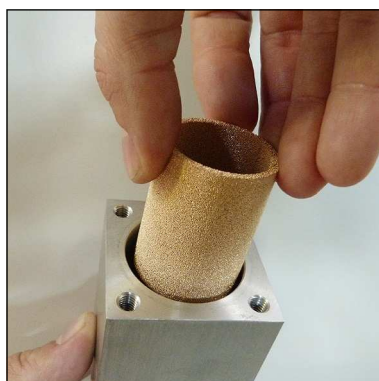

Fig. 4 - Change sinter filter



Fig. 5 - Place filter washer and washer

Final pressure switch



Note

Do not adjust the final pressure switch to the safety valve pressure. The final pressure switch has to be adjusted to min. 10 bar below the safety valve pressure. Otherwise, the safety valve can open during operation. This considerably reduces the life of the safety valve.

The pressure switch shuts off the compressor automatically when the selected final pressure is reached. The final pressure switch is already adjusted to the corresponding cut-out pressure.

The pressure can be adjusted with the upper adjusting screw as follows:

Increasing cut-out pressure:

Turn the adjusting screw clockwise

Reducing cut-out pressure:

Turn the adjusting screw anti-clockwise

Adjust the pressure switch in steps of a quarter turn. Restart the compressor after every adjustment step to verify the actual cut-out pressure.

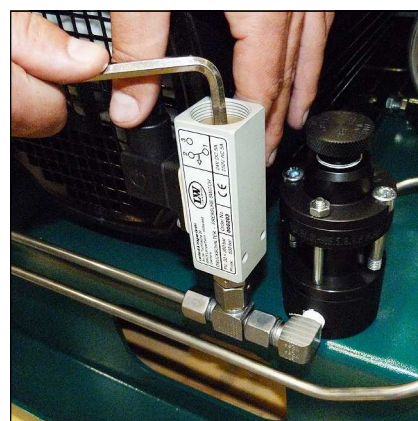

Final pressure switch

Example settings:

| Safety valve | Max. Operating Pressure |
|--------------|-------------------------|
| 225 bar | 215 bar |
| 250 bar | 240 bar |
| 330 bar | 320 bar |

Automatic condensation dump system



Note

The collected condensate can contain oil and has to be disposed according to regulations.

The compressor comes as standard with an automatic condensation dump system. Solenoids drain all condensate separators every 15 minutes.

To test the system, press the blue condensate test drain button on the operating panel.

Oil / water separators

Condensate is separated after every stage of compression. All three oil / water separators are equipped with electronic timer controlled solenoids. The timer is located in the switch box and activates the dump valves about every 15 minutes.

To release the complete condensate through the black plastic hoses, we recommend using an 20 l container at least.

The drain noise can be kept to a minimum by using a silencer.

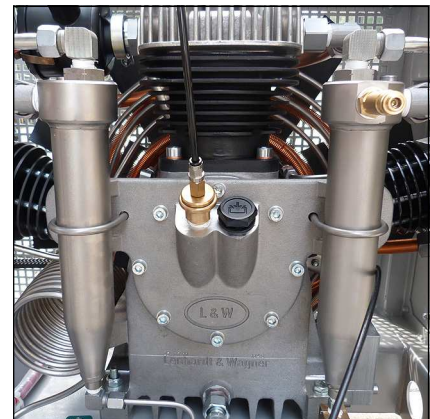

Oil / water separators 1st and 2nd stage

Maintenance intervals

We recommend to clean oil and water separators every 500 operating hours or at least once a year, to check for corrosion damage and to replace o-rings if necessary.

All oil / water separators have an integrated sinter filter which has to be replaced every 1,000 operating hours.



Oil / water separators final stage

Oil / Water separators 1st and 2nd stage - Maintenance



Note

Clean all parts thoroughly before assembly.

Maintain oil / water separators 1st and 2nd stage as follows:

- Loosen pipe connections (Fig. 1)
- Loosen screw connection at the water separator (sinter filter holder)
- Remove sinter filter holder (Fig. 2).
- Change sinter filter (Fig. 3), screw-in new sinter filter by using a suitable screwdriver.
- Change o-ring, previously grease new o-ring (Fig. 4)
- Place sinter filter holder into the water separator and tighten
- Connect pipe connections and tighten.

The oil / water separator maintenance is now completed.

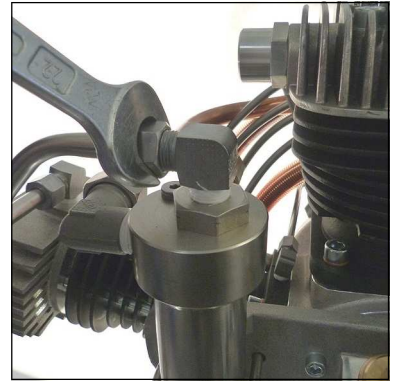

Fig. 1 - Loosen pipe connections

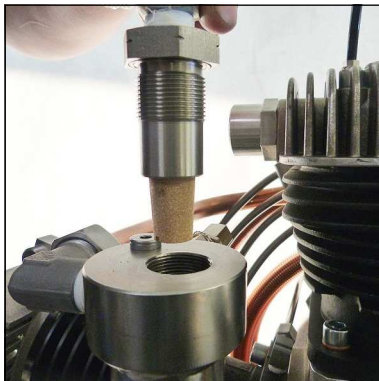

Fig. 2 - Remove sinter filter holder



Fig. 3 - Change sinter filter



Fig. 4 - Change o-ring

MAINTENANCE AND SERVICE

Oil / water separators final stage - maintenance



Note

Clean all parts thoroughly before assembly.

Change/clean oil / water separators final stage as follows:

- Loosen pipe connections and mounting screws.
- Remove oil / water separators.
- Open ring nut and remove separator top (Fig. 1).
- Loosen nut at the separator top.
- Change sinter filter (Fig. 2).
- Reassemble all parts and tighten nut.
- Change o-ring, previously grease new o-ring (Fig. 3).
- Place separator top and tighten ring nut manually.
- Replace silencer.
- Mount oil / water separators.
- Tighten pipe connections and mounting screws.

The oil / water separator maintenance is now completed.



Oil / water separators final stage



Fig. 1 - Loosen ring nut

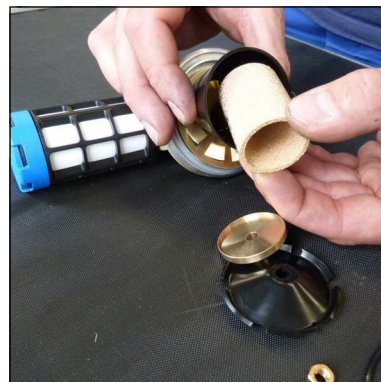

Fig. 2 - Change sinter filter

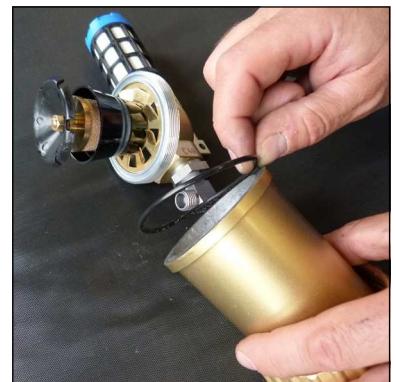

Fig. 3 - Change o-ring

Pneumatic condensate valve - maintenance



Note

Clean all parts thoroughly before assembly.

Pneumatic condensate valve change as follows:

- Loosen pipe connections and mounting screws.
- Remove pneumatic condensate valve.
- Loosen connection (Fig. 2).
- Change sinter filter (Fig. 3).
- Tighten horizontal screw.
- Mount pneumatic condensate valve.
- Tighten pipe connections and mounting screws.

Pneumatic condensate valve maintenance is now completed.

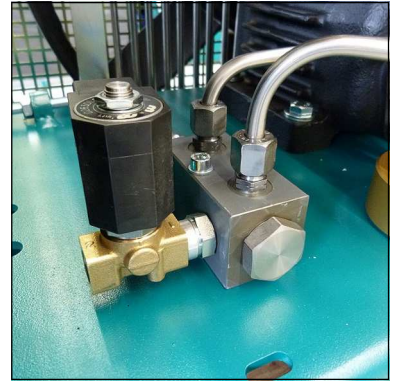

Pneumatic Condensate Valve

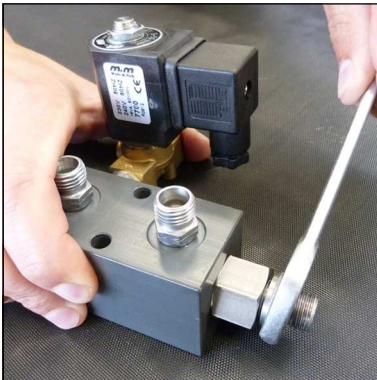

Fig. 2 - Loosen connection

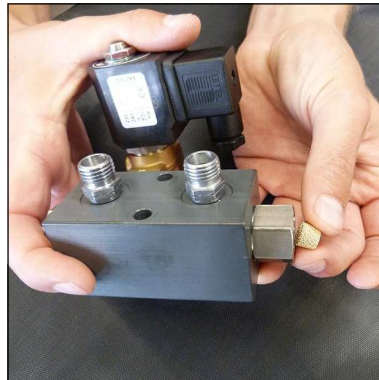

Fig. 3 - Change sinter filter

MAINTENANCE AND SERVICE

Filter housing

The mole carbon filter housing is installed on the right hand side of the compressor housing.

Inside the filter housing a jet blows air on to the housing wall. Condensation water and oil are led by centrifugal force to the bottom of the housing. Air flows through the mole carbon filter cartridge, which purifies the air from residual moisture and odours.



Filter housing

Filter cartridge

The high-pressure compressor is equipped with an integrated breathing air purification system. Air is compressed up to 330 bar, dried and odour- and tasteless purified. Oil residues are bounded. The breathing air filter cartridge consists of a molecular sieve and activated-carbon filter.

Cartridge capacity: approx. 1.7 l

All breathing air filter cartridges are factory vacuum sealed.

We recommend unpacking the filter cartridges just before installation. Filter cartridges which are exposed too long could be saturated with moisture and become unusable.

| P/N | Filtering | Models |
|------------------|---|--|
| 000002 000003 | DIN EN 12021 (Breathing Air) | For models with 1.7 ltr Filter housings For models with 2.3 ltr Filter housings |
| 001459 001461 | DIN EN 12021 (Breathing Air) incl. CO/CO ₂ | For models with 1.7 ltr Filter housings For models with 2.3 ltr Filter housings |
| 001466 001467 | Only oil / odour removal (<0,1mg/m ³) | For models with 1.7 ltr Filter housings For models with 2.3 ltr Filter housings |
| 001460 001462 | Only drying (<15mg/m ³) | For models with 1.7 ltr Filter housings For models with 2.3 ltr Filter housings |
| 001468 | CNG filter (drying and oil removal) | For models with 2.3 ltr Filter housings |

Maintenance intervals

Breathing air filter cartridges should be changed at the following intervals, at +20°C or more often, depending on humidity and ambient temperature:

- 72 hours for LW 230 ES
- 54 hours for LW 280 ES
- 46 hours for LW 320 ES

MAINTENANCE AND SERVICE

Filter cartridge change

Filter cartridge change as follows:

- Run the compressor up to a pressure of 100 bar.
- Stop compressor.
- Open filling valve.
- Unscrew filter housing cover by using the special filter tool (Fig. 1).
- Place the T-piece end of the filter tool in the recess of the filter cartridge (Fig. 2).
- Unscrew the filter cartridge anti-clockwise and pull the cartridge out of the housing (Fig. 3).
- Open the packing of the new filter cartridge and place it with the filter tool in the filter housing.
- Screw the new filter cartridge hand tight in by using the filter tool.
- Screw the cover of the filter housing first manually in.
- After it has been completely screwed in, turn cover anticlockwise for 90°. This avoids tightening of the cover due to vibration..

The filter cartridge change is now completed.



Note

Ensure that the old filter cartridge is disposed correctly at an approved waste point.



Fig. 1 - Unscrew the filter housing cover.



Fig. 2 - Place the T-piece end of the filter key in the top of the filter cartridge.



Fig. 3 - Pull the cartridge out of the housing.

A

Filter housing - maintenance



Note

Clean all parts thoroughly before assembly.

Filter housing maintenance as follows:

- Open Filter Cover (Fig. 1).
- Change o-ring and back-up ring, previously grease both (Fig. 2).
- Grease filter cover thread and close.

Dismount filter housing

- Loosen pipe connections and nuts (Fig. 3).
- Remove filter housing.
- Dismount filter housing base.
- Change o-ring and back-up ring, previously grease both (Fig. 4).
- Screw filter base tight in.

Mount filter housing

- Connect pipe connections and tighten.
- Adjust holding clamp and tighten nuts.

The filter housing maintenance is now completed.



Fig. 1 - Open Filter cover

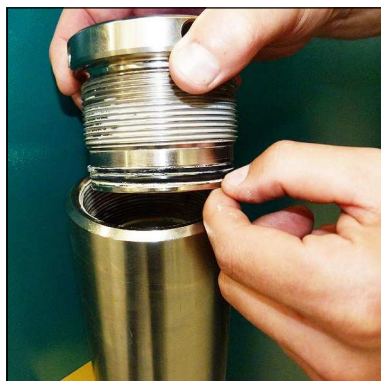

Fig. 2 - Change o-ring and back-up rings

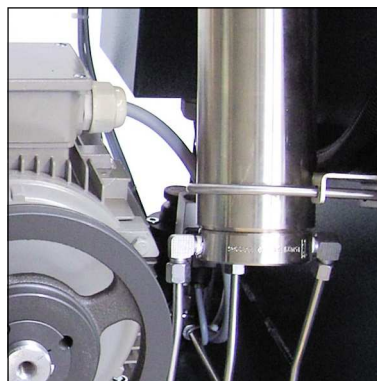

Fig. 3 - Loosen pipe connections and nuts



Fig. 4 - Change o-ring and back-up rings

MAINTENANCE AND SERVICE

Inlet filters



Note

Dirty filters make intaking air difficult and reduce delivery capacity. Risk of compressor overheating.

A micro filter cartridge is used as an air inlet filter. Check air inlet filter regularly or replace it. Defective air inlet filters should be immediately replaced with a corresponding filter.

Maintenance intervals

We recommend that the filter cartridge should be replaced every 500 working hours (depending on pollution grade).

Inlet filter cartridge change

Inlet filter cartridge change as follows:

- Loosen cover by pushing the three clips apart.
- Remove inlet filter cartridge and replace it by a new one.
- Refit cover and snap the three clips until a loud 'click' can be heard.

The inlet filter cartridge change is now completed.

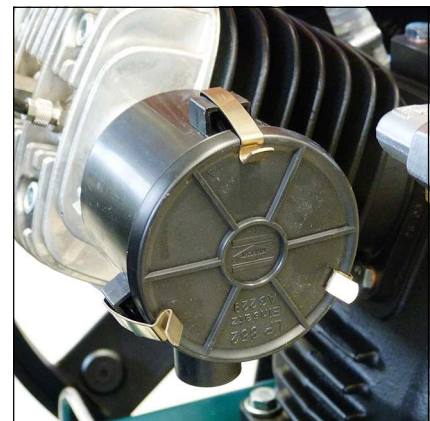

Air filters

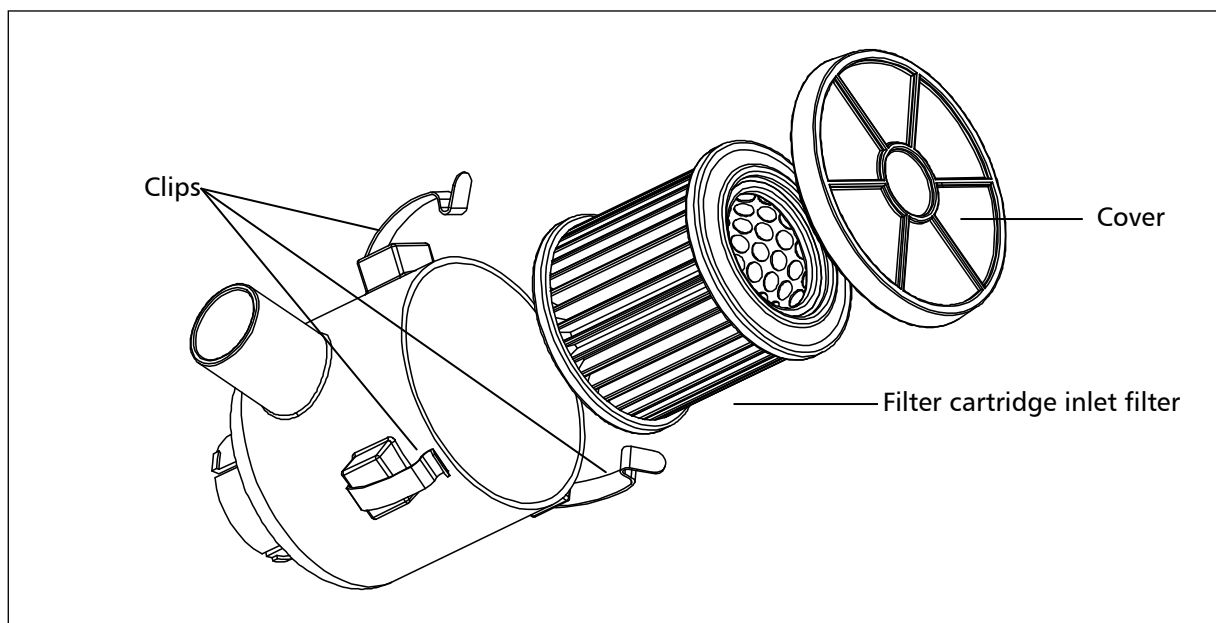

Filter cartridge inlet filter

MAINTENANCE AND SERVICE

Cylinder heads and valves

Inlet and outlet valves of the specific compressor stages are located between valve head and cylinder. Outlet valves open while piston downstroke, inlet valves open while upstroke or compression stroke.

Valves are subject to normal wear and tear and have to be replaced at certain intervals (depending on specific operating conditions). Dismount valve heads to change valves. The three valves are combined inlet and outlet valves. The first stage is a plate valve. The stages two and three are made of a spring operated piston which acts inside a bronze cylinder.



Inlet and outlet valve incl. gaskets of the 3rd stage

Maintenance intervals

All valves should be replaced after 2000 working hours due to normal wear and tear. To replace valves the cylinder heads have to be removed. There are no special tools required to replace these valves.

Available special tools

Special tools are not necessary for dismounting inlet and outlet valves but make work easier.

Order number: 006847



Special tool

Replace inlet and outlet valve 1st stage



Note

The figures of the parts can differ due to the different stages.

Replace the inlet and outlet valve 1st stage as follows:

Remove Inlet / Outlet Valve

- Loosen pipe connections
- Loosen screw connections of the crankcase ventilation hose (Fig. 1)
- Remove hose
- Loosen valve head screws
- Remove valve head
- Pull out inlet and outlet valve (Fig. 2)
- CAUTION: Observe that the lower copper valve ring is also pulled out. It can still stick inside the cylinder (Fig. 3).
- Check valve head if defective

Install Inlet / Outlet Valve - see following page

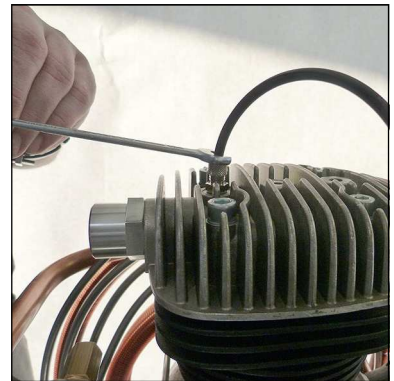

Fig. 1 - Loosen valve head screws



Fig. 2 - Pull out inlet and outlet valve



Fig. 3 - Copper valve ring

Replace inlet and outlet valve 1st stage - continued from previous page



Warning

The exact alignment of upper and lower valve gasket is very important. Inlet and outlet channels have to be exactly centred.

Install Inlet / Outlet Valve

- Grease new lower valve gasket and place into the cylinder.
CAUTION: Ensure the correct mounting position of the copper valve ring (position the burr-free side in direction of the cylinder).
- Place the new inlet and outlet valve on the cylinder and align upper valve gasket (paper gasket) (Fig. 4).
CAUTION: Do not turn the inlet and outlet valve inside the cylinder! The paper gasket could cover inlet channels!
- Refit the valve head and tighten the valve head screws crosswise. (Fig. 5)
- Torques: 1st stage 40 Nm
- Fit crankcase ventilation hose and tighten screw connection
- Connect pipe connections and tighten (Fig. 6).

Inlet and outlet valves change 1st stage is now completed.

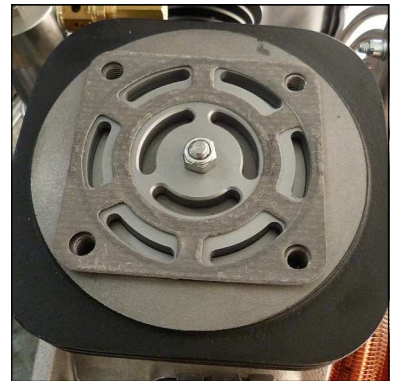

Fig. 4 - Place and align upper valve gasket

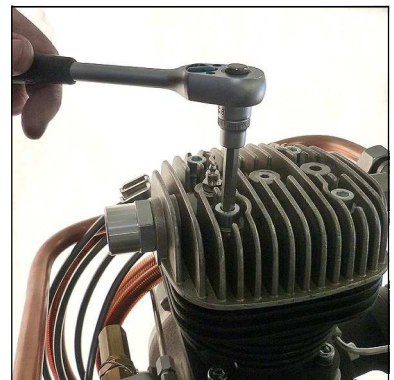

Fig. 5 - Screw valve head screws in



Fig. 6 - Connect pipe connections and tighten

MAINTENANCE AND SERVICE

Replace inlet and outlet valves 2nd and 3rd stage



Note

The figures of the parts can differ due to the different stages.

Inlet and outlet valves change as follows:

- Loosen pipe connections (Fig. 1).
- Loosen valve head screws (Fig. 2).
- Remove lower valve gasket (Fig. 3).
- Dismount inlet and outlet valve (Fig. 4).
Observe that the upper valve gasket is also pulled out. It can still stick inside the cylinder head.
- Check valve head if defective (check centre pin)
- Mount valve gasket on inlet and outlet valve
CAUTION: Ensure correct mounting position of the upper valve gasket (Fig. 5).
- Insert new inlet and outlet valve into valve head
CAUTION: Observe correct position between valve centre hole and valve head centre pin.
- Place lower valve gasket
- Place valve head with the new inlet and outlet valve. Tighten valve head screws crosswise (tightening torque 35 Nm).
- Connect pipe connections and tighten.

The inlet and outlet valves change is now completed.

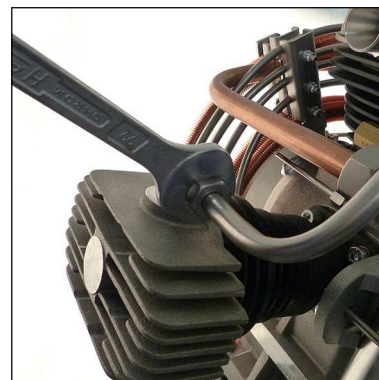

Fig. 1 - Loosen pipe connections



Fig. 2 - Loosen valve head screws

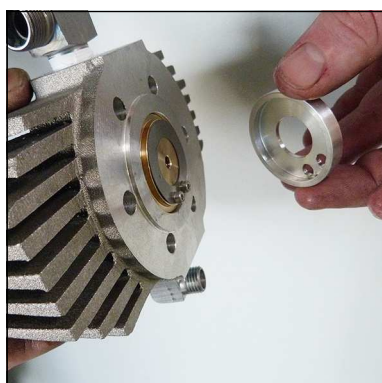

Fig. 3 - Remove lower valve gasket



Fig. 4 - Remove inlet and outlet valve



Fig. 5 - Ensure correct mounting position of the upper valve gasket

MAINTENANCE AND SERVICE

Safety valves

Every pressure stage is equipped with a separate over pressure safety valve. Safety Valves avoid a non permissible high pressure at the specific pressure stages and limit maximum operation pressure of the compressor.

Safety valves are adjusted to:

- 1st Stage: 8 bar
- 2nd Stage: 60 bar
- 3rd Stage: max. final pressure

The adjusted blow-off pressure [bar] of the safety valves is indicated on their housings.

All safety valves are factory sealed with special L&W safety seals to avoid manipulation of the limit value settings.

Safety valves with removed seals have to be immediately checked for the prescribed settings and replaced if necessary.

The safety valve of the final stage is furthermore equipped with a knurled screw to be activated once.

Turning the knurled screw clockwise could vent the valve completely and therefore the final filter housing.

During normal operation conditions, the knurled screw has to be turned anti-clockwise up to the upper stop. An integrated circlip avoids complete unscrewing.

If a safety valve blows off, it indicates problems with either inlet or outlet valve of the following stage.



Note

Replace defective safety valves immediately!



Safety valve 1st stage

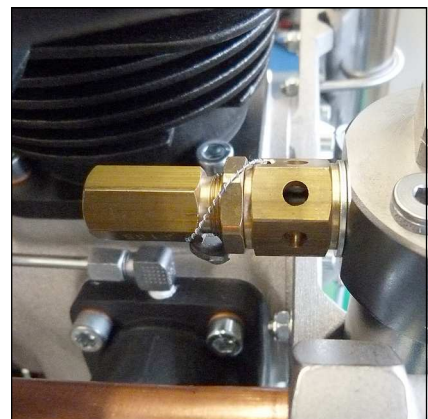

Safety valve 2nd stage



Safety valve 3rd stage

A

Pressure maintaining / non return valve

**Note**

If the adjusted opening pressure of the pressure maintaining valve is higher than the final pressure of the compressor, the final pressure safety valve blows off before pressure maintaining valve opens (final pressure = 0 bar). When valve settings are not clear (e.g. after disassembly / repair), start the adjustment with a low basic setting (turn adjusting screw approx. 3 times in).

A pressure maintaining / non return valve is installed after the mole carbon filter housing. It maintains a pressure of at least 150 bar inside the filter housing - this optimises filter efficiency.

Pressure maintaining valve

The pressure maintaining valve drains a large part of the water content of the compressed air mechanically by ensuring the minimum outlet pressure. This guarantees optimal drying and purification of the breathing air.

After starting the compressor, the pressure inside the final filter housing constantly increases. The pressure maintaining valve prevents the compressed air from blowing off (final pressure gauge = 0 bar).

When the adjusted opening pressure is reached (150 and 180 bar), the purified compressed air flows via pressure maintaining and non return valve to the filling valve.

The value of the opening pressure of the pressure maintaining valve can be read at the final pressure gauge. When opening pressure is reached, the pressure gauge value increases within a few seconds.



Pressure maintaining/non-return valve

MAINTENANCE AND SERVICE

Safety valve test



Note

Do not fill any tank during test phase!

Safety valve test as follows:

- Disconnect compressor from the electrical power supply and protect against unexpected restart.
- Remove the cover of the switch box.
- Switch on the "Test Safety Valve" switch (pressure switch will be deactivated!).
- Mount the cover of the switch box.
- Connect the compressor to the electrical power supply.
- Close filling valves.
- Start the compressor.
- Watch the final pressure gauge. The safety valve should open when reaching working pressure of the compressor. If not, switch off the unit and take out of service until the safety valve has been replaced.
- Switch off the compressor.
- Disconnect the compressor from the electrical power supply and protect against unexpected restart.
- Remove the cover of the switch box.
- Switch off the "Test Safety Valve" switch (pressure switch will be activated!).
- Mount the cover of the switch box.
- Connect the compressor to the electrical power supply.

The safety valve test is now completed.

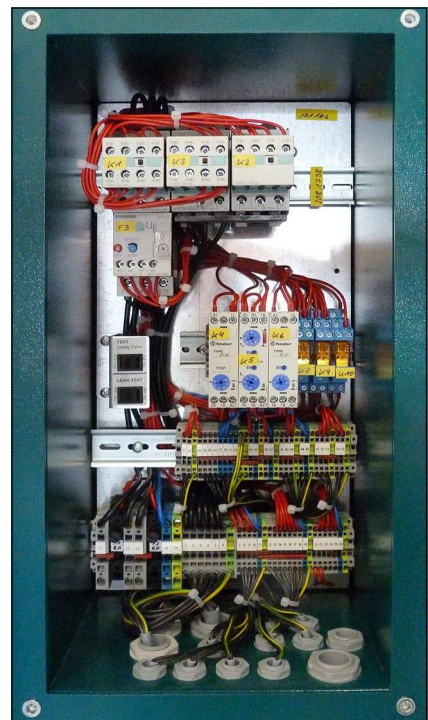

Switch box

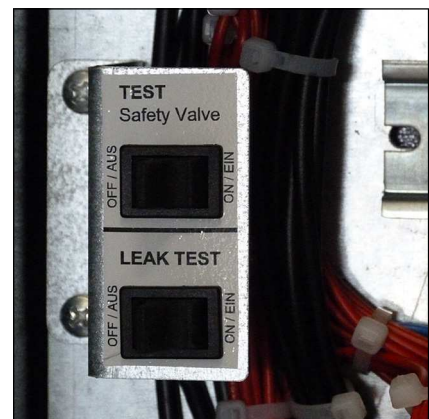

Safety valve test switch (up)

MAINTENANCE AND SERVICE

Leak test



Note

Do not fill any tank during test phase!

Leak test as follows:

- Disconnect the compressor from the electrical power supply and protect against unexpected restart.
- Remove the cover of the switch box.
- Switch on the leak test switch (solenoid valves will be deactivated!).
- Mount the cover of the switch box.
- Connect the compressor to the electrical power supply.
- Close filling valves.
- Start the compressor.
- Switch off the compressor at a pressure of approx. 150 bar.
- Verify the compressor for release noises. (A slight hiss of the air inlet filter nozzle can be ignored). If release noises occur, localise blow off position(s).
- Switch off the compressor.
- Disconnect the compressor from the electrical power supply and protect against unexpected restart.
- Remove the cover of the switch box.
- Switch off the leak test switch (solenoids will be activated!).
- Mount the cover of the switch box.
- Connect the compressor to the electrical power supply.

The leak test is now completed.

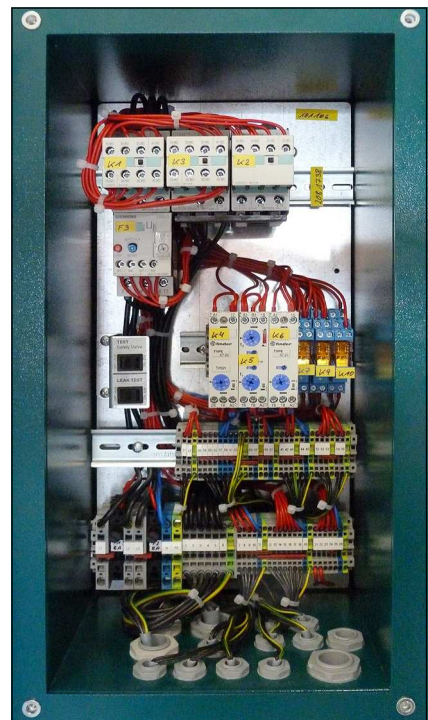

Switch box

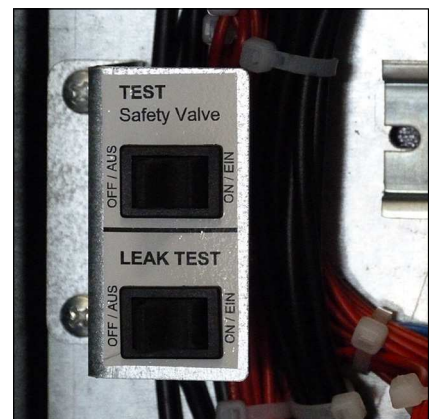

Leak test switch (lower)



MAINTENANCE AND SERVICE

Test of pressure equipment

According to the Pressure Equipment Directive (PED 97/23/EC) and TÜV Darmstadt (German supervising authorities). State: 10th of December, 2005

Subject: pressure equipment with a product permissible operating pressure [bar] x content volume [litres] from 200 up to 1000.

Example: Filter housing 1.7 l

Maximum operating pressure: 350 bar

Content volume: 1.7 litres

$350 \text{ bar} \times 1.7 \text{ litres} = 595$

595 is smaller than 1000 -> result: Test is applicable!!

Example: Filter housing 2.3 l

Maximum operating pressure: 350 bar

Content volume: 2.3 litres

$350 \text{ bar} \times 2.3 \text{ litres} = 805$

805 is smaller than 1000 -> result: Test is applicable!!

Pressure equipment from 200 up to 1000 have to be tested as follows:

1. Examination after 5 years by a qualified person or authorized organisations.

Visual inspection, inside and outside.

2. Examination after 10 years by a qualified person or authorized organisations.

Visual inspection, inside and outside.

In addition, a water pressure test is carried out at 1.5 times of the permissible vessel operating pressure.



A

MAINTENANCE RECORDS



MAINTENANCE RECORDS

Introduction form for the Operator

A

| No. | Surname, Name | Date | Place | Signature | Instructor |
|-----|---------------|------|-------|-----------|------------|
| | | | | | |
| | | | | | |
| | | | | | |
| | | | | | |
| | | | | | |
| | | | | | |
| | | | | | |
| | | | | | |
| | | | | | |
| | | | | | |
| | | | | | |
| | | | | | |
| | | | | | |
| | | | | | |
| | | | | | |
| | | | | | |
| | | | | | |
| | | | | | |
| | | | | | |
| | | | | | |
| | | | | | |

By adding themselves to this list, the person that signs it confirms having been given a yearly introduction/instruction about the function and operation of the compressor unit. Furthermore, they have been informed about the relevant safety rules and regulations (TRG, DGRL, BetrSichV, GSG, GSGV).



MAINTENANCE RECORDS

Top up oil, oil change

| Date | Operating hours | Oil quantity [l] | Name |
|------|-----------------|------------------|------|
| | | | |
| | | | |
| | | | |
| | | | |
| | | | |
| | | | |
| | | | |
| | | | |
| | | | |
| | | | |
| | | | |
| | | | |
| | | | |
| | | | |
| | | | |
| | | | |
| | | | |
| | | | |
| | | | |
| | | | |

A



MAINTENANCE RECORDS

Cartridge change

A

| Date | Operating hours | Difference | Name |
|------|-----------------|------------|------|
| | | | |
| | | | |
| | | | |
| | | | |
| | | | |
| | | | |
| | | | |
| | | | |
| | | | |
| | | | |
| | | | |
| | | | |
| | | | |
| | | | |
| | | | |
| | | | |
| | | | |
| | | | |
| | | | |
| | | | |
| | | | |
| | | | |
| | | | |



MAINTENANCE RECORDS

Maintenance work

A

| Description | Date, signature |
|-------------|-----------------|
| | |
| | |
| | |
| | |
| | |
| | |
| | |
| | |
| | |
| | |
| | |
| | |
| | |
| | |
| | |
| | |
| | |



MAINTENANCE RECORDS

Replaced Parts

| Designation | Part number | Date, signature |
|-------------|-------------|-----------------|
| | | |
| | | |
| | | |
| | | |
| | | |
| | | |
| | | |
| | | |
| | | |
| | | |
| | | |
| | | |
| | | |
| | | |
| | | |
| | | |
| | | |

A

STORAGE

Conservation / storage of the compressor

If the compressor unit is not to be used for an extended period of time, we recommend to carry out the following work before storage time:

- Run the compressor at 200 bar filling pressure for approximately ten minutes (control the flow with the filling valve to maintain constant pressure).
- Replace compressor oil, open filling valve(s) and run compressor for a few minutes.
- Stop compressor and open drain valves (depending on the compressor type, this may happen automatically). Remove top cap of final filter housing: clean throat, grease o-ring. and throat with a food grade grease or silicone grease. Close filter housing.
- Remove intake filter cartridge and undo intake pipes on all valve heads.
- Start compressor unit. Spray a few drops of compressor oil into intake connectors.
- Stop compressor unit and insert intake filter cartridge. Bring intake pipes back in position and fix connections and nuts. Close filling- and drain valves.
- Store the compressor in a cool dry place free from dust and contamination. A dust cover is recommended as long as condensation can be avoided.
- If compressor unit should be stored for a period of more than one year, an oil change is strongly recommended before it's been re-used.
- Fuel driven units only: fill up fuel tank to top level to avoid corrosion.

De-conservation, commissioning

After the compressor has been stored, the following steps are to be taken:

- If compressor hasn't been used for longer than 12 months, we strongly recommend an oil change before any use.
- Replace intake filter cartridge and check oil level.
- Clean compressor unit, check for foreign objects. Check condition and tension of V-belts, replace if necessary. Check condition of filling hoses, replace if necessary.
- Secure hoses against whipping and open filling valves and run compressor for approximately 10 minutes.
- Check condition of final filter cartridge, replace if necessary.
- Close filling valves and run compressor up to final pressure.
- Check safety valve relief pressure of final stage and/or pressure switch setting.
- Check all connections and pipe work for leaks.

Once all above steps are completed, compressor unit is now ready for use.

STORAGE

Transportation instructions

- Parts which need to be dismantled for transport purposes must be carefully replaced and secured before taking into operation.
- The transport may only be carried out by trained personnel.
- For transportation, only use lifting devices and equipment with sufficient lifting power.
- Do not stand or work under suspended loads.
- Also separate from minor relocation machinery / system of any external energy supply. Before recommissioning, reconnect the machine to the mains according to regulations.
- When recommissioning, proceed according to the operating instructions..

Disposal

The product must be disposed in accordance with national waste disposal regulations and by an appropriate waste disposal company.

Electric and electronic components

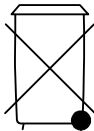

EU-wide regulations for the disposal of electric and electronic appliances which have been defined in the EU Directive 2002/96/EC and in national laws are effective from August 2005 and apply to this device.

Common household appliances can be disposed by using special collecting and recycling facilities. However, as this device has not been registered for household usage, it must not be disposed of through these means.

The device can be returned to L&W. Please do not hesitate to contact us if you have any further questions on this issue.

Operating Instructions

ECC - Electronic compressor control





TABLE OF CONTENTS

General Information

| | |
|--------------------------------------|---|
| General Information | 3 |
| Description of Warning Symbols | 3 |

Description

| | |
|--------------------------------|---|
| Specifications / Options | 4 |
| Switchboard | 5 |

Operation and Function

| | |
|--|----|
| Main Menu | 6 |
| Selection Menu (M100) | 7 |
| Display Menu (M200) | 8 |
| Inter-Stage Pressure Display..... | 8 |
| Display II (M270) | 9 |
| Settings Menu (M300)..... | 10 |
| Set Stop Pressure - automatic mode (M320)..... | 11 |
| Set Restart Pressure - automatic mode (M330)..... | 11 |
| Set Stop Pressure - semi-automatic mode (M340) | 11 |
| Test Menu (M400) | 12 |
| Test Solenoids (M420) | 12 |
| Test safety valve (M430) | 13 |
| Test stop without venting (M440) | 13 |
| Statistics Menu (M500)..... | 14 |
| Maintenance Menu (M600) | 15 |
| Confirm Maintenance (M680)..... | 16 |
| Operation Mode (M700)..... | 17 |
| Language Menu (M750) | 17 |
| Adjusting Display Backlight..... | 18 |
| Software Update | 18 |
| Spare part lists..... | 19 |
| Manufacturer in terms of 97/23/EC..... | 20 |

B

GENERAL INFORMATION

General Information

We strongly recommend reading this manual thoroughly prior to operation and follow all the safety precautions precisely. Damage resulting from any deviation from these instructions is excluded from warranty and liability for this product. Carry out other commissioning steps only if you have fully understood the following contents.

Before commissioning and using the unit, carry out all the essential preliminary work and measures concerning legal regulations and safety. These are described on the following pages of this operation manual.

B

Description of marks and warning signs

The following warning signs are used in this document to identify the corresponding warning notes which require particular attention by the user. The warning signs are defined as follows:



Caution

Indicates an imminently hazardous situation which, if not avoided, could result in serious injury, physical injury or death.



Warning

Indicates a potentially hazardous situation which, if not avoided, could result in physical injury or damage to the product or environment.



Note

Indicates additional information on how to use the unit.



DESCRIPTION

Specifications and Options

All L&W compressors can be optionally equipped with the all-electrical computer supported control system "ECC". It is easy to operate and allows multiple and individual settings.

Specifications

- LCD-Display with key pad
- Automatic & semi-automatic operation mode
- Automatic dump system
- Integrated counter for operation hours
- Integrated counter for load cycles
- Maintenance intervals automatically displayed
- Required service part numbers automatically displayed
- Fully adjustable pressure ranges for start and stop
- Warning messages ("Housing Open" / "Emergency Switch")
- Check of end-pressure safety valve possible
- Auto switch-off when system is not running
- Extendable by additional modules (e.g. external filling panel)
- Easy to operate menu
- Door position switch (housing open message)
- Load-free or depressurised start cycles

Options

- Oil pressure control
- Oil temperature control
- Cylinder head temperature control
- Inter stage pressure monitoring
- PIN controlled access
- Master / slave option (if more than one ECC equipped compressors are combined)

DESCRIPTION

Switchboard



| No. | Description |
|-----|------------------------------|
| 1 | LCD Display |
| 2 | Key Pad |
| 3 | LED Display (Compressor OFF) |
| 4 | LED Display (Power) |
| 5 | LED Display (Compressor ON) |



OPERATION AND FUNCTION

Main Menu

Immediately after the compressor has been connected to power, the ECC-display shows the following Main Menu::

| | |
|-------------|--------------|
| Charging | 0 min |
| Total | 0,0 h |
| Start : 1 | Stop : 0 |
| Help: * | OFF |
| Final Press | 0 bar |

Present filling time in minutes

Total operation hours

Key 1 to start compressor / Key 0 to stop compressor

* Key leads to submenus Current operation state = Off

Present filling pressure

B

The following keys can now be used:

| Key | Function / Description |
|-----|-------------------------------|
| 1 | Start - Starts the compressor |
| 0 | Stop - Stops the compressor |
| * | Leads to the submenus |

After typing the * key the following Selection Menu appears.



OPERATION AND FUNCTION

Selection Menu (M100)

After typing the * key in the Main Menu the following Selection Menu appears.

| Selection: | | |
|------------|----------------|---|
| 2 | Display | Key 2 leads to submenu "Display" |
| 3 | Settings | Key 3 leads to submenu "Settings" |
| 4 | Test | Key 4 leads to submenu "Test" |
| 5 | Statistics | Key 5 leads to submenu "Statistics" |
| 6 | Maintenance | Key 6 leads to submenu "Maintenance" |
| 7 | Operation Mode | Key 7 leads to submenu "Operation mode" |
| (M100) | Return : # | Key # leads back to "Main Menu" |

(M100) tells that you are currently on menu page 100.



Note

At any time, the unit can be started with key 1 or shut down with key 0.
Caution: Risk of accident during maintenance work!

OPERATION AND FUNCTION

Display Menu (M200)

Pushing key 2 in the Selection Menu leads to Submenu "Display".

| Display I: | |
|------------|-----------------|
| 2 | Press. Stage 1 |
| 3 | Press. Stage 2 |
| 4 | Press. Stage 3 |
| 5 | Cyl. Head Temp. |
| 6 | Oil Temp. |
| 7 | Display II |
| (M200) | Return : # |

Key 2 shows current pressure of the 1st stage*

Key 3 shows current pressure of the 2nd stage

Key 4 shows current pressure of the 3rd stage

Key 5 shows temperature of the final stage cylinder head

Key 6 shows the oil temperature

Key 7 shows Display II

Key # leads back to "Main Menu"

(M200) tells that you are currently on menu page 200.

By pushing key 2 (inter-stage pressure 1) the following Display appears.

Inter-Stage Pressure Display

Pushing key 2 in the Display Menu leads to the Inter-Stage Pressure 1 Display Menu.

| | |
|-----------------------|---------|
| Charging | 0 min |
| Total | 0,0 h |
| Start: 1 | Stop: 0 |
| Help:* | OFF |
| Press. | 0 bar |
| 1 st Stage | 0,0 bar |

Use keys 3 to 6 in the Menu "Display I" to change between the displayed values.



Note

Pushing key 8 in the display menu "Display II" leads to the option "Pressure200/300" for compressors with 2 filling pressures. Displayed in field 3 of the display menu "Display I".



OPERATION AND FUNCTION

Display II (M270)

Pushing key 7 in the Selection Menu leads to Menu "Display II".

Display II:

| Press. | Temp. |
|--------|------------|
| 4: 0 | C: 0 |
| 5: 0 | D: 0 |
| 6: 0 | E: 0 |
| 7: 0 | F: 0 |
| bar | °C |
| (M270) | Return : # |

This display shows further customer specific pressure and temperature values.

Key # leads back to "Main Menu"

B

OPERATION AND FUNCTION

Settings Menu (M300)

Pushing key 3 in the Selection Menu leads to the Settings Menu.

| | |
|-----------------------|----------------|
| Settings: | |
| Automatic | |
| 2 | Stop pressure |
| 3 | Restart Press. |
| Semi-Automatic | |
| 4 | Stop Pressure |
| 9 | Close |
| (M300) | Return : # |

Key 2 leads to submenu „Set Stop Pressure“

Key 3 leads to submenu „Set Restart Pressure“

Key 4 leads to submenu „Set Stop Pressure“

Key 9 leads back to submenu "Selection"

Key # leads back to "Main Menu"

Use menu M700 to change between "Automatic" and "Semi-Automatic" mode.

Restart pressure can only be set in "Automatic Mode".

Prior to setting the pressure, start the safety valve test.



Attention during maintenance

During automatic mode, the compressor can automatically start by itself at any time, depending on the selected restart pressure (see "Set Restart Pressure" M330).



OPERATION AND FUNCTION

Set Stop Pressure - automatic mode (M320)

Only valid in automatic mode, see menu M700.

Set
Stop Pressure:
Actual: 330 bar
7 New Value:
>> XXX bar
4 (050,, 333)
8 Confirm
(M320) Return : #

Current restart pressure
Key 7 if restart pressure should be changed
XXX indicates modified stop pressure
Chooseable pressure range for restart pressure
Key 8 confirms new restart pressure
Key # leads back to "Main Menu"

B

Set Restart Pressure - automatic mode (M330)

Only valid in automatic mode, see menu M700.

Set
Restart Pressure:
Actual: 180 bar
7 New Value:
>> XXX bar
4 (030,, 310)
8 Confirm
(M330) Return : #

Current restart pressure
Key 7 if restart pressure should be changed
XXX indicates modified restart pressure
Chooseable pressure range for restart pressure
Key 8 confirms new restart pressure
Key # leads back to "Main Menu"

Set Stop Pressure - semi-automatic mode (M340)

Only valid in semi-automatic mode, see menu M700.

Set
Stop Pressure:
Actual: 180 bar
7 New Value:
>> XXX bar
4 (030,, 310)
8 Confirm
(M340) Return : #

Current stop pressure
Key 7 if stop pressure should be changed
XXX indicates modified stop pressure
Chooseable pressure range for stop pressure
Key 8 confirms new restart pressure
Key # leads back to "Main Menu"

OPERATION AND FUNCTION

Test Menu (M400)

Pushing key 4 in the Selection Menu leads to the Test Menu.

| Test: | |
|--------|--------------|
| 2 | Solenoids |
| 3 | Safety Valve |
| 4 | Test-Stop |
| 9 | Close |
| (M400) | Return : # |

Key 2 leads to submenu "Test Solenoids"

Key 3 leads to submenu "Test Safety Valve"

Key 4 leads to submenu "Test Stop without Venting"

Key 9 leads back to submenu "Selection"

Key # leads back to "Main Menu"

B

Test Solenoids (M420)

Pushing key 2 in the Selection Menu leads to Submenu "Test Solenoids".

| Test Solenoids | |
|----------------|------------|
| 3 | open |
| 7 | close |
| 9 | Close |
| (M420) | Return : # |

Key 3 opens solenoids

Key 7 closes solenoids

Key 9 leads back to submenu „Test“

Key # leads back to "Main Menu"



Note

This menu can not be left unless solenoids have been closed by key 7.

OPERATION AND FUNCTION

Test safety valve (M430)

Pushing key 3 in the Test Menu leads to Submenu "Test Safety Valve".



Note

Prior to starting the Test, close all filling connections (also connected filling panels if necessary). During this test, the compressor passes the selected stop pressure (see Menu M320) to test the correct function of the final pressure safety valve. This would limit the maximum operating over pressure of the unit in case of malfunction.

B

Test

Safety Valve

Close Filling Valves!

| | |
|-------------------|--------|
| 5 Start | 0 Stop |
| 9 Close | |
| (M430) Return : # | |

Key 5 to start test Key 0 to stop test

Key 9 leads back to submenu „Test“

Key # leads back to "Main Menu"

Test stop without venting (M440)

Pushing key 4 in the Test Menu leads to Menu "Test Stop without Venting".



Note

This test is only operable when the compressor has been started with key 1. This test mainly checks the leak tightness of pressure vessels, pressurised pipes, safety valves and the compressor block.

Test

stop without venting:

| | |
|-------------------|-----|
| 5 Stop | |
| 6 Vent | |
| Pressure | 0 |
| | bar |
| 9 Close | |
| (M440) Return : # | |

Key 5 stops compressor during test run

Key 6 vents compressor after leak search has been finished

Shows current filling pressure

Key 9 leads back to submenu „Test“

Key # leads back to "Main Menu"



OPERATION AND FUNCTION

Statistics Menu (M500)

Pushing key 5 in the Selection Menu leads to Submenu "Statistics".

| Statistics | |
|-------------------|---------|
| Operation Hours: | 0,0 h |
| Start cycles: | 00 |
| Max Press | 000 bar |
| 9 Close | |
| (M500) Return : # | |

Total operation hours of compressor unit

Total number of compressor starts

Maximum working pressure of unit (set by safety valve test)

Key 9 leads back to submenu „Selection“

Key # leads back to "Main Menu"

Push key 5 to get information on which ECC software version is currently installed on your system (M505), i.e.: By pushing key 2, the total load cycles of the filter housing are being indicated.

B

OPERATION AND FUNCTION

Maintenance Menu (M600)

Pushing key 6 in the Selection Menu leads to the "Maintenance Menu".

| Hours remaining | | |
|-------------------|--------|--|
| Oil change | 14 h | Shows remaining hours of listed components (i.e. next oil change in 14 hours,...) |
| Sinter filt | 989 h | |
| Silencer | 4989 h | |
| Valves | 5989 h | |
| Oil filter | 1000 h | |
| 8 Change done | | Key 8 leads to submenu "Receipt Maintenance" |
| 9 Close | | Key 9 leads back to submenu „Selection“ |
| (M600) Return : # | | Key # leads back to "Main Menu" |

Remaining hours depend on the type. At the end of any remaining hours, the display indicates a warning message. Furthermore, the display informs about any possibly necessary spare parts with the corresponding L&W service part number.



Attention during maintenance

During automatic mode, the compressor can automatically start by itself at any time, depending on the selected restart pressure (see "Set Restart Pressure" M330).



OPERATION AND FUNCTION

Confirm Maintenance (M680)

| Confirm Maintenance | |
|---------------------|----------------|
| 2 | Oil change |
| 3 | Sinter filters |
| 4 | Silencer |
| 5 | Valves |
| 6 | Oil filter |
| (M680) | Return : # |

Key 2 receipts oil change
Key 3 receipts change of sinter filters
Key 4 receipts change of silencer
Key 5 receipts change of valves
Key 6 receipts oil filter
Key # leads back to "Main Menu"

B

Display confirms any reset of "Hours remaining" with the following message:

| Confirm Maintenance | |
|---------------------------|------------|
| Operation Hours Meter Set | |
| 9 | Close |
| (M680) | Return : # |

Key 9 leads back to submenu "Hours remaining"
Key # leads back to "Main Menu"

OPERATION AND FUNCTION

Operation Mode (M700)

Pushing key 7 in the Selection Menu leads to the menu "Operation Mode".

Activated modes are always displayed in bolt letters (above example: **Semi-Automatic**).

Further settings can be made in the Settings Menu (M300).

B

| Betriebsart: | |
|--------------|-----------------------|
| 2 | Automatic |
| 3 | Semi-Automatic |
| 4 | bar /mpa |
| 5 | Sprache |
| 9 | Close |
| (M700) | Return : # |

Key 2 activates automatic mode

Key 3 activates semi-automatic mode

Key 4 selects between bar and MPa (optional)

Key 5 leads to the "Language Menu"

Key 9 leads back to submenu „Selection“

Key # leads back to "Main Menu"

Language Menu (M750)

| Language Menu | |
|---------------|-------------|
| 2 | German |
| 3 | English |
| 4 | French |
| 5 | Spanish |
| 6 | Dutch |
| 7 | Language II |
| (M750) | Return : # |

Key 7 optional language (e.g. Chinese)

Key # leads back to "Main Menu"

OPERATION AND FUNCTION

Adjusting Display Backlight

The brightness of the display can be adjusted with an adjusting screw on the back of the control.

Software Update

Software updates can only be carried out by L&W. To carry out an update, the device has to be send to the L&W service.



Adjust brightness

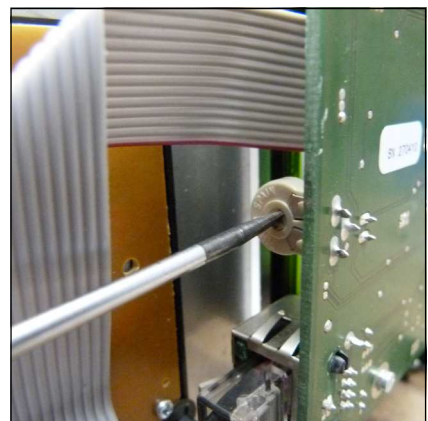

Adjust brightness

SPARE PART LISTS

| Best.-Nr. / Order No. | Benennung | Description |
|-----------------------|--|---|
| 002141 | 1. Stufe Druckaufnehmer 0-10 bar | 1st stage pressure sensor 0-10 bar |
| 002142 | 2. Stufe Druckaufnehmer 0-60 bar | 2nd stage pressure sensor 0-60 bar |
| 002143 | Endstufe Druckaufnehmer 0-400 bar | Final stage pressure sensor 0-400 bar |
| 006890 | Druckaufnehmer 420 bar Version 0-600 bar | Pressure sensor 420 bar version 0-600 bar |
| 004840 | Öldruckaufnehmer 0-6 bar | Oil pressure sensor 0-6 bar |
| 006912 | Öltemperatursensor | Oil temperature sensor |
| 003501 | Zylinderkopf - Temperatursensor | Cylinderhead temperature sensor |

B



002141 / 002142 / 002143 / 004840
Druckaufnehmer / Pressure sensor



006890 - Druckaufnehmer 420 bar /
Pressure sensor 420 bar



006912 - Öltemperatursensor
Oil temperature sensor



003501 - Zylinderkopf - Temperatursensor
Cylinderhead temperature sensor



LENHARDT & WAGNER GMBH

B

Manufacturer in terms of 97/23/EC

The full name and address of the manufacturer is:

Lenhardt & Wagner GmbH

An der Tuchbleiche 39
68623 Hüttenfeld / Germany

Phone: +49 (0) 62 56 - 85 88 0 - 0

Fax: +49 (0) 62 56 - 85 88 0 - 14

E-Mail: service@lw-compressors.com

Internet: www.lw-compressors.com





**ERSATZTEILLISTEN / SPARE PARTS LISTS
DETAILANSICHTEN / DETAILED VIEWS**

C



Inhaltsverzeichnis - Table of Contents

| | |
|--|----|
| Kompressorgehäuse - Compressor Housing..... | 3 |
| Schalttafel - Control Board..... | 6 |
| Fülldruckmanometer & Schlauch - Filling pressure Gauge & Hose..... | 8 |
| Kompressorblock - Compressor Block..... | 10 |
| Öl-Wasserabscheider 1.+2. Stufe - Oil-Water Separator 1st+2nd Stage..... | 14 |
| Magnetventil 2.+3. Stufe - Solenoid Valve 2nd+3rd Stage..... | 16 |
| Filtergehäuse 1,7l - Filter Housing 1.7ltr..... | 18 |
| Öl+Wasserabscheider Endstufe - Oil+Water Separator Final Stage..... | 20 |
| Ansaugfilter - Air Intake Filter..... | 22 |
| Pneum. Kondensatventil - Pneuma. Condensate Valve..... | 24 |
| Sicherheitsventil - Safety Valve..... | 26 |
| Motor..... | 28 |
| Druckschalter - Pressure Switch..... | 30 |
| Kolben 1. Stufe - Piston 1st Stage..... | 32 |
| Kolben 2. Stufe - Piston 2nd Stage..... | 34 |
| Kolben 3. Stufe - Piston 3rd Stage..... | 36 |
| Kurbelwelle - Crankshaft..... | 38 |
| Kühlrohre - Cooling Pipes..... | 40 |
| Kühlrohr 3. Stufe - Cooler 3rd Stage..... | 42 |
| Zusatzkühler - Additional Cooler..... | 44 |
| Lüfterrad - Fan Wheel..... | 46 |
| Motor..... | 48 |
| Saug+Druckventil 1. Stufe - In+Outlet Valve 1st stage..... | 50 |
| Saug+Druckventile 2.+3. Stufe - In+Outlet Valves 2nd+3rd Stage..... | 51 |
| Ölablassschlauch - Oil Drainage Tube..... | 52 |



Inhaltsverzeichnis - Table of Contents

| | |
|---|----|
| Ölfilter - Oil Filter..... | 54 |
| Ölpumpe - Oil Pump..... | 56 |
| Füllventile mit Schläuchen - Filling valves with hoses..... | 58 |
| Füllanschlüsse - Filling Connectors..... | 60 |



ERSATZTEILLISTE / SPARE PART LIST

Baugruppe: Kompressorgehäuse / Assembly: Compressor Frame

| Best.-Nr. / Order No. | Benennung | Description |
|-----------------------|--|--|
| 001041 | Zylinderschraube | Allen Screw |
| 001158 | Mutter | Nut M8 |
| 001163 | Mutter | Nut M10 |
| 001181 | U-Scheibe A8 | Washer A8 |
| 001188 | U-Scheibe A10 | Washer A10 |
| 001675 | Gummilager | Rubber Mounts |
| 001676 | Standfuss, Gummi | Rubber Foot |
| 001677 | Griffschale PVC-Schwarz | Plastic Snatch, PVC, black |
| 001678 | Vorreiber kompl. | Lock assembly, chrome plated |
| 001679 | Schlüssel für Vorreiber ES 001678 | Key for Lock assembly 001678 |
| 001682 | Abdeckung Elektrokasten | Switch Box Cover |
| 002537 | Wartungsdeckel seitlich | Service cover ES Housing |
| 002538 | Dämmmatte, Wartungsdeckel | Noise absorbant mat |
| 003524 | Dämmmatte | Noise-absorbant mat |
| 003525 | Dämmmatte | Noise-absorbant mat |
| 003526 | Dämmmatte | Noise-absorbant mat |
| 003527 | Dämmmatte LW 230 / 280 ES | Noise-absorbant mat |
| 003884 | Dämmmatte | Noise absorbent mat |
| 003885 | Dämmmatte | Noise absorbent mat |
| 003886 | Dämmmatte | Noise absorbent mat |
| 003887 | Dämmmatte | Noise absorbent mat |
| 003977 | Dämmmatte, Oberer Zwischenboden | Noise absorbent mat |
| 004158 | Dämmmatte Zwischenboden unten | Noise absorbent mat |
| 004769 | Oberer Zwischenboden | Upper intermediate mat |
| 005094 | Dämmmatte | Noise-absorbent mat |
| 005096 | Armaturenblech Standard LW 280 ES, 1 Manometer | Dashboard standard LW 280 ES, 1 pressure gauge |
| 006164 | Befestigungsklammer Griffschale | Clamp for Moulded Recess |
| 006384 | Tür vorne | Front Door |
| 006781 | Seitenteil links, inkl. E-Schaltkasten | Side Panel left hand side |



ERSATZTEILLISTE / SPARE PART LIST

Baugruppe: Kompressorgehäuse / Assembly: Compressor Frame

| Best.-Nr. / Order No. | Benennung | Description |
|-----------------------|---|---|
| 006782 | Seitenteil rechts | Side Panel right hand side |
| 006783 | Tür hinten | Rear Door - Silent cabinet |
| 007165 | Armaturenblech (ECC) | Dashboard |
| 008594 | Unterer Zwischenboden | Lower intermediate mat |
| 009117 | Grundrahmen LW 280 ES | Main frame LW 280 ES |
| 009118 | Grundplatte LW 280 ES | Baseplate LW 280 ES |
| 009119 | Frontblech LW 280 ES | Front plate LW 280 ES |
| 009120 | Deckel LW 280 ES | Lid LW 280 ES |
| 009121 | Quertraverse, hinten LW 280 ES | Crossbeam, rear LW 280 ES |
| 009122 | Armaturenblech LW 280 ES, 2 Manometer | Dashboard LW 280 ES, 2 pressure gauges |
| 009123 | Armaturenblech LW 280 ES, 3 Manometer | Dashboard LW 280 ES, 3 pressure gauges |
| 009124 | Armaturenblech LW 280 ES, 4 Manometer | Dashboard LW 280 ES, 4 pressure gauges |
| 009125 | Armaturenblech LW 280 ES, 5 Manometer | Dashboard LW 280 ES, 5 pressure gauges |
| 009126 | Armaturenblech LW 280 ES, 6 Manometer | Dashboard LW 280 ES, 6 pressure gauges |
| 009127 | Einlegewinkel, Frontblech LW 280 ES | Angle bracket, front plate LW 280 ES |
| 009128 | Einlegewinkel, hintere Quertraverse LW 280 ES | Angle bracket, rear crossbeam LW 280 ES |

C

DETAILANSICHT / DETAILED VIEW

Baugruppe: Kompressorgehäuse / Assembly: Compressor Frame

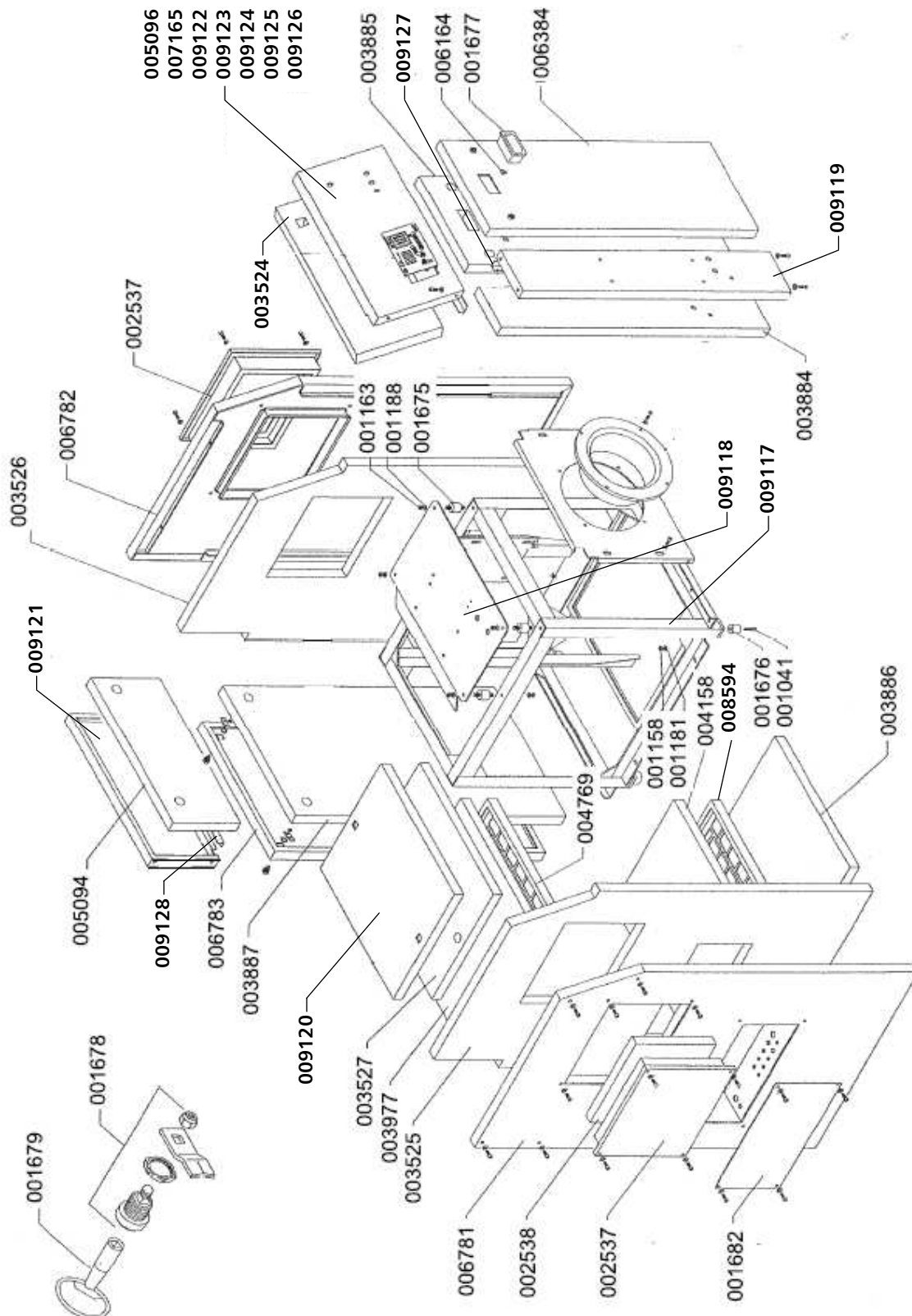



ERSATZTEILLISTE / SPARE PART LIST

Baugruppe: Schalttafel / Control Board

| Best.-Nr. / Order No. | Benennung | Description |
|-----------------------|--|--|
| 002089 | Betriebsstunderzähler 230V | Hour Counter 230V |
| 002502 | Taster blau (komplett inkl. Halterung und Schließer) | Blue button (complete with braket and closing contact) |
| 002504 | Taster grün (komplett inkl. Halterung und Schließer) | Green button (complete with braket and closing contact) |
| 003121 | Not-Halt Schalter | Emergency switch |
| 008153 | Taster rot (komplett inkl. Halterung, Schließer und LED) | Red button (complete with braket, closing contact and LED) |

C

DETAILANSICHT / DETAILED VIEW

Baugruppe: Schalttafel / Control Board

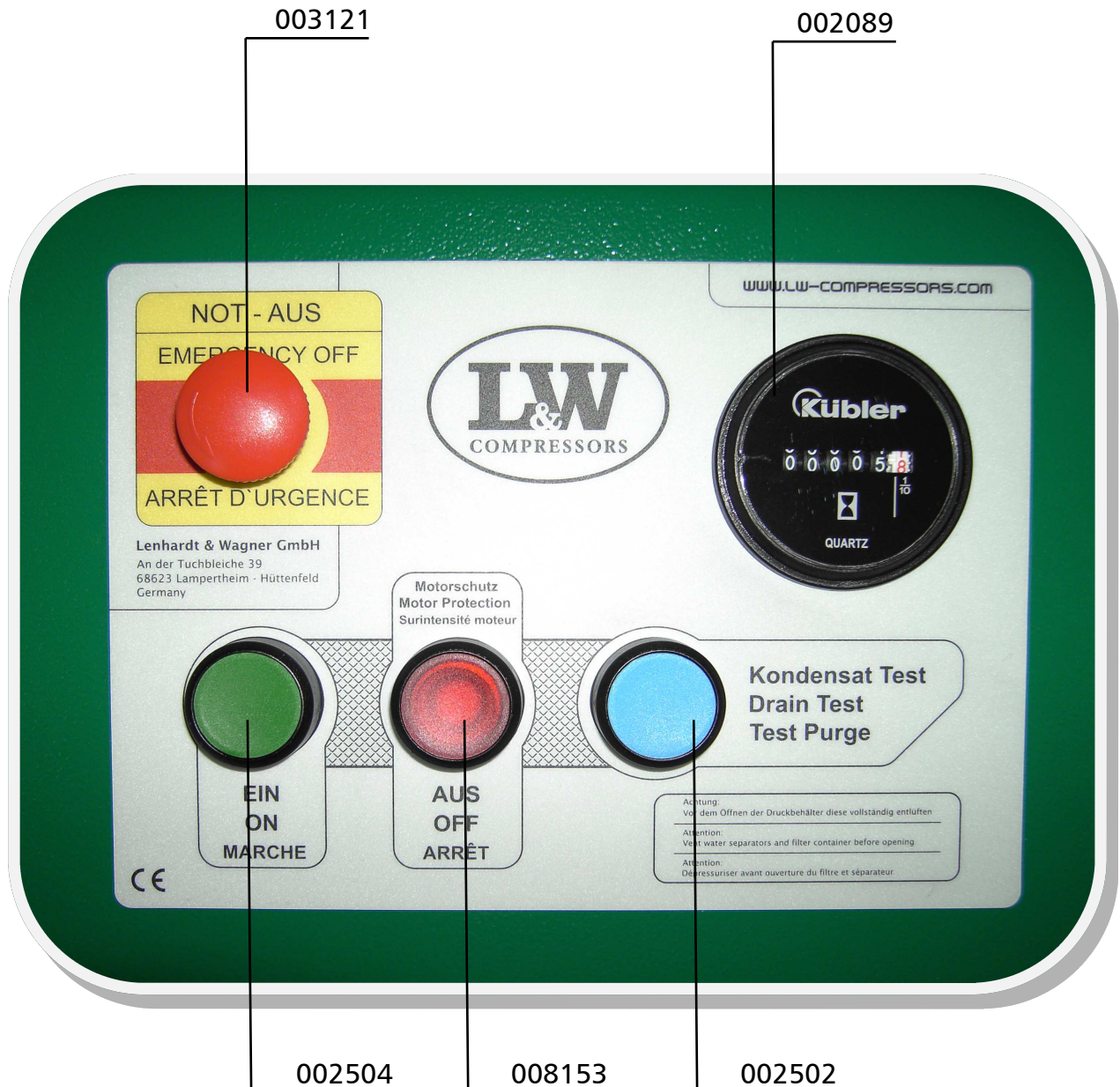

C



ERSATZTEILLISTE / SPARE PART LIST

Baugruppe: Fülldruckmanometer & Schlauch / Filling Pressure Gauge & Hose

| Best.-Nr. / Order No. | Benennung | Description |
|-----------------------|-------------------------|--------------------------|
| 000663 | Manometer 0-400 bar | Pressure Gauge 0-400 bar |
| 001445 | Hochdruckschlauch 600mm | High Pressure Hose 600mm |
| 002506 | Manometer 0-250 bar | Pressure Gauge 0-250 bar |

C

DETAILANSICHT / DETAILED VIEW

Baugruppe: Fülldruckmanometer & Schlauch / Filling Pressure Gauge & Hose

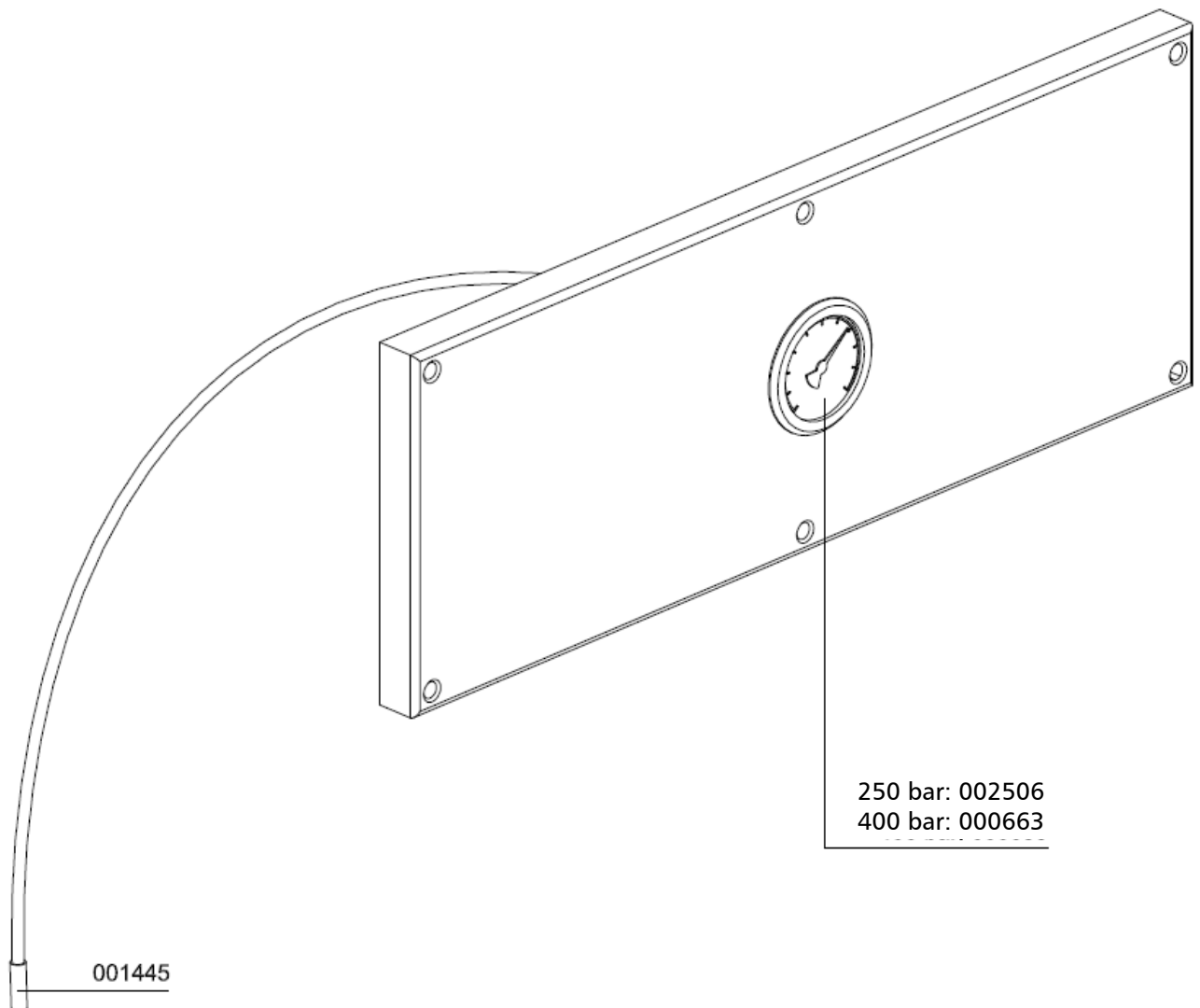

C



ERSATZTEILLISTE / SPARE PART LIST

Baugruppe: Kompressorblock / Assembly: Compressor Block

| Best.-Nr. / Order No. | Benennung | Description |
|-----------------------|--|--------------------------------|
| 000205 | Kurbelgehäuseentlüftungsventil | Crankcase Breather Valve |
| 000257 | Obere Ventildichtung, 1. Stufe | Upper Valve Gasket, Paper, 1st |
| 000258 | Untere Ventildichtung | Lower Valve Gasket, Copper |
| 000432 | Ölmesstab | Oil Dip Stick LW 280 |
| 000542 | Saug- & Druckventil, 2. Stufe komplett | In- & Outlet Valve, 2nd Stage |
| 000543 | Saug-Druckventil kompl.mit Aludichtungen | In- & Outlet Valve, 3rd Stage |
| 000761 | Verschraubung | Elbow Connection |
| 000765 | Schneidring | Olive Seal |
| 000766 | Mutter | Nut |
| 000783 | Verschraubung | Straight Connection |
| 000811 | Verschraubung | Elbow Connection WE3/8"/12L |
| 000863 | Winkelverschraubung 90° | Elbow Connection |
| 000967 | Zylinderschraube | Allen Bolt |
| 001041 | Zylinderschraube | Allen Screw |
| 001069 | Zylinderschraube | Allen Bolt |
| 001088 | Zylinderschraube | Hexagon Bolt |
| 001164 | Stopfmutter | Lock Nut M10 |
| 001181 | U-Scheibe A8 | Washer A8 |
| 001186 | U-Scheibe A10 | Washer A10 |
| 001189 | Schnorr-Scheibe S10 | Clamp Washer S10 |
| 001275 | O-Ring | O-Ring guide cylinder 280 |
| 001284 | O-Ring | O-Ring 60x4 |
| 001310 | O-Ring, | O-Ring 105x4 |
| 001314 | O-Ring | O-Ring |
| 001315 | O-Ring | O-Ring |
| 001323 | CU-Ring | Copper Seal Ring |
| 001384 | Kompressorblock LW280 mit Testlauf | Compressor Block LW280 |
| 001623 | Zylinder 3. Stufe | Cylinder 3rd Stage |
| 001650 | Gehäusedeckel | Crankcase Cover |



ERSATZTEILLISTE / SPARE PART LIST

Baugruppe: Kompressorblock / Assembly: Compressor Block

| Best.-Nr. / Order No. | Benennung | Description |
|-----------------------|-------------------------------------|--------------------------------|
| 001660 | Winkelverschraubung mit Düse | Elbow Connection c/w Jet |
| 002093 | Saug-und Druckventil, 1. Stufe | In & Outlet Valve 1st Stage |
| 002096 | Zylinder 1. Stufe | Cylinder, 1st Stage |
| 002107 | Zylinder 2. Stufe | Cylinder, 2nd Stage |
| 002108 | Führungszylinder 2. + 3. Stufe | Guide cylinder 2nd+3rd Stage |
| 002121 | Ventilkopf, 2. Stufe | Valve head 2nd Stage |
| 002124 | Ventilkopf 3. Stufe | Valve head 3rd Stage |
| 002154 | T-Stück mit Düse (lang) | T-piece with injector (long) |
| 002155 | T-Stück mit Düse (kurz) | T-piece with injector (short) |
| 002157 | Ölansaugrohr | Oil intake pipe |
| 002158 | Ölrohr (Lagerflansch - 3. Stufe) | Oil Pipe (Flange - 3rd Stage) |
| 002159 | Ölrohr (Ölpumpe - Ölfilter) | Oil pipe (oil pump-oil filter) |
| 002160 | Ölrohr (Oelfilter - 2.Stufe) | Oil pipe (oil filt.-2nd Stage) |
| 003583 | Öldruckleitung 2. Stufe | Oil pipe 2nd stage |
| 004982 | Dichtring für Peilstab | Gasket seal for oil dipstick |
| 005239 | Verbindungsrohr | Connection pipe |
| 005837 | Sechskantschraube m. Schaft | Hexagon Bolt |
| 005859 | Gerade Einschraubverschraubung 6 mm | Straight Hose Connection 6 mm |
| 006518 | Ventilkopf für Ventil, 1. Stufe | Valve Head for Valve 1st Stage |
| 007434 | Entlüftungsschlauch Kurbelgehäuse | Crankcase Breather Hose |

C

DETAILANSICHT / DETAILED VIEW

Baugruppe: Kompressorblock / Assembly: Compressor Block

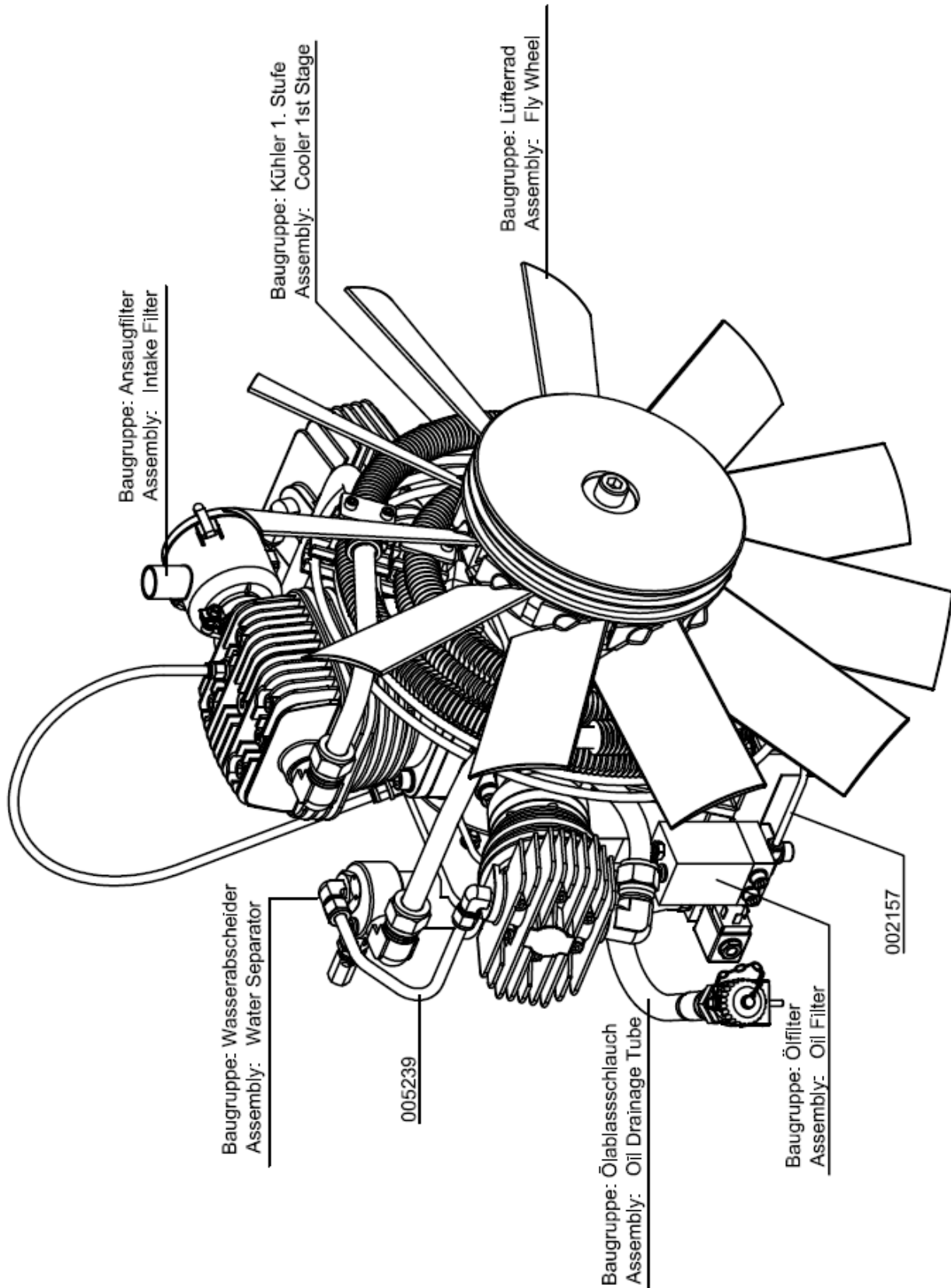

C

Baugruppe: Kompressorblock / Assembly: Compressor Block

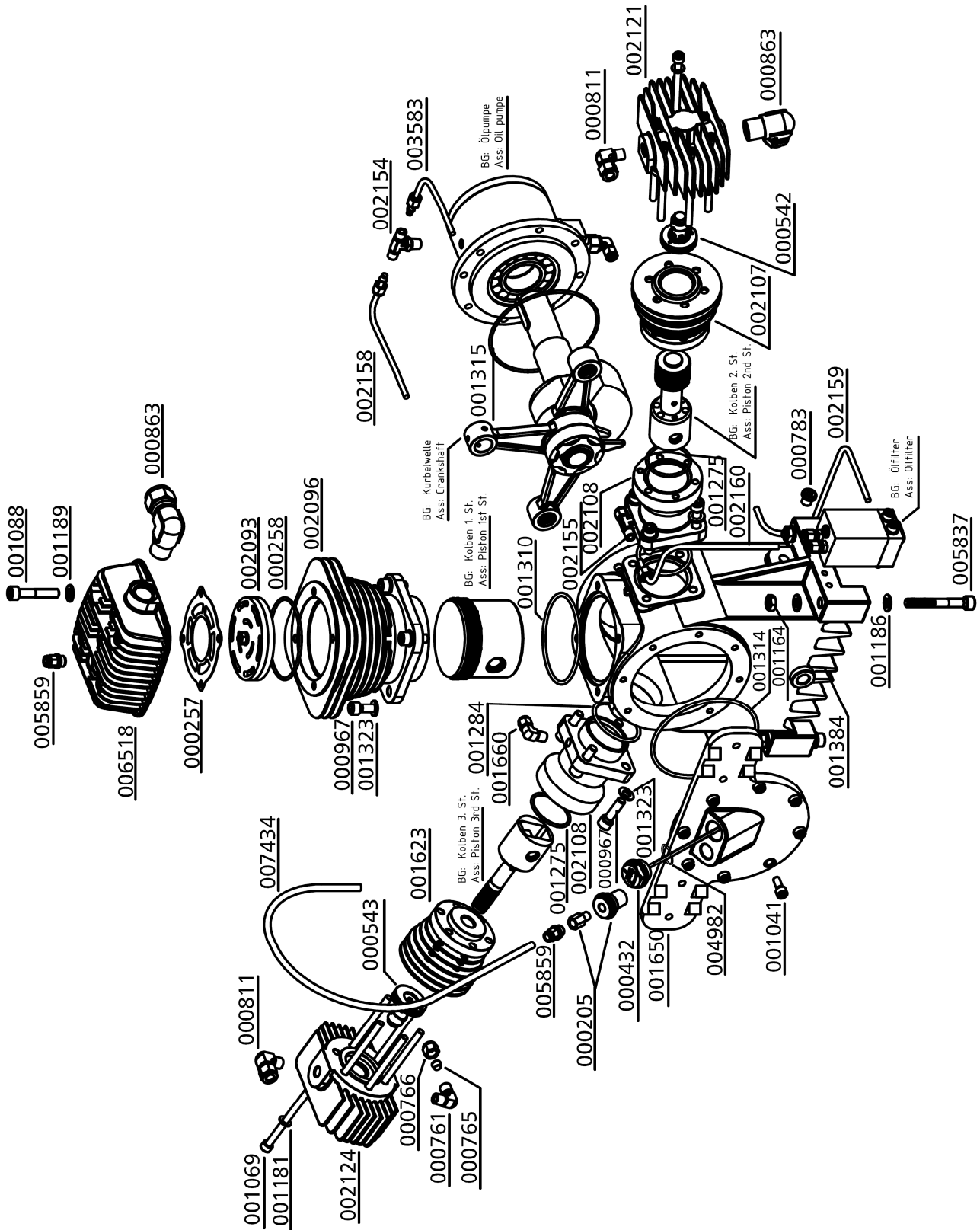



ERSATZTEILLISTE / SPARE PART LIST

Baugruppe: Wasserabscheider 1. und 2. Stufe

Assembly: Water Separator 1st and 2nd Stage

| Best.-Nr. / Order No. | Benennung | Description |
|-----------------------|--------------------------------------|--------------------------------|
| 000220 | Sicherheitsventil G3/8" | Safety Valve G3/8" 8 bar |
| 000226 | Sicherheitsventil G3/8" | Safety Valve G3/8" 60 bar |
| 000391 | U-Sit Ring, | Seal Ring U-Sit |
| 000722 | Verschraubung | Connection |
| 000733 | Schneidring | Olive Seal SR 06 (Ø 6mm) |
| 000734 | Mutter | Nut 06S |
| 000811 | Verschraubung | Elbow Connection WE3/8"/12L |
| 000837 | Verschlussstopfen | Plug |
| 000863 | Winkelverschraubung 90° | Elbow Connection |
| 001159 | Stopfmutter | Lock Nut M8 |
| 001181 | U-Scheibe A8 | Washer A8 |
| 001255 | O-Ring | O-Ring |
| 002123 | Sinterfilter G3/8" AG, 1. + 2. Stufe | Sinterfilter G3/8" 1st+2nd St. |
| 002128 | Wasserabscheider, 1. und 2. Stufe | Water separa. 1st + 2nd Stage |
| 002130 | Halter für Sinterfilter G3/8" | Holder for Sinterfilter G3/8" |
| 002150 | Haltebügel für Wasserabweiser LW280 | U-Clamp Water Separator |

DETAILANSICHT / DETAILED VIEW

Baugruppe: Wasserabscheider 1. und 2. Stufe

Assembly: Water Separator 1st and 2nd Stage

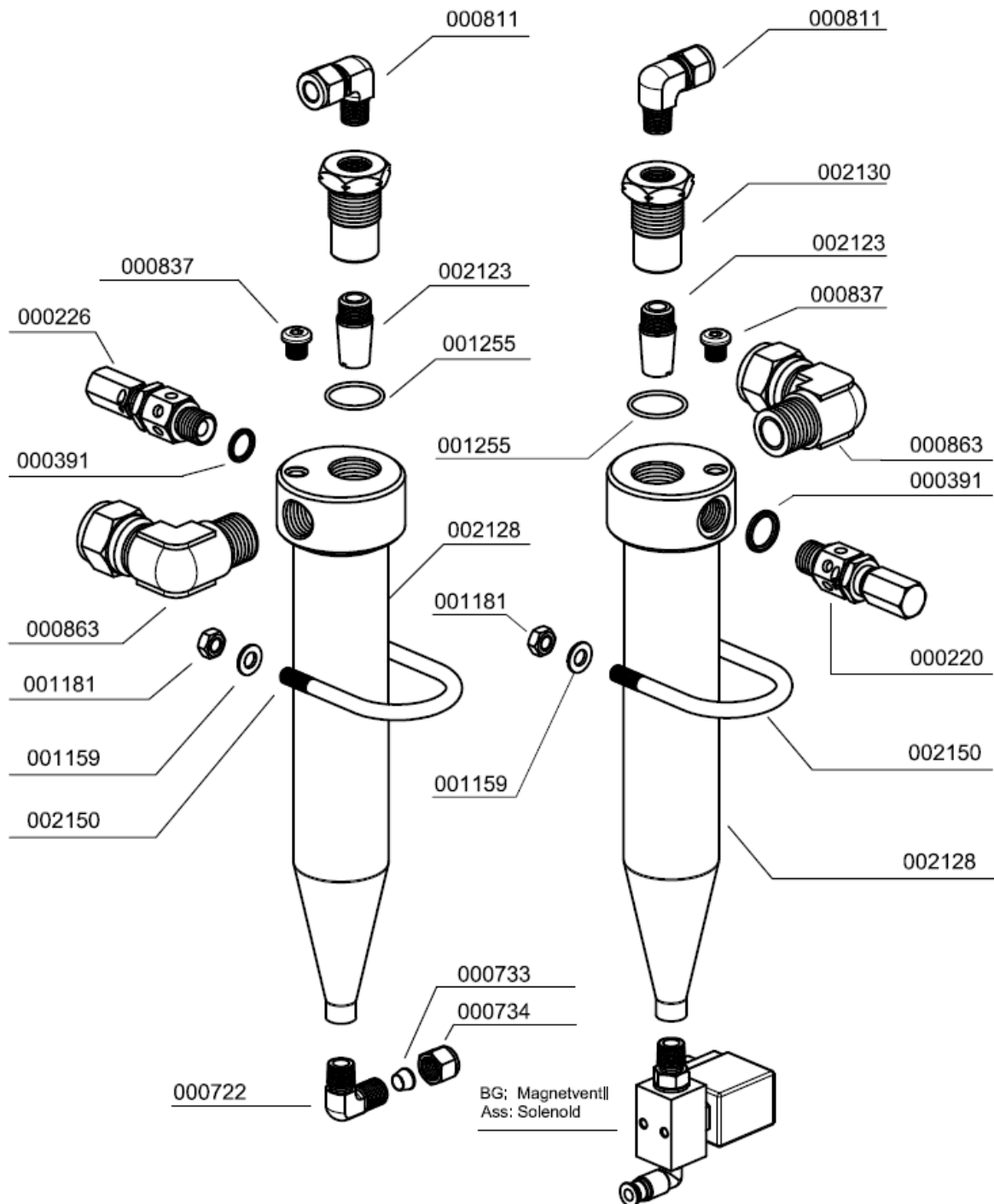

C



ERSATZTEILLISTE / SPARE PART LIST

Baugruppe: Magnetventil 2. und 3. Stufe

Assembly: Solenoid Valve 2nd and 3rd Stage

| Best.-Nr. / Order No. | Benennung | Description |
|-----------------------|---|----------------------------|
| 000892 | Doppelnippel | Double Nipple |
| 001546 | Aludichtring für Magnetventile G1/4" | Alloy Seal Ring for G1/4" |
| 005855 | Winkeleinschraubverschraubung 8 mm | Elbow Hose Connection 8 mm |
| 006113 | Magnetventil 0-55 bar | Solenoid 0-55 bar |

C

DETAILANSICHT / DETAILED VIEW

Baugruppe: Magnetventil 2. und 3. Stufe

Assembly: Solenoid Valve 2nd and 3rd Stage

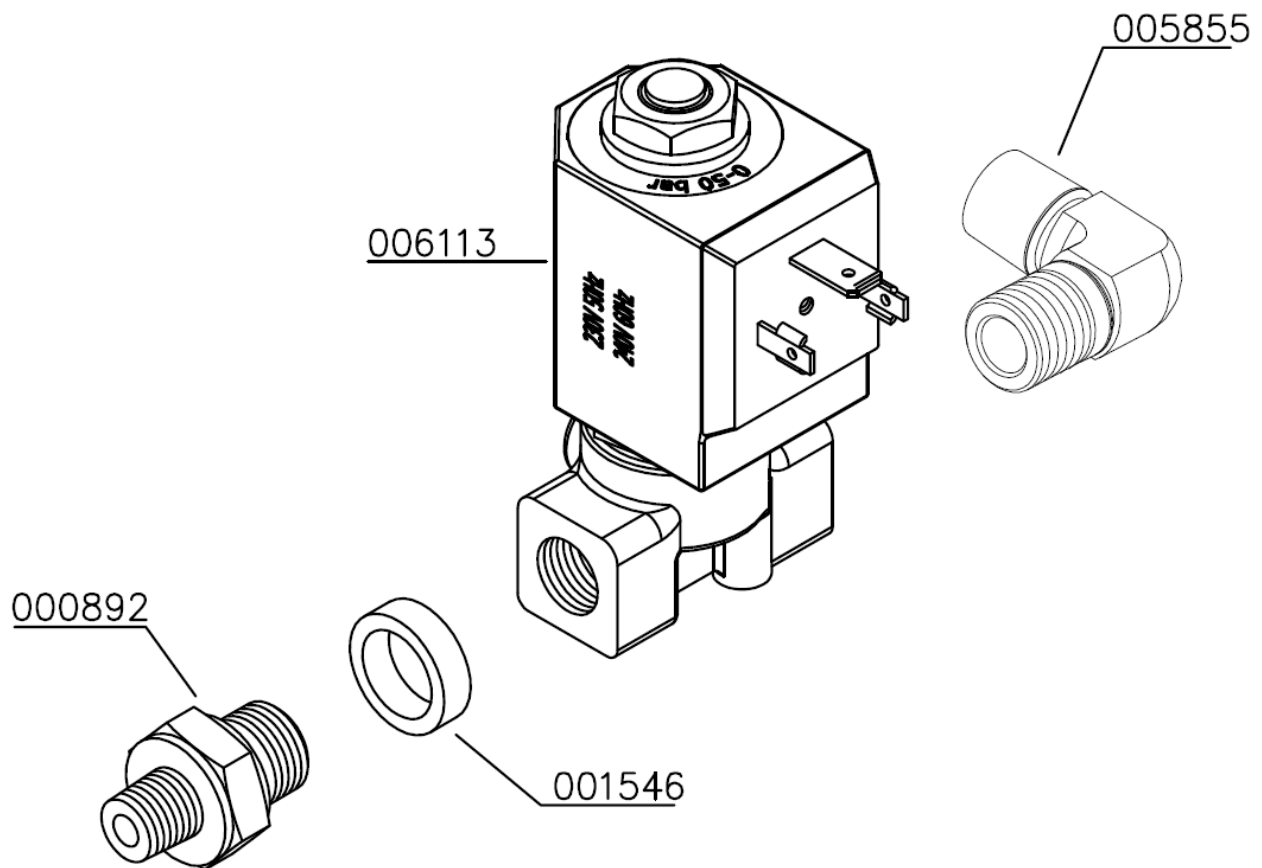

C



ERSATZTEILLISTE / SPARE PART LIST

Baugruppe: Filtergehäuse 1,7 l / Assembly: Filter housing 1.7 ltr

| Best.-Nr. / Order No. | Benennung | Description |
|-----------------------|--|--------------------------------|
| 000002 | Filterpatrone 1,7 Liter | Filter Cartridge 1.7 ltr BA |
| 000272 | Abstandshalter für Filtergehäuse | Spacer Bracket for Filtertower |
| 000383 | Messing Adapter für Filterpatrone | Brass Filter Adapter |
| 000384 | Düse für Filtergehäuse | Jet Filter Housing |
| 000738 | Verschraubung | Connection |
| 000761 | Verschraubung | Elbow Connection |
| 000765 | Schneidring | Olive Seal |
| 000766 | Mutter | Nut |
| 001160 | Hutmutter | Domed Nut M8 |
| 001181 | U-Scheibe A8 | Washer A8 |
| 001184 | Schnorr-Scheibe | Clamp Washer S8 |
| 001285 | Stützring, Filtergehäuse | Back-up Ring Filter Housing |
| 001287 | O-Ring, Filtergehäuse | O-Ring filter housing |
| 002140 | Filterschlüssel 1,7 & 2,3 Liter Behälter | Filter tool 1,7 & 2,3 Litre |
| 002147 | Haltebügel für Filtergehäuse (ES) | U-Clamp for filter housing ES |
| 002366 | Filtergehäuse | Filter housing |
| 005244 | O-Ring | O-Ring |

C

DETAILANSICHT / DETAILED VIEW

Baugruppe: Filtergehäuse 1,7 l / Assembly: Filter housing 1.7 ltr

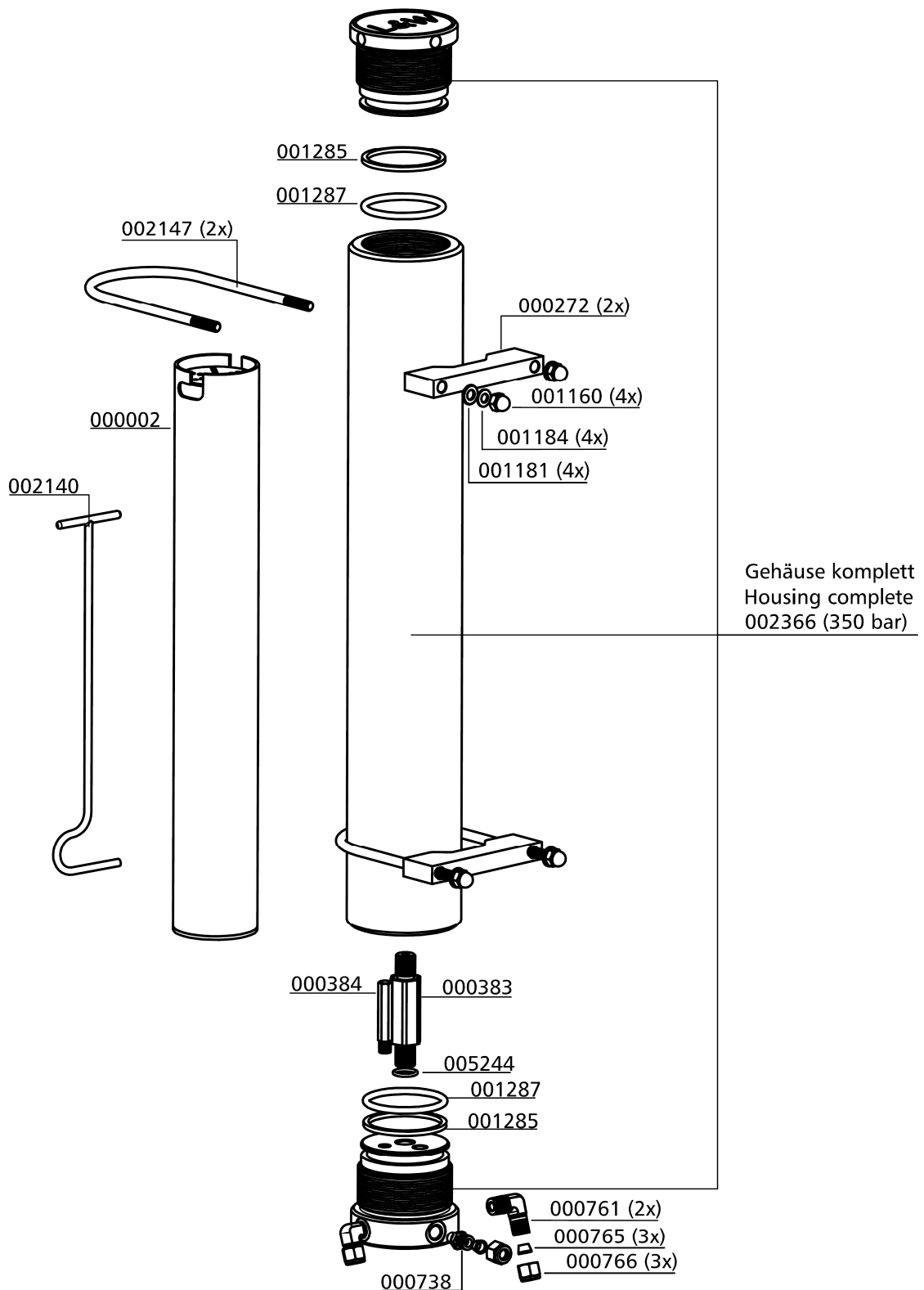

C



ERSATZTEILLISTE / SPARE PART LIST

Baugruppe: Öl- / Wasserabscheider Endstufe

Assembly: Oil- / Water Separator Final Stage

| Best.-Nr. / Order No. | Benennung | Description |
|-----------------------|--|------------------------------|
| 000175 | Deckel, Wasserabscheider | Cap, Water separator |
| 000178 | Schalldämpfer G1/2" | Silencer G1/2" |
| 000182 | Kondensatabscheider Endstufe m. Halter | Water Separator c/w bracket |
| 000183 | Wasserabweiser | Filter Protecor |
| 000184 | Sinterfilter Wasserabscheider | Siltered Filter, Oil Filter |
| 000185 | Halteteller | Plate, water separator |
| 000186 | Drallscheibe, z.B. 1. Stufe | Twist Disk, 1st. Stage |
| 000395 | Blechhalter Kondensatabscheider Endstufe | Bracket Water Separator |
| 000497 | Mutter | Nut M6 |
| 000498 | U-Scheibe A6 | Washer A6 |
| 000713 | Verschraubung | Connection |
| 000921 | Reduzierung | Reducer |
| 000948 | Flachkopfschraube | Pan Head Bolt |
| 001027 | Zylinderschraube | Allen Bolt |
| 001156 | Stopfmutter | Lock Nut M6 |
| 001294 | O-Ring Wasserabscheider, Endabscheider | O-Ring, water separator |
| 001431 | Klemmring Wasserabscheider | Lock Ring Water Separator |
| 002409 | Winkelschnellkupplung | Quick release coupling elbow |
| 002466 | Kondensatbehälter für Abscheider | Condensate bowl, |
| 002563 | Wasserabscheider Oberteil | Water Separator, Top |

C

DETAILANSICHT / DETAILED VIEW

Baugruppe: Öl- / Wasserabscheider Endstufe

Assembly: Oil- / Water Separator Final Stage

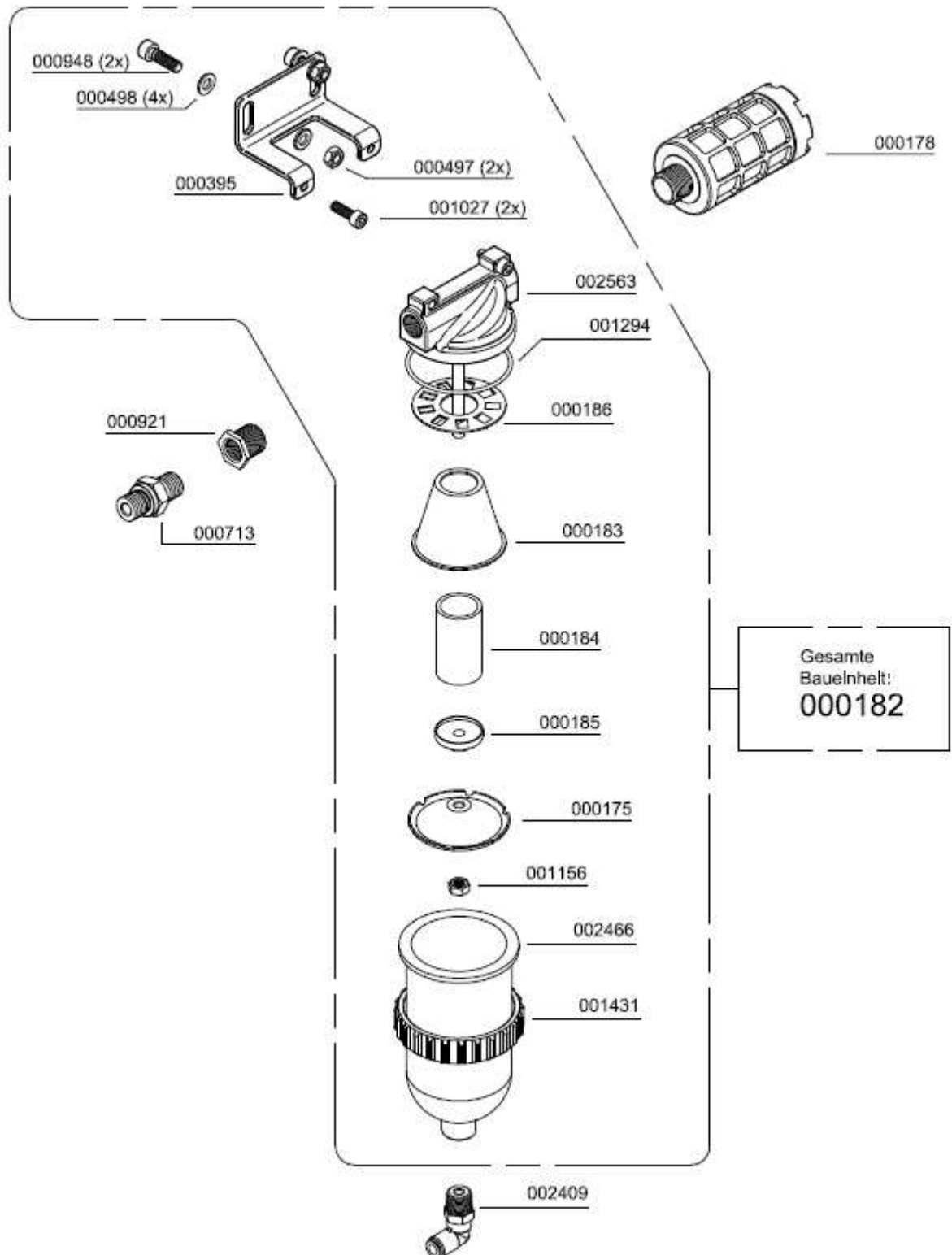

C



ERSATZTEILLISTE / SPARE PART LIST

Baugruppe: Ansaugfilter / Intake Filter

| Best.-Nr. / Order No. | Benennung | Description |
|-----------------------|--|--------------------------------|
| 000170 | Ansaugfilterpatrone | Air Intake Filter Cartridge |
| 000171 | Ansaugfiltergehäuse inkl. Patrone, kompl | Int. Filter Housing c/w filter |
| 000201 | Einschraubadapter Ansaugfilter | Adapter Inlet Filter Housing |

C

DETAILANSICHT / DETAILED VIEW

Baugruppe: Ansaugfilter / Intake Filter

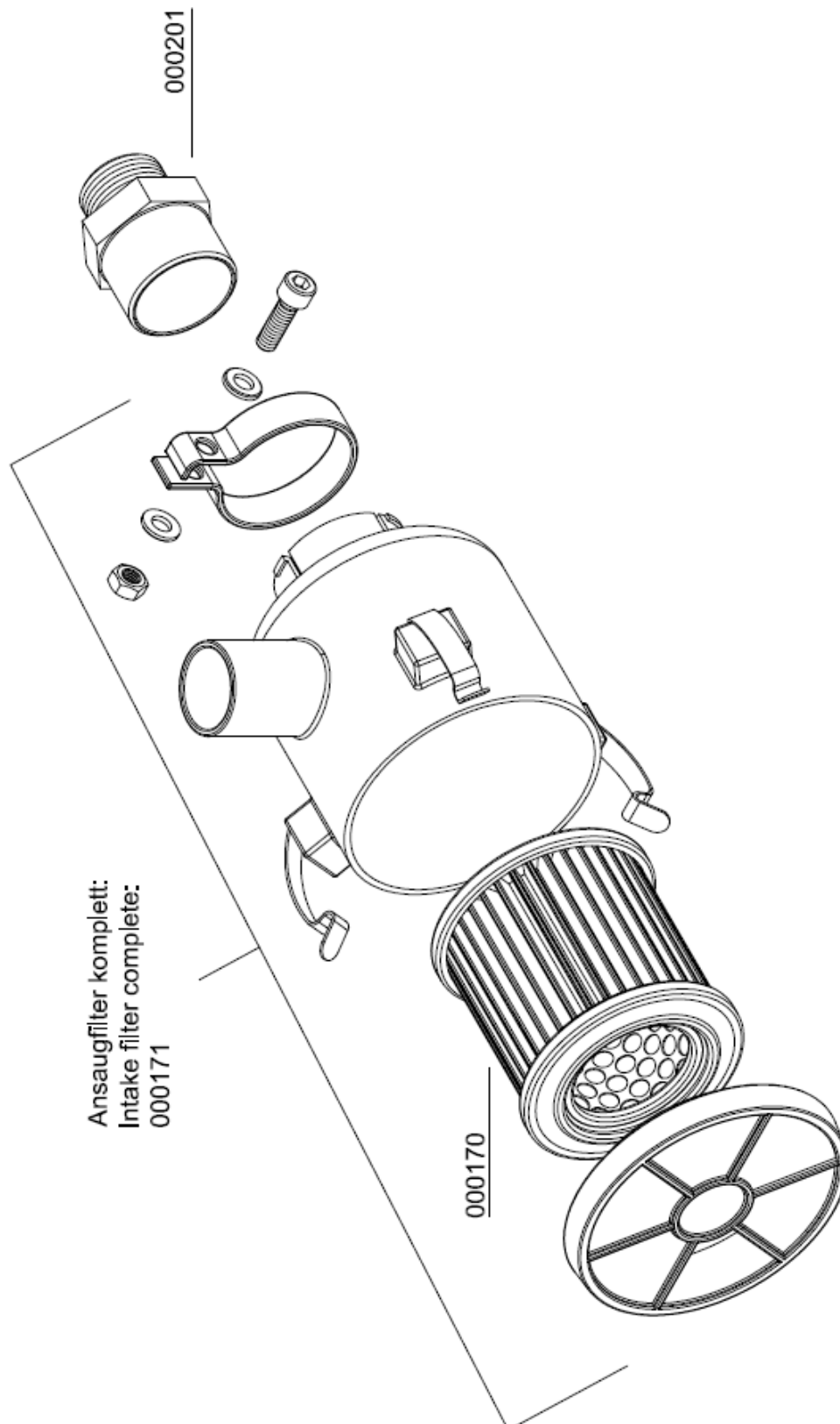

C



ERSATZTEILLISTE / SPARE PART LIST

Baugruppe: Pneumatisches Kondensatventil

Assembly: Pneumatic Condensate Valve

| Best.-Nr. / Order No. | Benennung | Description |
|-----------------------|--|-----------------------------|
| 000188 | Sinterfilter, pneum. Kondensatventil | Sintered Filter |
| 000191 | Steuerkolben, pneum. Kondensatventil | Piston |
| 000194 | Reparatursatz pneum. Kondensatventil | Repair Kit Condensate Valve |
| 000196 | Düsenschraube, pneum. Kondensatventil | Inlet Jet Screw |
| 000197 | Stopfen, pneum. Kondensatventil | Plug |
| 000198 | Gehäuse, pneum. Kondensatventil | Body PCV |
| 000199 | Pneum. Kondensatventil (Kondensatablas.) | Pneumatic Condensate Valve |
| 000498 | U-Scheibe A6 | Washer A6 |
| 000721 | Verschraubung | Connection |
| 000732 | Mutter | Union Nut 06L |
| 000733 | Schneidring | Olive Seal SR 06 (Ø 6mm) |
| 000737 | Verschraubung | Connection |
| 000738 | Verschraubung | Connection |
| 000765 | Schneidring | Olive Seal |
| 000766 | Mutter | Nut |
| 001011 | Zylinderschraube | Allen Bolt |
| 006204 | Kondensatschlauch | Condensation Drain Hose |

C

DETAILANSICHT / DETAILED VIEW

Baugruppe: Pneumatisches Kondensatventil

Assembly: Pneumatic Condensate Valve

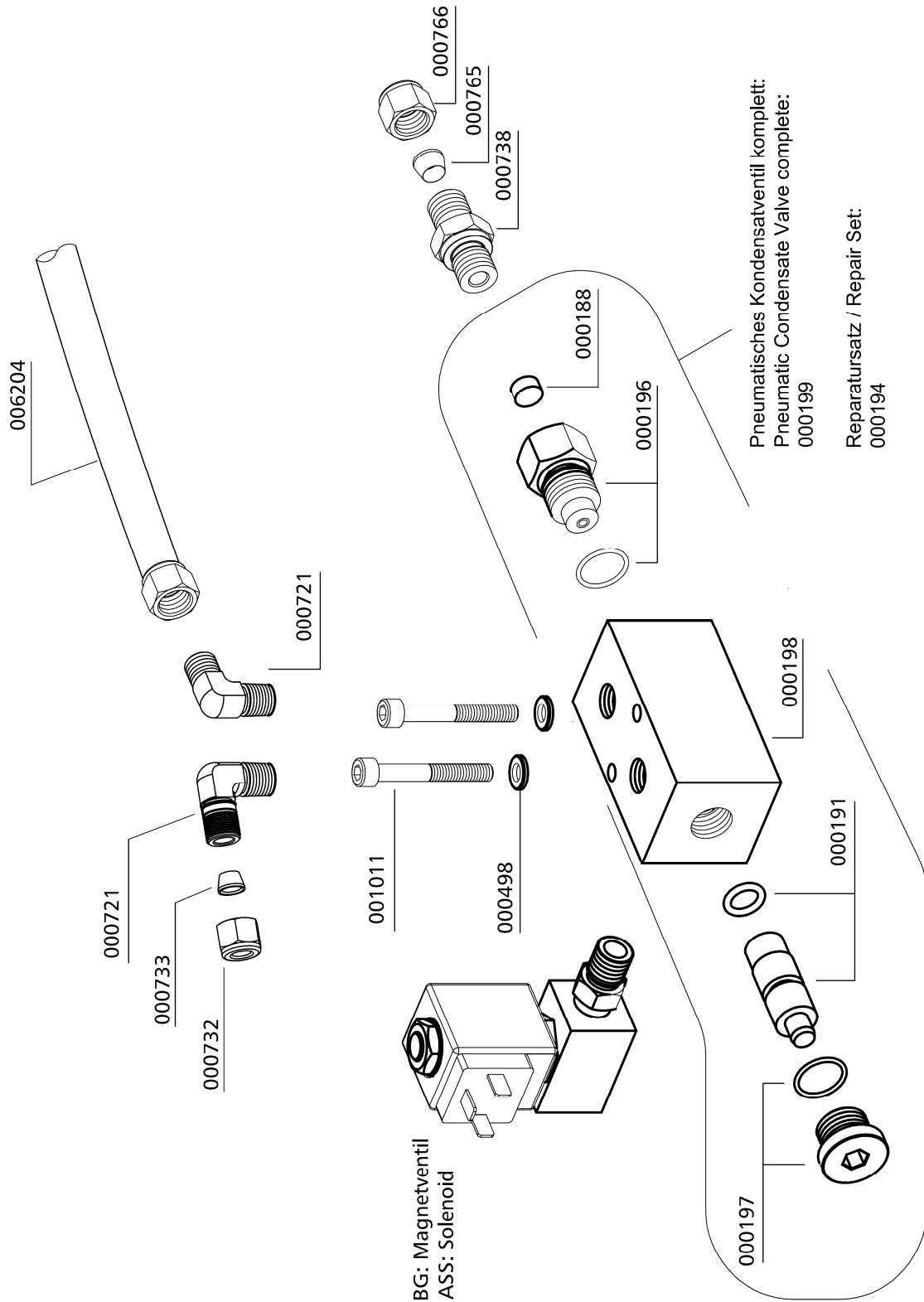



ERSATZTEILLISTE / SPARE PART LIST

Baugruppe: Sicherheitsventil / Assembly: Safety Valve

| Best.-Nr. / Order No. | Benennung | Description |
|-----------------------|---|---------------------------------|
| 000233 | Sockel für Sicherheitsventil mit TÜV/CE | Base f. Safety Valve TÜV |
| 000553 | TÜV Sicherheitsventil 225 bar | Safety Valve TÜV 225 bar |
| 000554 | TÜV Sicherheitsventil 250 bar | Safety Valve TÜV 250 bar |
| 000555 | TÜV Sicherheitsventil 300 bar | Safety Valve TÜV 300 bar |
| 000556 | TÜV Sicherheitsventil 330 bar | Safety Valve TÜV 330 bar |
| 000557 | TÜV Sicherheitsventil 350 bar | Safety Valve TÜV 350 bar |
| 000738 | Verschraubung | Connection |
| 000740 | Verschraubung | Connection |
| 000765 | Schneidring 8L | Olive 8L |
| 000766 | Mutter 8L | Nut 8L |
| 001044 | Zylinderschraube | Allen Screw |
| 001058 | Zylinderschraube | Allen Bolt |
| 001158 | Mutter | Nut |
| 001181 | Unterlegscheibe | Washer |
| 001244 | O-Ring | O-Ring, flange safety valve |
| 001814 | Sicherheitsventil - Bauteilgeprüft | Safety Valve |
| 001815 | Sicherheitsventil - Bauteilgeprüft | Safety Valve |
| 001816 | Sicherheitsventil - Bauteilgeprüft | Safety Valve |
| 001817 | Sicherheitsventil - Bauteilgeprüft | Safety Valve |
| 004428 | Hochdruckschlauch 8S - (750mm) | High Pressure Hose 8S - (750mm) |

C

ERSATZTEILLISTE / SPARE PART LIST

Baugruppe: Sicherheitsventil / Assembly: Safety Valve

| Druck | SV-Ventil mit CE-Prüfung | SV-Ventil mit TÜV-Prüfung |
|-------------|--------------------------|---------------------------|
| 225 bar | 001814 | 000553 |
| 250 bar | 001815 | 000554 |
| 285/300 bar | _____ | 000555 |
| 330 bar | 001816 | 000556 |
| 350 bar | 001817 | 000557 |

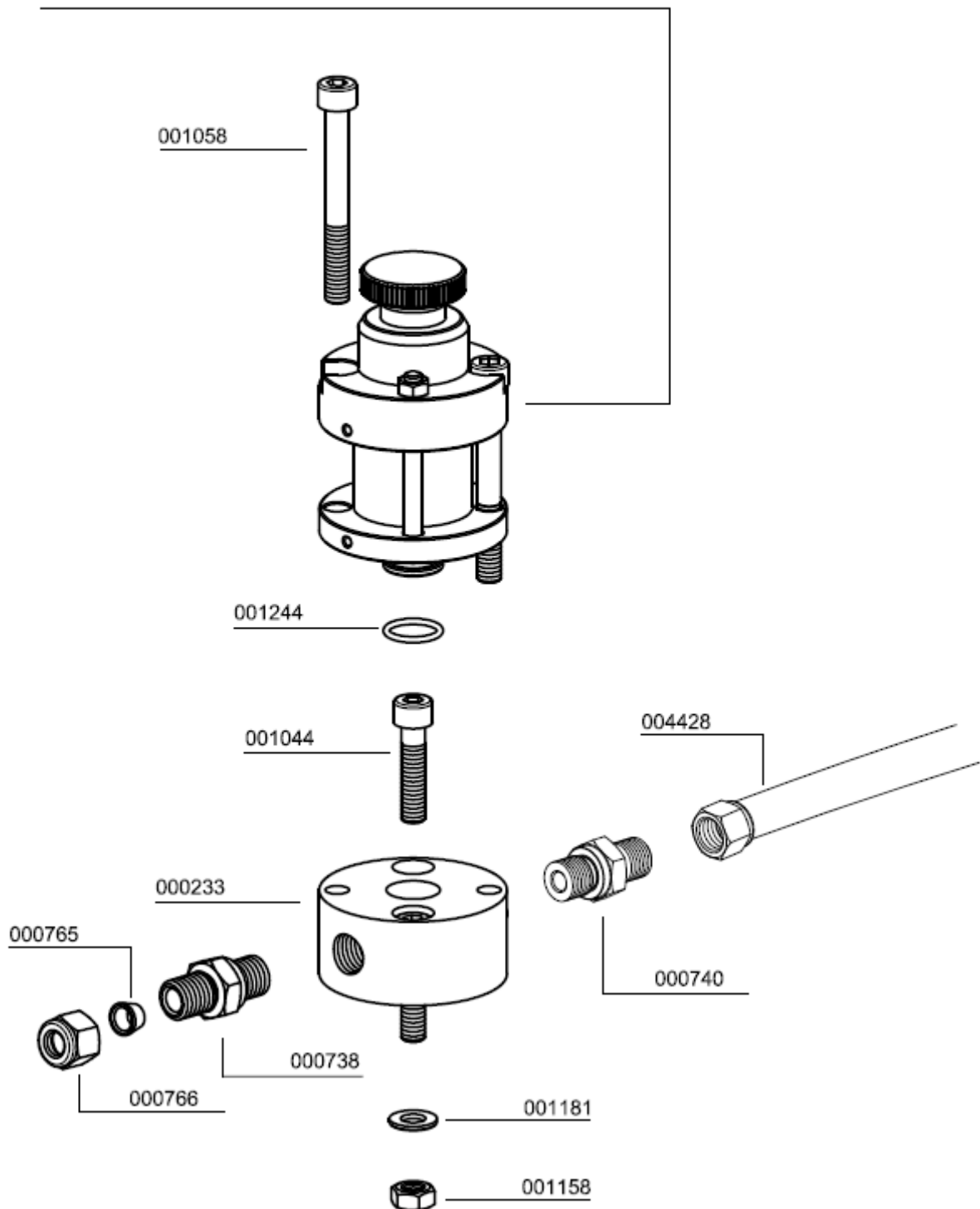

C



ERSATZTEILLISTE / SPARE PART LIST

Baugruppe: E-Motor / Assembly: E-Motor

| Best.-Nr. / Order No. | Benennung | Description |
|-----------------------|---|--------------------------------|
| 000217 | Ventilatorflansch, Zusatzlüfter | Cooling Fan Adapter Flange |
| 001040 | Zylinderschraube | Allen Screw |
| 001042 | Zylinderschraube | Allen Screw |
| 001118 | Schlossschraube | Carriage Screw |
| 001164 | Stopfmutter | Lock Nut M10 |
| 001181 | U-Scheibe A8 | Washer A8 |
| 001187 | U-Scheibe A10 | Washer A10 |
| 001209 | Passfeder | Woodruff Key |
| 001684 | Keilriemen | V-Belt |
| 001685 | Keilriemen | V-Belt |
| 002895 | Zusatzventilator Silent | Additional Fan SILENT |
| 002921 | Antriebsmotor 5,5kW 400 V | Drive motor 5,5 kW 400V |
| 003694 | Keilriemen | V-Belt |
| 003763 | Keilriemen | V-Belt |
| 003924 | Keilriemenscheibe | V-belt pulley |
| 004017 | Keilriemenscheibe Alu | V-belt pulley alloy |
| 004291 | Antriebsmotor 7,5 kW / 400 V - 50/60 Hz | Motor 7,5kW, 400V, 50-60Hz |
| 004395 | Antriebsmotor 7,5kW / 230V / 50/60 Hz | Motor, 7,5kW, 230V, 50-60 Hz |
| 006197 | Riemenscheibe | Pulley c/w bushing |
| 007101 | Keilriemenscheibe inkl. Spannbuchse | V-belt pulley for motor 7.5 kW |
| 007438 | Antriebsmotor 5,5kW 230V | Drive motor 5,5 kW 230V |
| 007443 | Keilriemenscheibe 2-rilling SPA, Alu | V-belt pulley alloy |

DETAILANSICHT / DETAILED VIEW

Baugruppe: E-Motor / Assembly: E-Motor

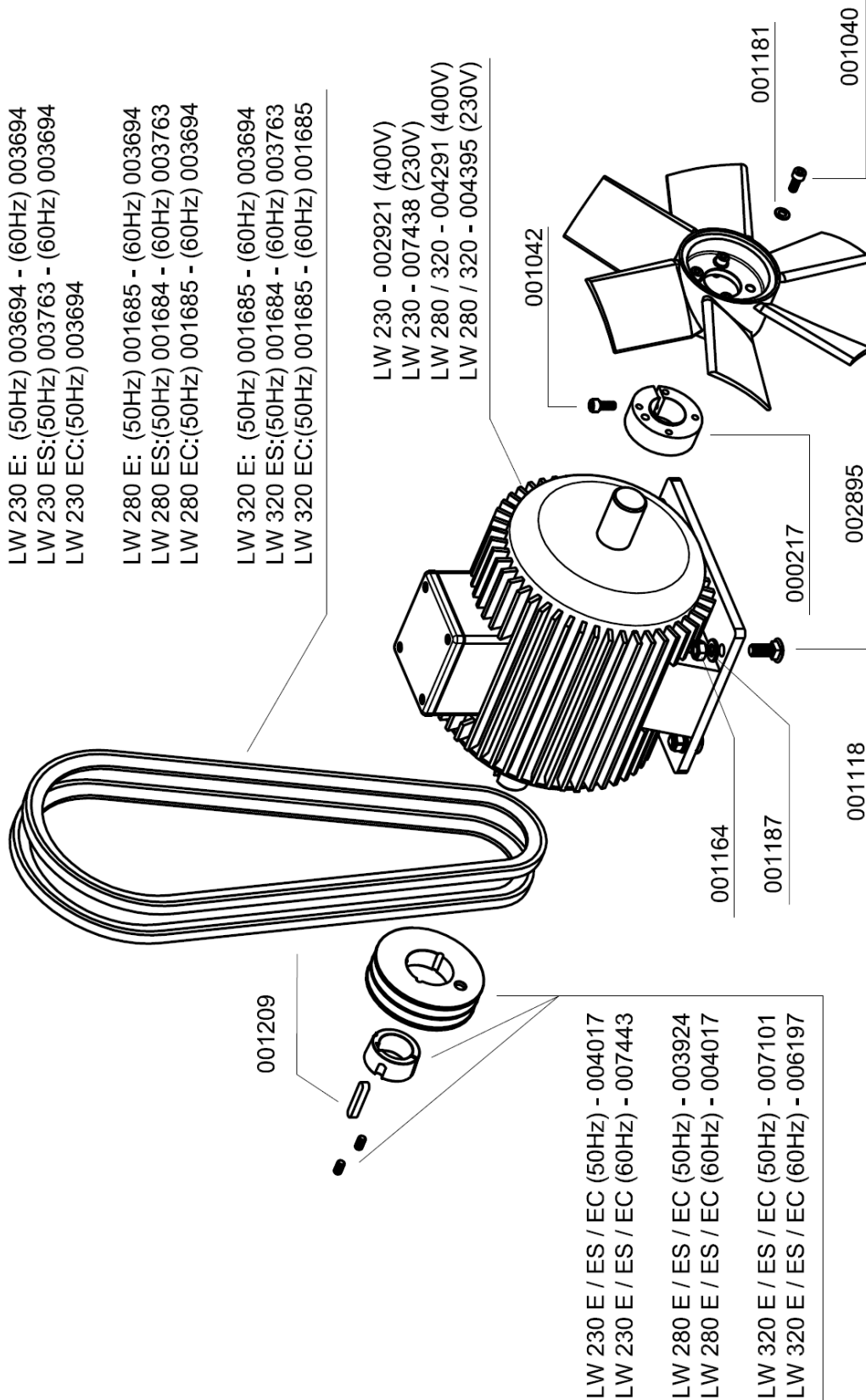



ERSATZTEILLISTE / SPARE PART LIST

Baugruppe: Druckschalter / Assembly: Pressure Switch

| Best.-Nr. / Order No. | Benennung | Description |
|-----------------------|--|--------------------------------|
| 000203 | Druckschalter, G1/4" IG, PV 50 - 350 bar | Pressure Switch 50-350 bar |
| 000749 | Verschraubung 8L | Connection with fixed nut 8L |
| 000750 | Verschraubung 8S | Connection with fixed nut 8S |
| 000757 | T-Verschraubung 8L | T-Connection with fixed nut 8L |
| 000765 | Schneidring | Olive Seal |
| 000766 | Mutter 8L | Nut 8L |
| 000767 | Mutter 8S | Union Nut 8S |
| 005043 | Verschraubung 8S | T-Connection 8S |

C

DETAILANSICHT / DETAILED VIEW

Baugruppe: Druckschalter / Assembly: Pressure Switch

000203

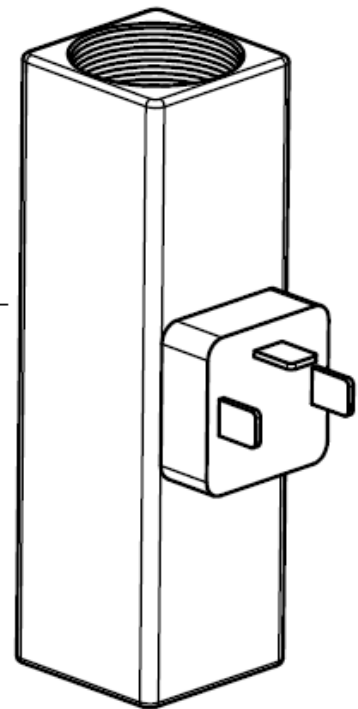

000749 (Old Version -8L)
000750 (New Version -8S)

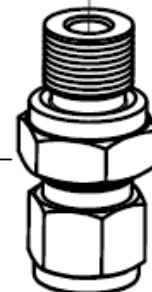

000757 (Old Version -8L)
005043 (New Version -8S)

000765

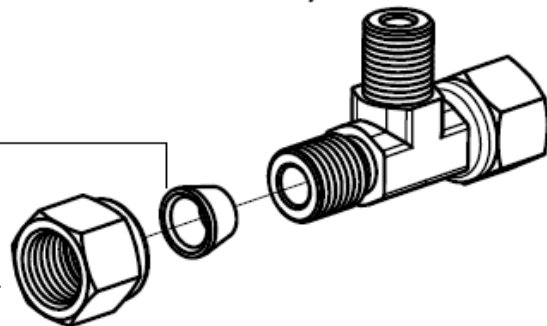

000766 (Old Version -8L)
000767 (New Version -8S)

C



ERSATZTEILLISTE / SPARE PART LIST

Baugruppe: Kolben 1. Stufe / Assembly: Piston 1st Stage

| Best.-Nr. / Order No. | Benennung | Description |
|-----------------------|--|--------------------------|
| 000265 | Kolbenringe 1. Stufe, Satz/3 Stk. | Piston Ring Set 3 pcs |
| 001356 | Sicherungsring | Circlip I22 |
| 002094 | Kolben kompl. mit Ringen,Bolzen 1. Stufe | Piston, compl. 1st Stage |
| 003900 | Kolbenbolzen, 1. Stufe | Piston pin, 1st stage |

C

DETAILANSICHT / DETAILED VIEW

Baugruppe: Kolben 1. Stufe / Assembly: Piston 1st Stage

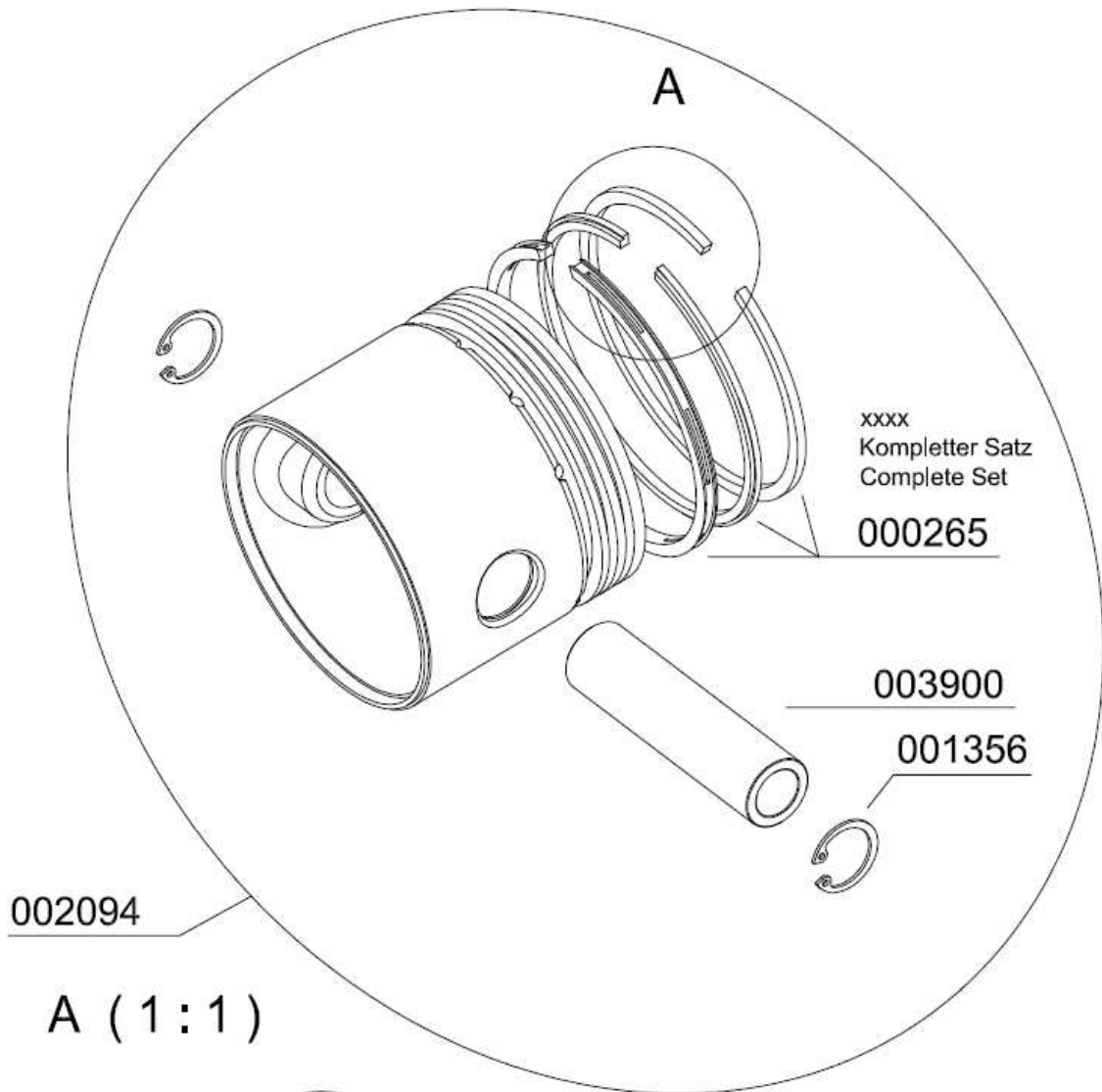

C

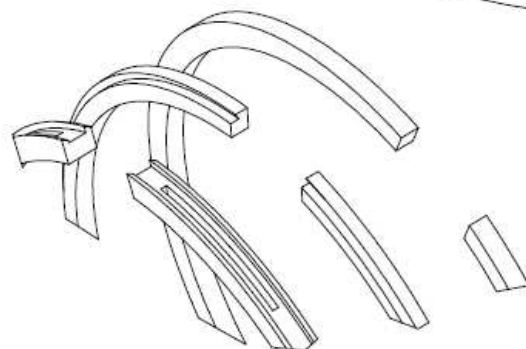



ERSATZTEILLISTE / SPARE PART LIST

Baugruppe: Kolben 2. Stufe / Assembly: Piston 2nd Stage

| Best.-Nr. / Order No. | Benennung | Description |
|-----------------------|---|-------------------------------|
| 001353 | Sicherungsring | Circlip I16 |
| 002109 | Kolben 2. Stufe, kompl. mit Kolbenringe | Piston (c/w) rings 2nd Stage |
| 002122 | Kolbenbolzen, 2. + 3. Stufe | Piston pin, 2nd + 3rd Stage |
| 002805 | Kolbenringe 2. Stufe Satz | Set of piston rings 2nd stage |
| 002948 | Führungskolben 2. / 3. Stufe | Guide piston 2nd + 3rd stage |

C

DETAILANSICHT / DETAILED VIEW

Baugruppe: Kolben 2. Stufe / Assembly: Piston 2nd Stage

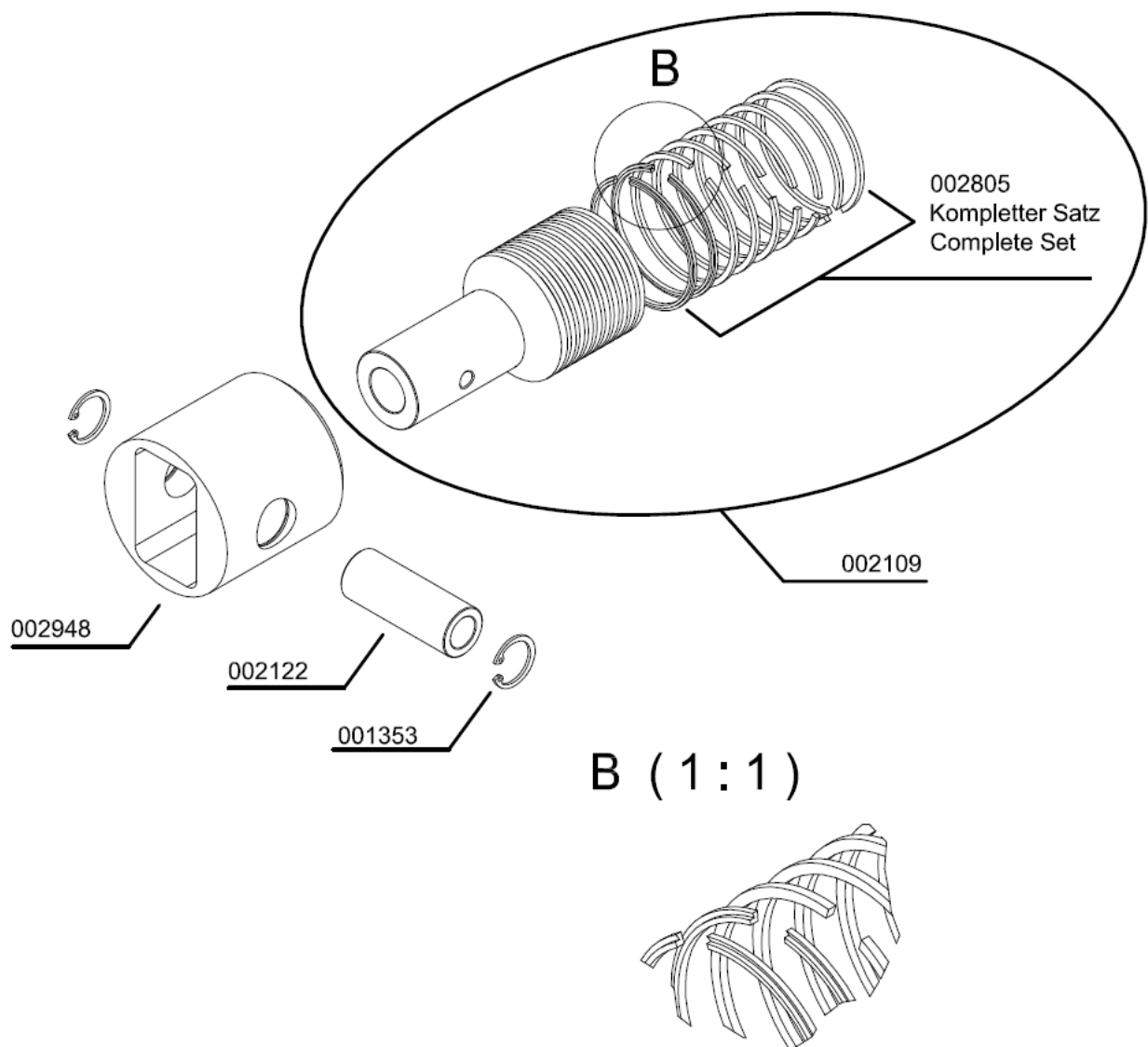

C



ERSATZTEILLISTE / SPARE PART LIST

Baugruppe: Kolben 3. Stufe / Assembly: Piston 3rd Stage

| Best.-Nr. / Order No. | Benennung | Description |
|-----------------------|------------------------------------|------------------------------|
| 001353 | Sicherungsring | Circlip I16 |
| 002122 | Kolbenbolzen, 2. + 3. Stufe | Piston pin, 2nd + 3rd Stage |
| 002125 | Kolben inkl. Kolbenringe, 3. Stufe | Piston c/w rings 3rd Stage |
| 002324 | Kolbenringe 3. Stufe Satz/9Stk. | Piston rings, 3rd Stage |
| 002948 | Führungskolben 2. / 3. Stufe | Guide piston 2nd + 3rd stage |

C

DETAILANSICHT / DETAILED VIEW

Baugruppe: Kolben 3. Stufe / Assembly: Piston 3rd Stage

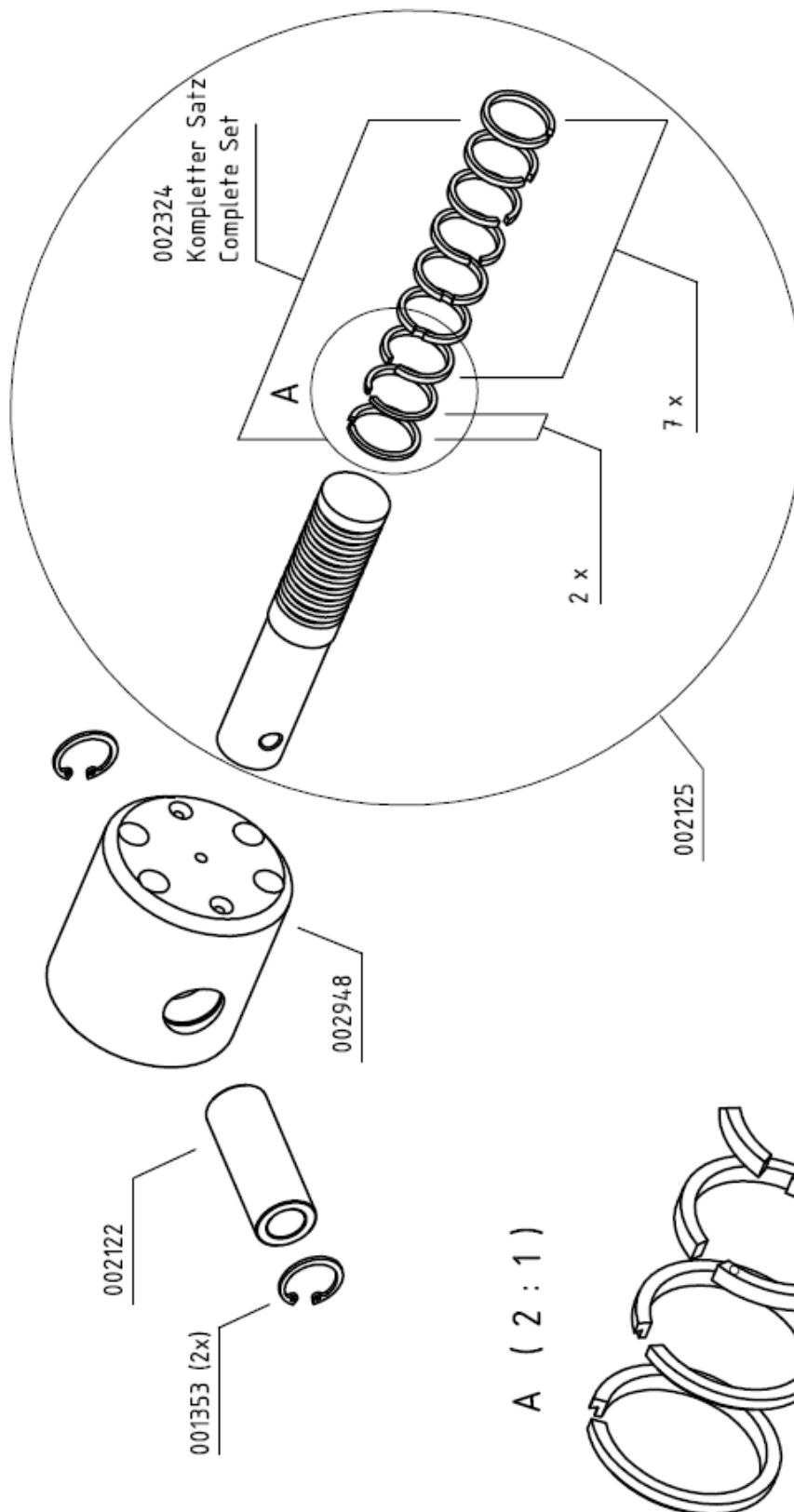

C



ERSATZTEILLISTE / SPARE PART LIST

Baugruppe: Kurbelwelle / Assembly: Crankshaft

| Best.-Nr. / Order No. | Benennung | Description |
|-----------------------|-------------------------------------|------------------------------|
| 001209 | Passfeder | Woodruff Key |
| 001304 | Anlaufscheibe vordere (sternförmig) | Thrust Washer, Star shaped |
| 001308 | Anlaufscheibe hintere | Thrust Washer - rear side |
| 001343 | Sicherungsring | Circlip A35 |
| 001503 | Kurbelwelle | Crank Shaft |
| 001673 | Pleuel 2.+3. Stufe | Connecting Rod 2nd/3rd Stage |
| 001674 | Pleuel 1. Stufe | Connecting Rod 1st Stage |
| 002149 | Pleuellager oberes | Small end bearing |
| 002164 | Pleuellager unteres | Big end bearing |

C

DETAILANSICHT / DETAILED VIEW

Baugruppe: Kurbelwelle / Assembly: Crankshaft

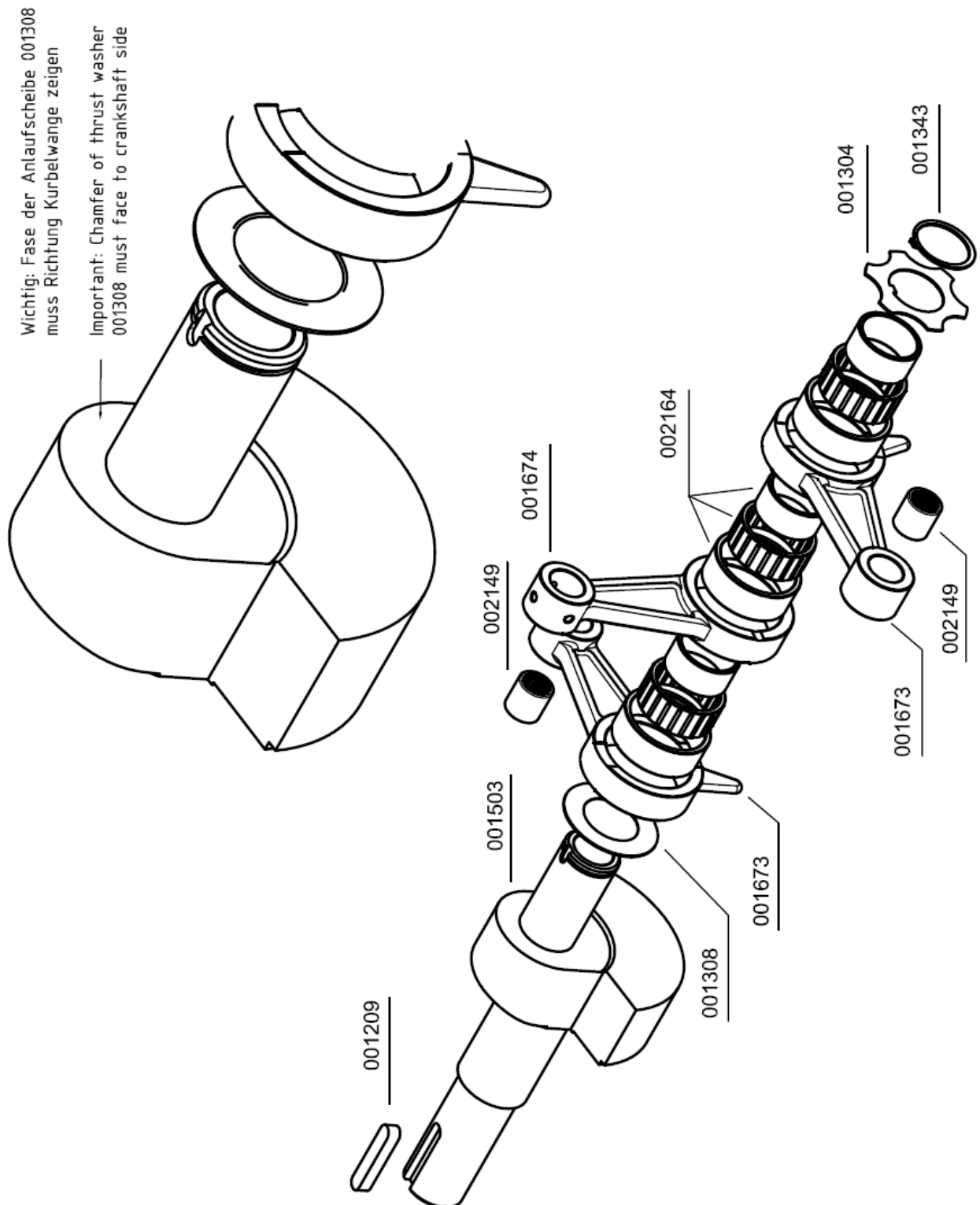



ERSATZTEILLISTE / SPARE PART LIST

Baugruppe: Kühlrohre / Assembly: Cooling Pipes

| Best.-Nr. / Order No. | Benennung | Description |
|-----------------------|----------------------------|-------------------------------|
| 001037 | Schlossschraube | Carriage Bolt |
| 001042 | Zylinderschraube | Allen Screw |
| 001181 | U-Scheibe A8 | Washer A8 |
| 002067 | Kühlrohr 3. Stufe (E / ES) | Cooling pipe 3rd Stage (E/ES) |
| 002343 | Kühlrohr-Haltearm | Cooling pipe, bracket s/s |
| 002344 | Kühlrohr-Halteplatte | Plate |
| 002345 | Kühlrohr-Oberplatte | Upper plate |
| 002346 | Kühlrohr Klemmdeckel | Cooling pipe bracket cap |
| 003271 | Kühlspirale 1. Stufe | Cooling coil, 1st stage |
| 003576 | Kühlspirale, 2. Stufe | Cooling coil, 2nd stage |

C

DETAILANSICHT / DETAILED VIEW

Baugruppe: Kühlrohre / Assembly: Cooling Pipes

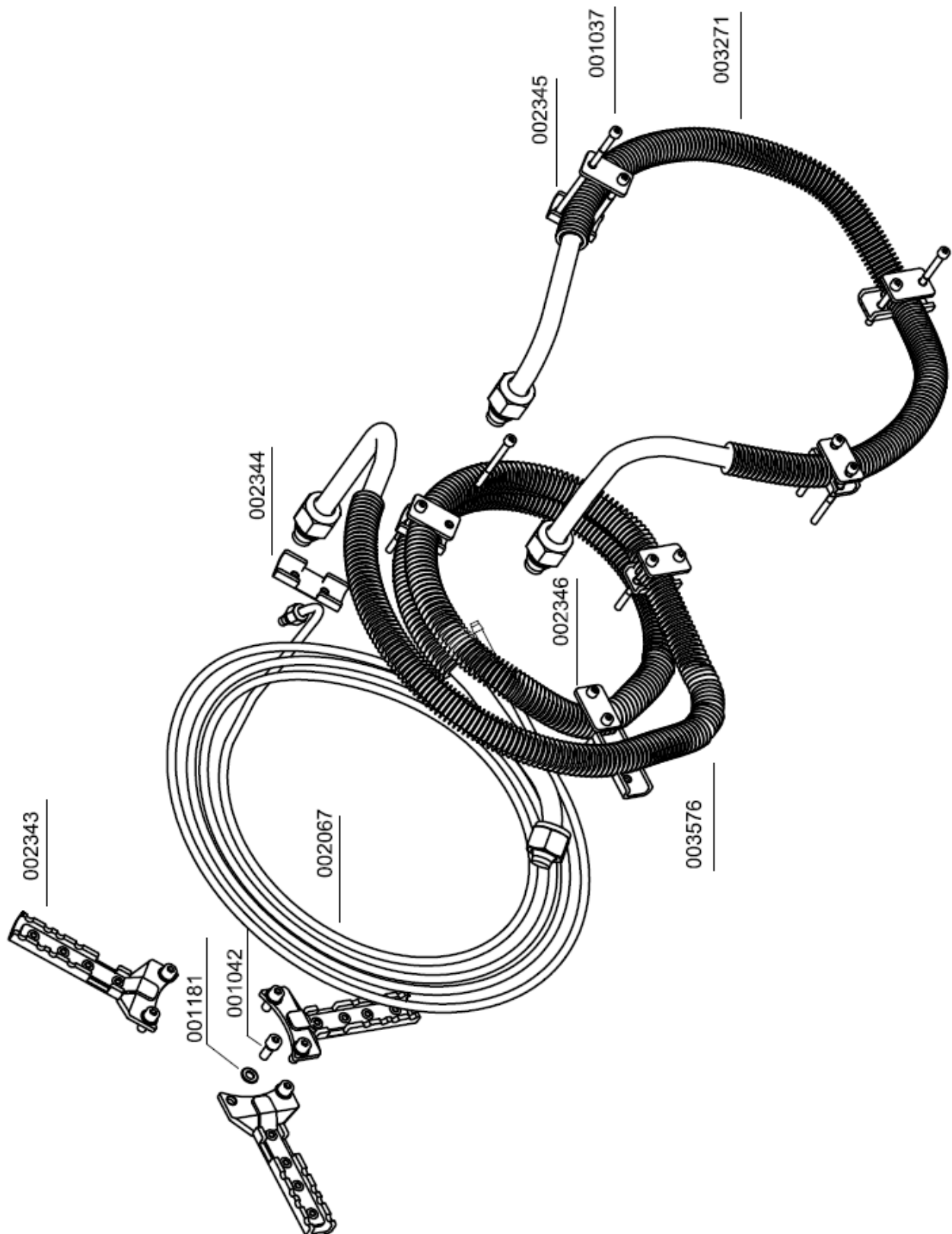

C



ERSATZTEILLISTE / SPARE PART LIST

Kühlrohr 3. Stufe / Cooler 3rd Stage

| Best.-Nr. / Order No. | Benennung | Description |
|-----------------------|------------------------------------|------------------------------------|
| 000735 | Verschraubung, G08LCFX | Connection, G08LCFX |
| 001043 | Zylinderschraube, M8x35mm DIN912 | Allen Screw, M8x35mm DIN912 8.8 ZN |
| 001181 | U-Scheibe A8 DIN125 ZN | Washer A8 |
| 003509 | Kühlspirale 3. Stufe | Cooler 3rd Stage |
| 007372 | Klemmschiene Wärmetauscher, | Metal Bar for Cooler, 160 mm |
| 007373 | PVC Schlauch für Kühlwendelhalter, | PVC Hose for Bracket, 160 mm |

C

DETAILANSICHT / DETAILED VIEW

Kühlrohr 3. Stufe / Cooler 3rd Stage

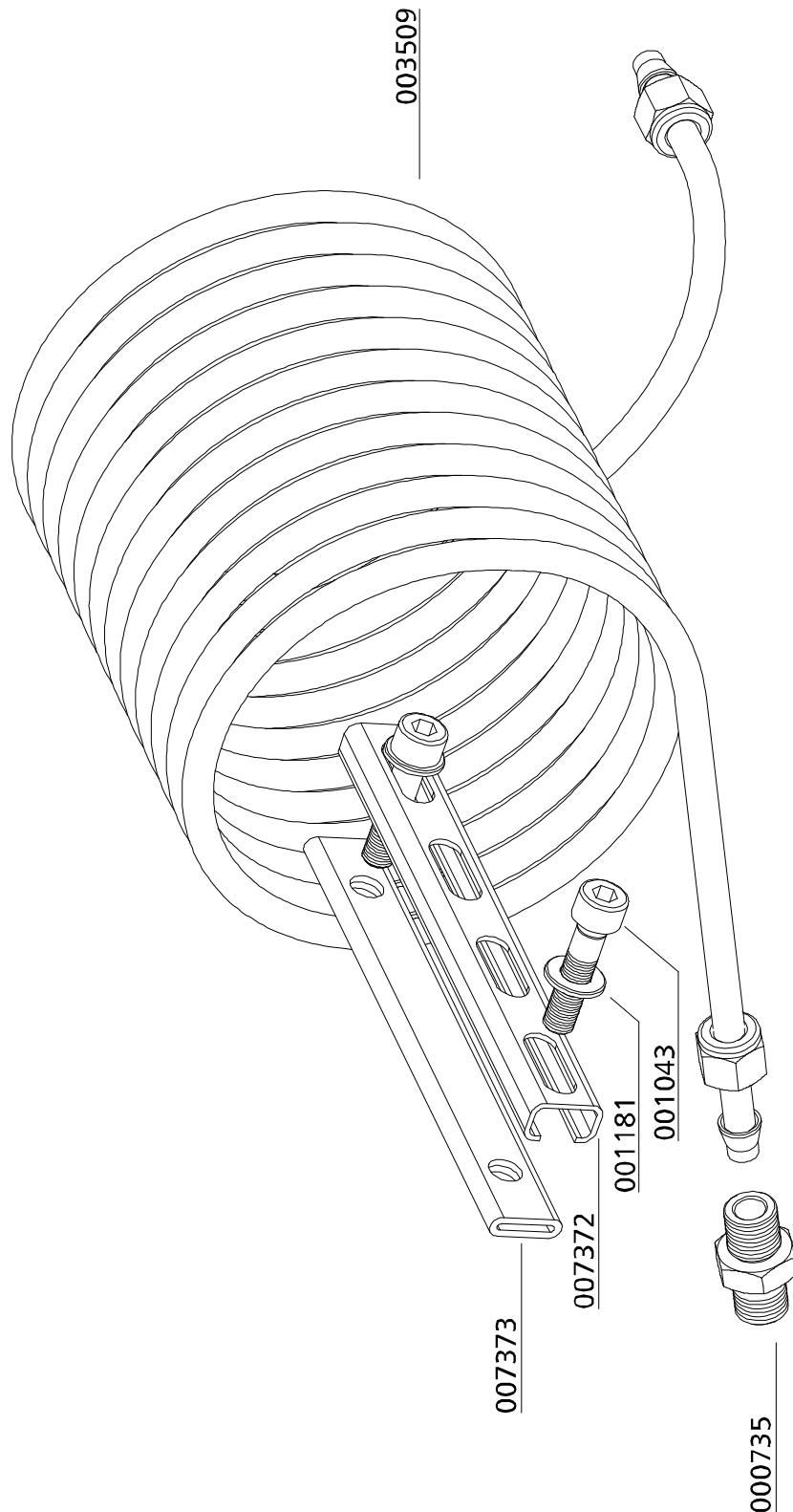

C



ERSATZTEILLISTE / SPARE PART LIST

Baugruppe: Zusatzkühler / Assembly: Additional Cooler

| Best.-Nr. / Order No. | Benennung | Description |
|-----------------------|--------------------------------|----------------------------|
| 000499 | Zylinderschraube | Bolt |
| 000628 | Einfachselle 1 x 8mm 1 Paar | Pipe Clamp 1x8mm 1pair PVC |
| 000638 | Doppelschelle 2 x 8 mm 1 Paar | Pipe Clamp 2x8mm - 1 pair |
| 000735 | Verschraubung | Connection |
| 000765 | Schneidring | Olive Seal |
| 000766 | Mutter | Nut |
| 001013 | Zylinderschraube | Allen Bolt |
| 002344 | Kühlrohr-Halteplatte | Plate |
| 006544 | Nietröllchen | Spacer for threaded Rivet |
| 007795 | Zusatzkühler, 3. Stufe, kompl. | Additional cooler |

C

DETAILANSICHT / DETAILED VIEW

Baugruppe: Zusatzkühler / Assembly: Additional Cooler

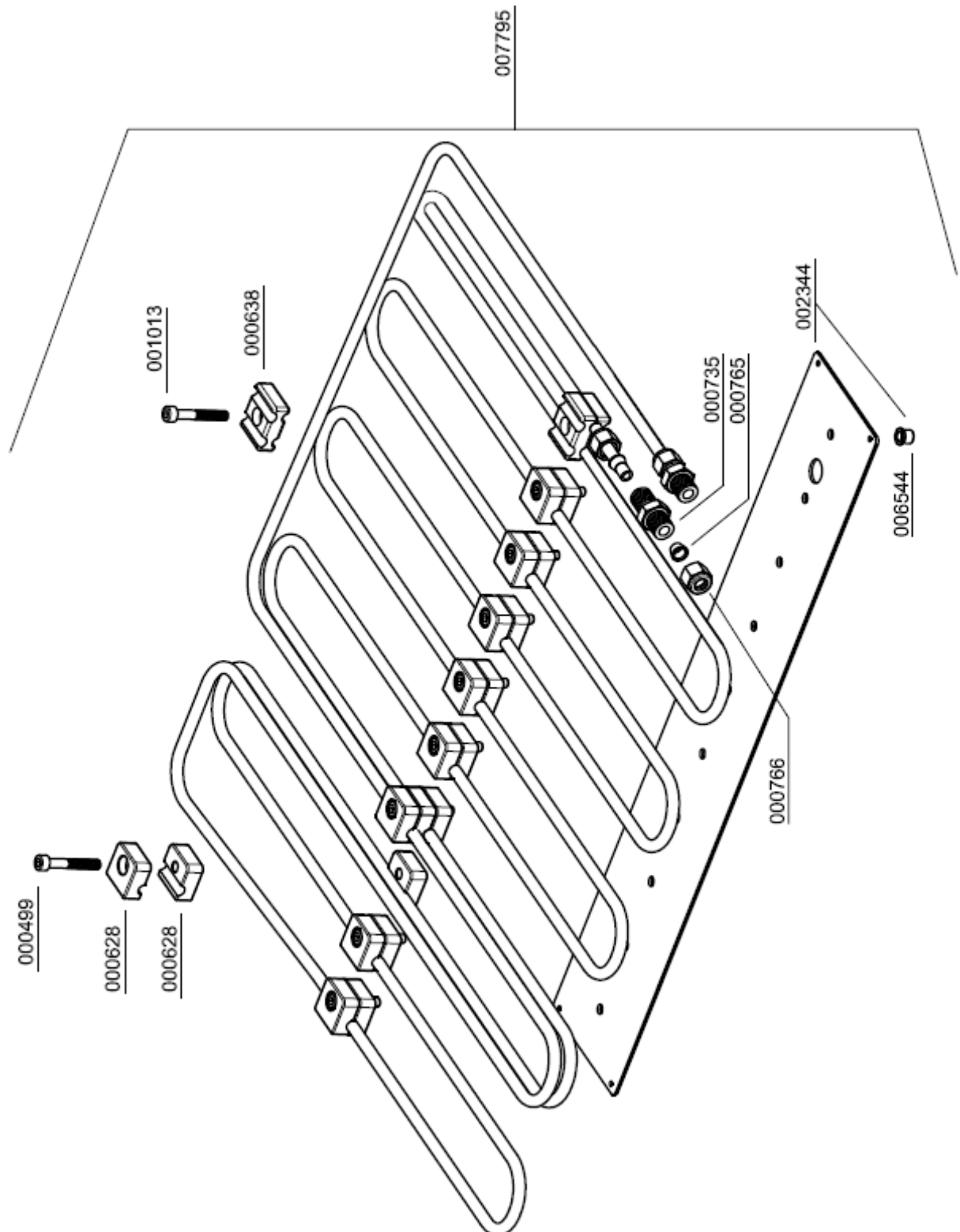

C



ERSATZTEILLISTE / SPARE PART LIST

Baugruppe: Lüfterrad / Assembly: Fan Wheel

| Best.-Nr. / Order No. | Benennung | Description |
|-----------------------|---|-------------------------------|
| 000498 | U-Scheibe A6 | Washer A6 |
| 001026 | Zylinderschraube | Allen Bolt |
| 002335 | Ventilatorflügelblatt, schwarz | Fan blade, black, new version |
| 002336 | Haltering Ventilatorflügel | Fan blade holder |
| 003273 | Schwungrad, inkl. Schrauben & Haltering | Flywheel c/w bolts & clamping |

C

DETAILANSICHT / DETAILED VIEW

Baugruppe: Lüfterrad / Assembly: Fan Wheel

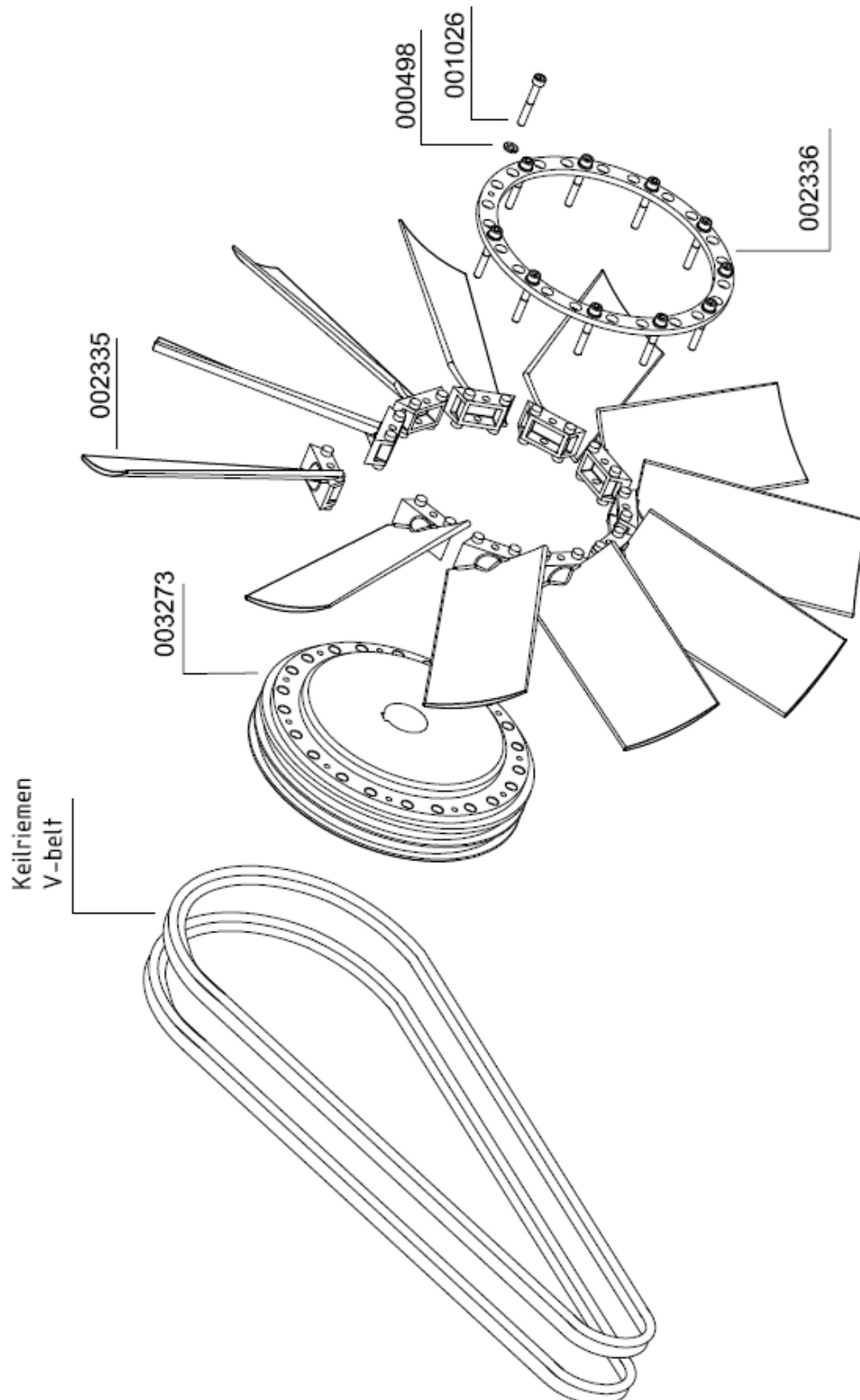

C



ERSATZTEILLISTE / SPARE PART LIST

Baugruppe: E-Motor / Assembly: E-Motor

| Best.-Nr. / Order No. | Benennung | Description |
|-----------------------|---|--------------------------------|
| 000148 | Keilriemen | V-Belt |
| 000217 | Ventilatorflansch, Zusatzlüfter | Cooling Fan Adapter Flange |
| 001040 | Zylinderschraube | Allen Screw |
| 001042 | Zylinderschraube | Allen Screw |
| 001118 | Schlossschraube | Carriage Screw |
| 001164 | Stopfmutter | Lock Nut M10 |
| 001181 | U-Scheibe A8 | Washer A8 |
| 001187 | U-Scheibe A10 | Washer A10 |
| 001209 | Passfeder | Woodruff Key |
| 001684 | Keilriemen | V-Belt |
| 001685 | Keilriemen | V-Belt |
| 002895 | Zusatzventilator Silent | Additional Fan SILENT |
| 002921 | Antriebsmotor 5,5kW 400 V | Drive motor 5,5 kW 400V |
| 003694 | Keilriemen | V-Belt |
| 003763 | Keilriemen | V-Belt |
| 003924 | Keilriemenscheibe | V-belt pulley |
| 004017 | Keilriemenscheibe Alu | V-belt pulley alloy |
| 004291 | Antriebsmotor 7,5 kW / 400 V - 50/60 Hz | Motor 7,5kW, 400V, 50-60Hz |
| 004395 | Antriebsmotor 7,5kW / 230V / 50/60 Hz | Motor, 7,5kW, 230V, 50-60 Hz |
| 006197 | Riemenscheibe | Pulley c/w bushing |
| 007101 | Keilriemenscheibe inkl. Spannbuchse | V-belt pulley for motor 7.5 kW |
| 007438 | Antriebsmotor 5,5kW 230V | Drive motor 5,5 kW 230V |
| 007443 | Keilriemenscheibe 2-rilling SPA, Alu | V-belt pulley alloy |

C

DETAILANSICHT / DETAILED VIEW

Baugruppe: E-Motor / Assembly: E-Motor

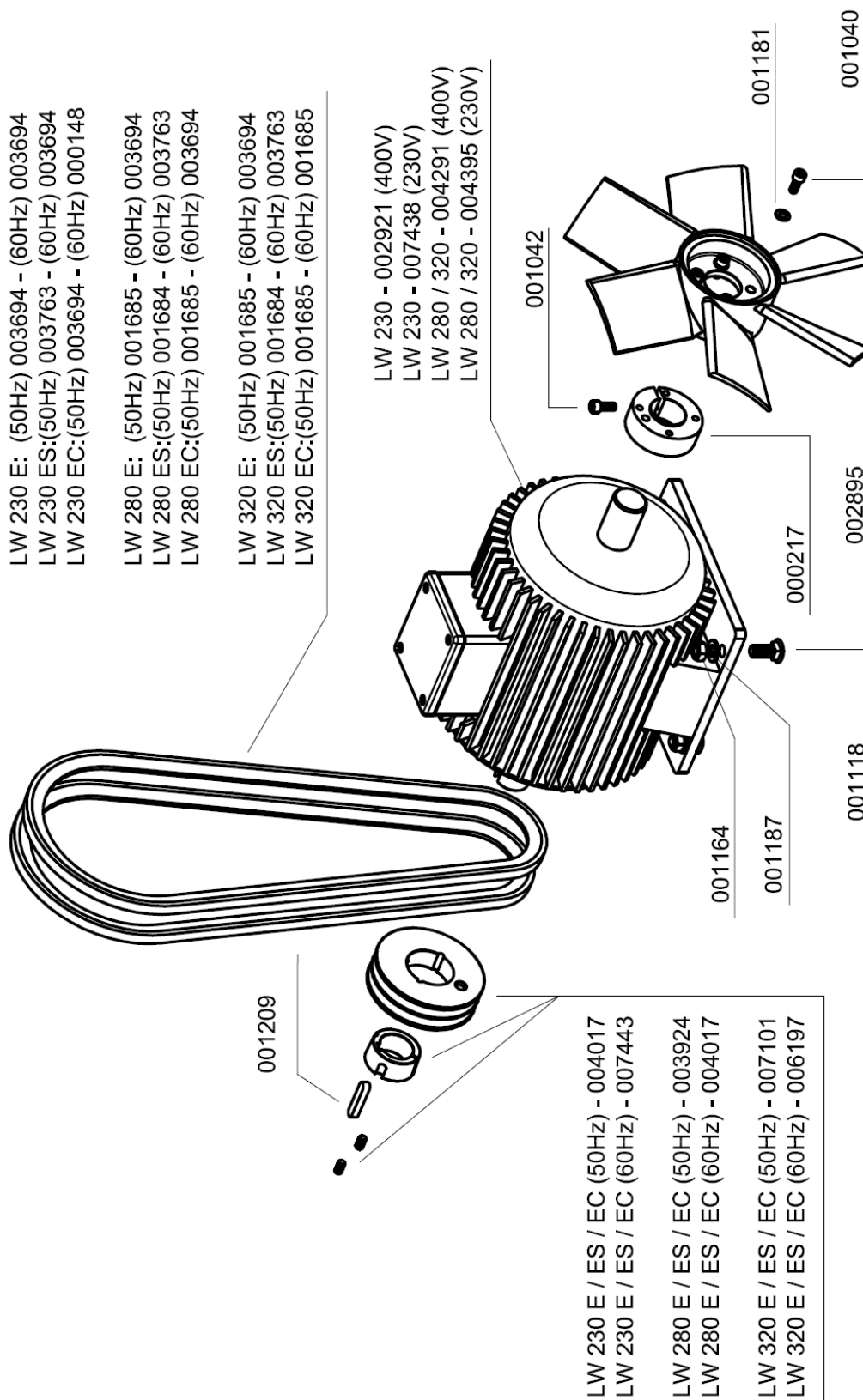

ERSATZTEILLISTE / SPARE PART LIST

Baugruppe: Saug und Druckventil 1. Stufe /

Assembly: In and outlet valve 1st stage

| Best.-Nr. / Order No. | Benennung | Description |
|-----------------------|--------------------------------|-----------------------------|
| 002093 | Saug-und Druckventil, 1. Stufe | In & Outlet Valve 1st Stage |

C

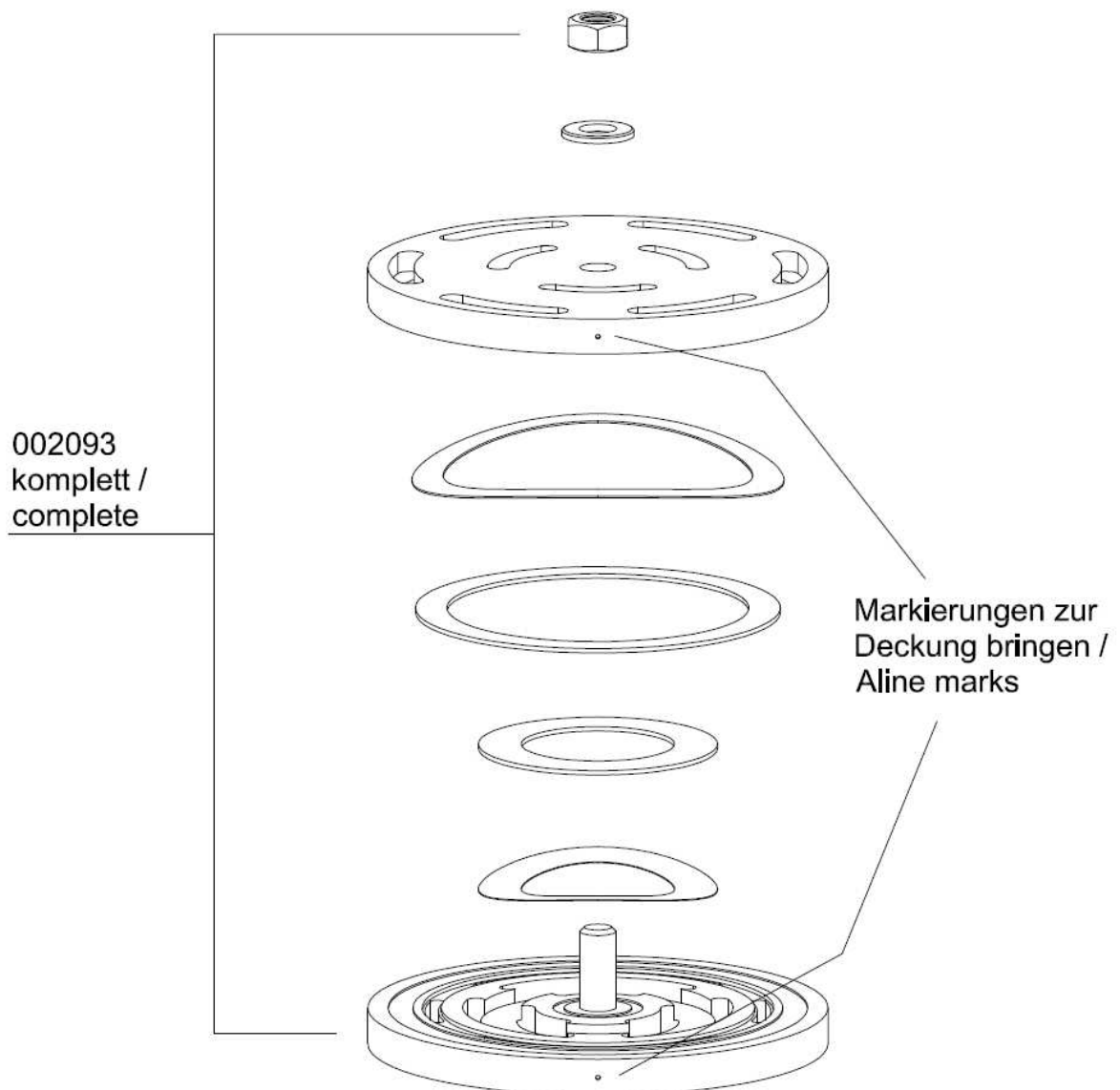

ERSATZTEILLISTE / SPARE PART LIST

Baugruppe: Saug und Druckventile 2. und 3. Stufe /

Assembly: In and outlet valves 2nd and 3rd stage

| Best.-Nr. / Order No. | Benennung | Description |
|-----------------------|---|-------------------------------|
| 000528 | Ventildichtung, Saug- & Druckventil unten | Lower Valve Gasket, 3rd St. |
| 000529 | Ventildichtung, Saug- & Druckventil unten | Lower Valve Gasket, 2nd St. |
| 000541 | Dichtring / Dichtung Ventil | Upper Alloy Seal Ring |
| 000542 | Saug- & Druckventil, 2. Stufe komplett | In- & Outlet Valve, 2nd Stage |
| 000543 | Saug-Druckventil, 3. Stufe | In- & Outlet Valve, 3rd Stage |

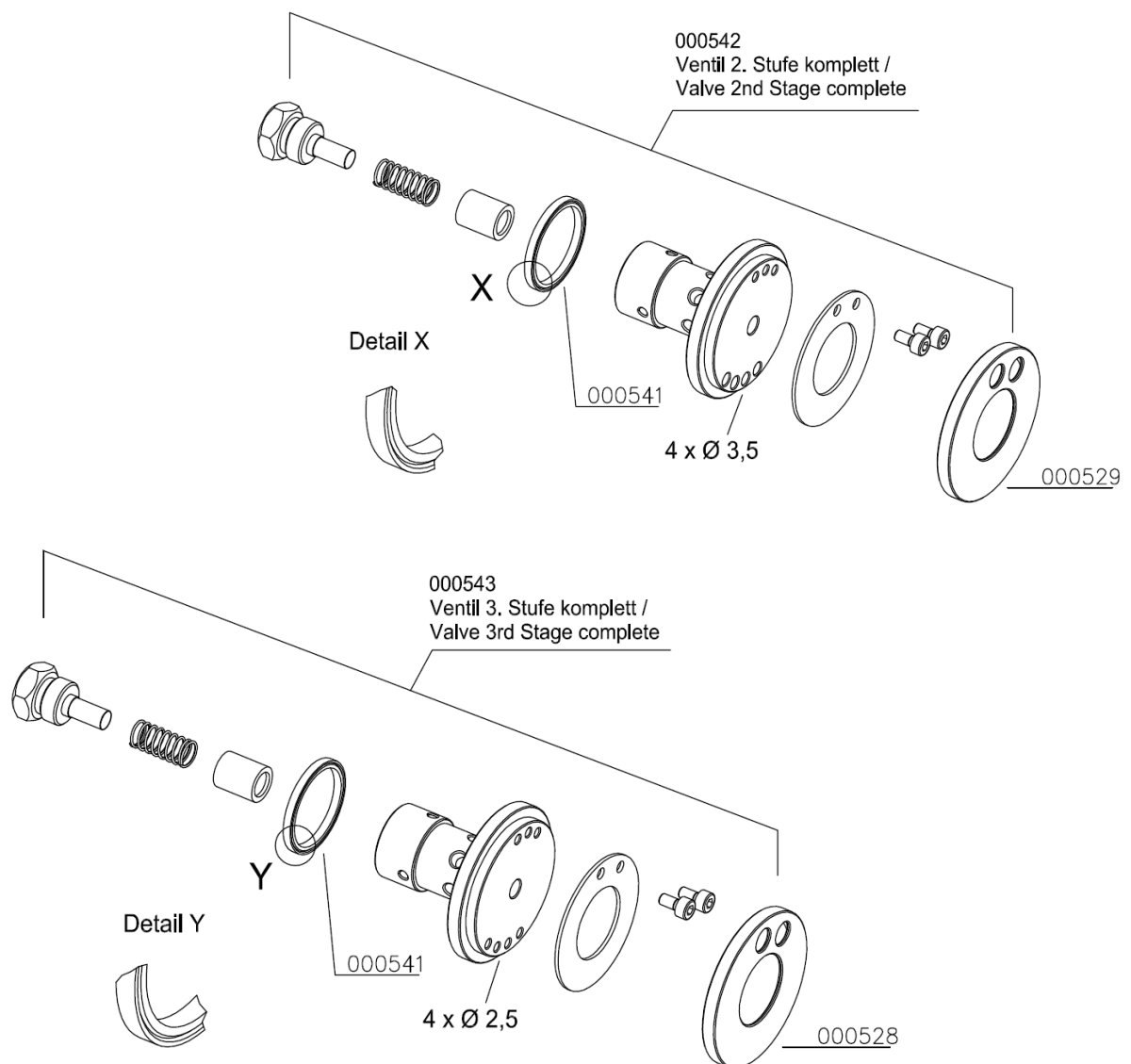



ERSATZTEILLISTE / SPARE PART LIST

Baugruppe: Ölablassschlauch / Assembly: Oil Drainage Tube

| Best.-Nr. / Order No. | Benennung | Description |
|-----------------------|------------------------------|----------------------|
| 000817 | Verschraubung | Connection |
| 001005 | Zylinderschraube | Allen Screw |
| 002153 | Ölablassschlauch | Oil drain hose |
| 006964 | Klemmhalter Ölablassschlauch | Clamp Oil Drain Hose |

C

DETAILANSICHT / DETAILED VIEW

Baugruppe: Ölablassschlauch / Assembly: Oil Drainage Tube

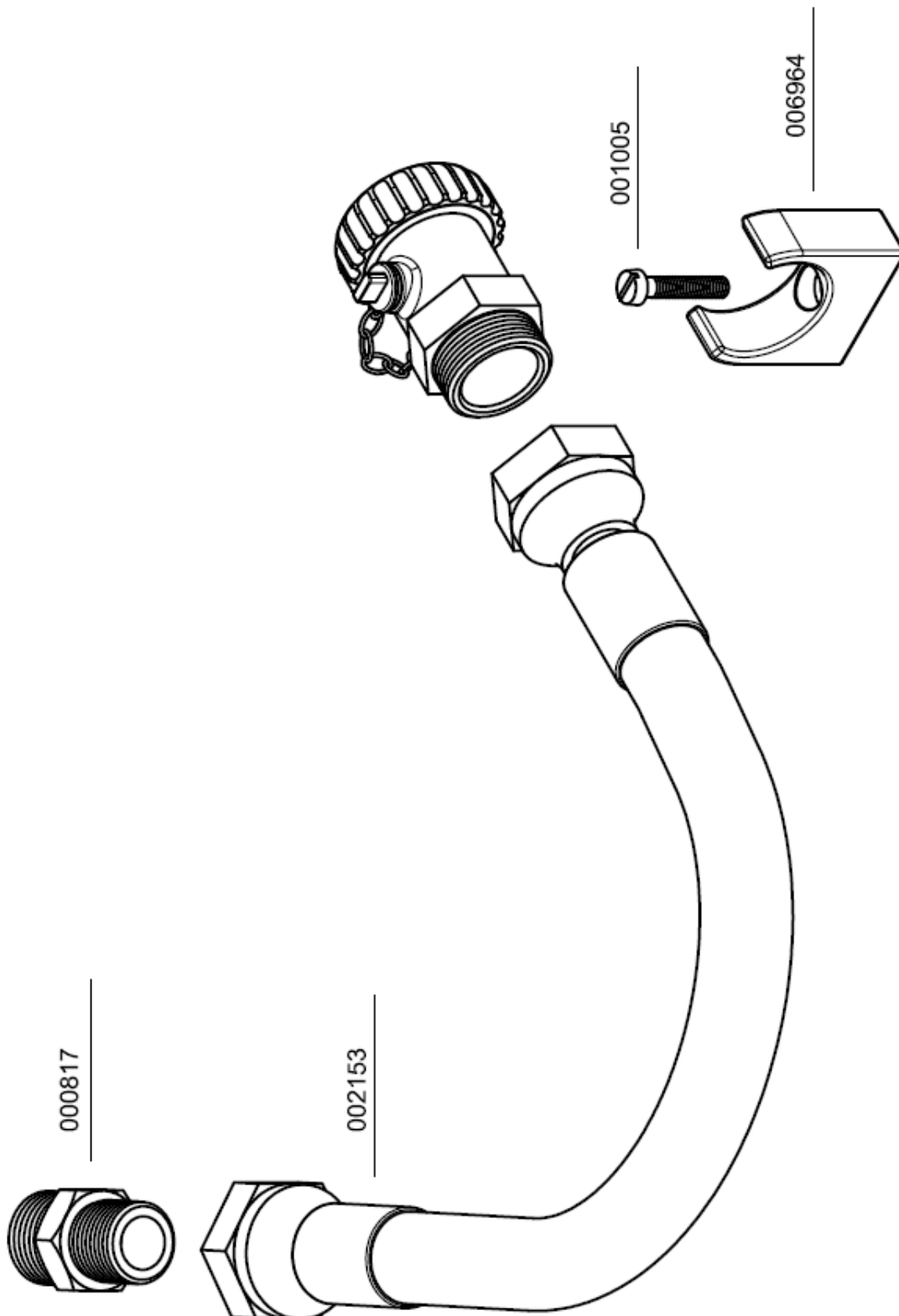



ERSATZTEILLISTE / SPARE PART LIST

Baugruppe: Ölfilter / Assembly: Oil Filter

| Best.-Nr. / Order No. | Benennung | Description |
|-----------------------|-------------------------------|--------------------------------|
| 000184 | Sinterfilter Wasserabscheider | Siltered Filter, Oil Filter |
| 000434 | Gehäuse (Ölfiltergehäuse) | Body Oil Filter Housing |
| 000435 | O-Ring, Ölfiltergehäuse | O-Ring |
| 000436 | Filterscheibe Ölfiltergehäuse | Filter Disk (oil filter assy) |
| 000437 | Filterdeckel Ölfiltergehäuse | Filter Cover (oil filter assy) |
| 000438 | Stiftschraube Ölfiltergehäuse | Threaded Bolt, oil filter assy |
| 000440 | Ölfilter kompl. | Oil Filter Unit LW 280 |
| 000498 | U-Scheibe A6 | Washer A6 |
| 000710 | Verschraubung | Connection w/o nut& olive seal |
| 000721 | Verschraubung | Connection |
| 000732 | Überwurfmutter 6L | Nut 6L |
| 001029 | Zylinderschraube | Allen Bolt |
| 001056 | Zylinderschraube | Allen Bolt |
| 001156 | Stoppmutter | Lock Nut M6 |
| 001181 | U-Scheibe A8 | Washer A8 |
| 002395 | Verschlusskegel 06mm | Locking cone 06mm |

C

DETAILANSICHT / DETAILED VIEW

Baugruppe: Ölfilter / Assembly: Oil Filter

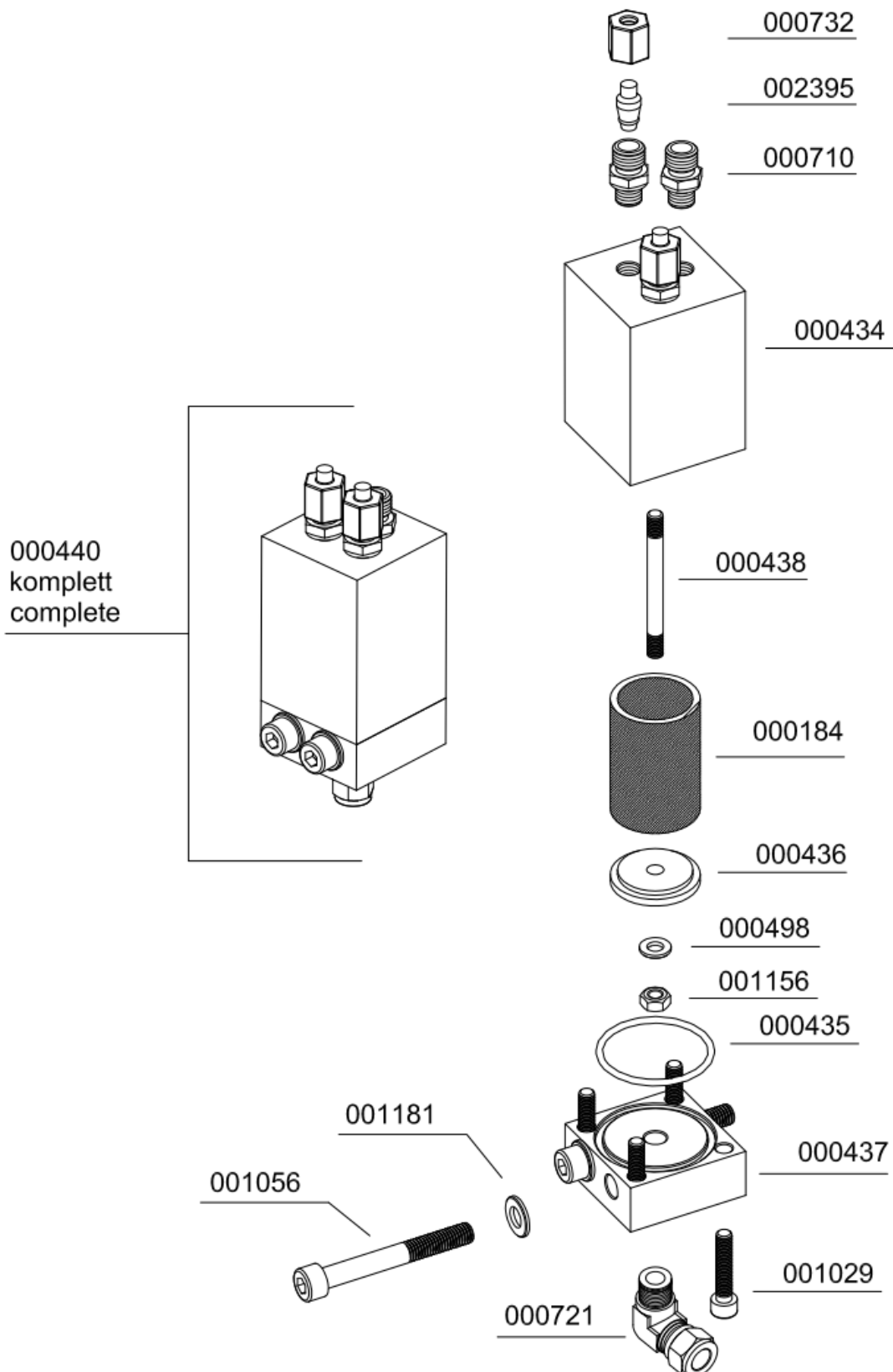

C



ERSATZTEILLISTE / SPARE PART LIST

Baugruppe: Ölpumpe / Assembly: Oil Pump

| Best.-Nr. / Order No. | Benennung | Description |
|-----------------------|-------------------------------|---------------------------|
| 000426 | Distanzbuchse, (Hauptlager) | Spacer Tube |
| 000427 | Nocke, (Hauptlager) | Cam Bush |
| 000428 | Hauptlager, (Kugellager) | Main Ball Bearing |
| 000429 | Buchse für Wellendichtring | Sleeve for Seal Ring |
| 000430 | O-Ring | O-Ring |
| 001027 | Zylinderschraube | Allen Bolt |
| 001263 | O-Ring | O-Ring |
| 001305 | O-Ring | O-Ring Viton |
| 001667 | Ölpumpe kompl. | Oil Pump, compl. Assembly |
| 002146 | Lagerflansch | Bearing flange |
| 002162 | Hauptlager | Main bearing |
| 002163 | Simmerringdeckel | Cover Shaft Seal |
| 002165 | Radial-Wellendichtring | Radial shaft seal |

C

DETAILANSICHT / DETAILED VIEW

Baugruppe: Ölpumpe / Assembly: Oil Pump

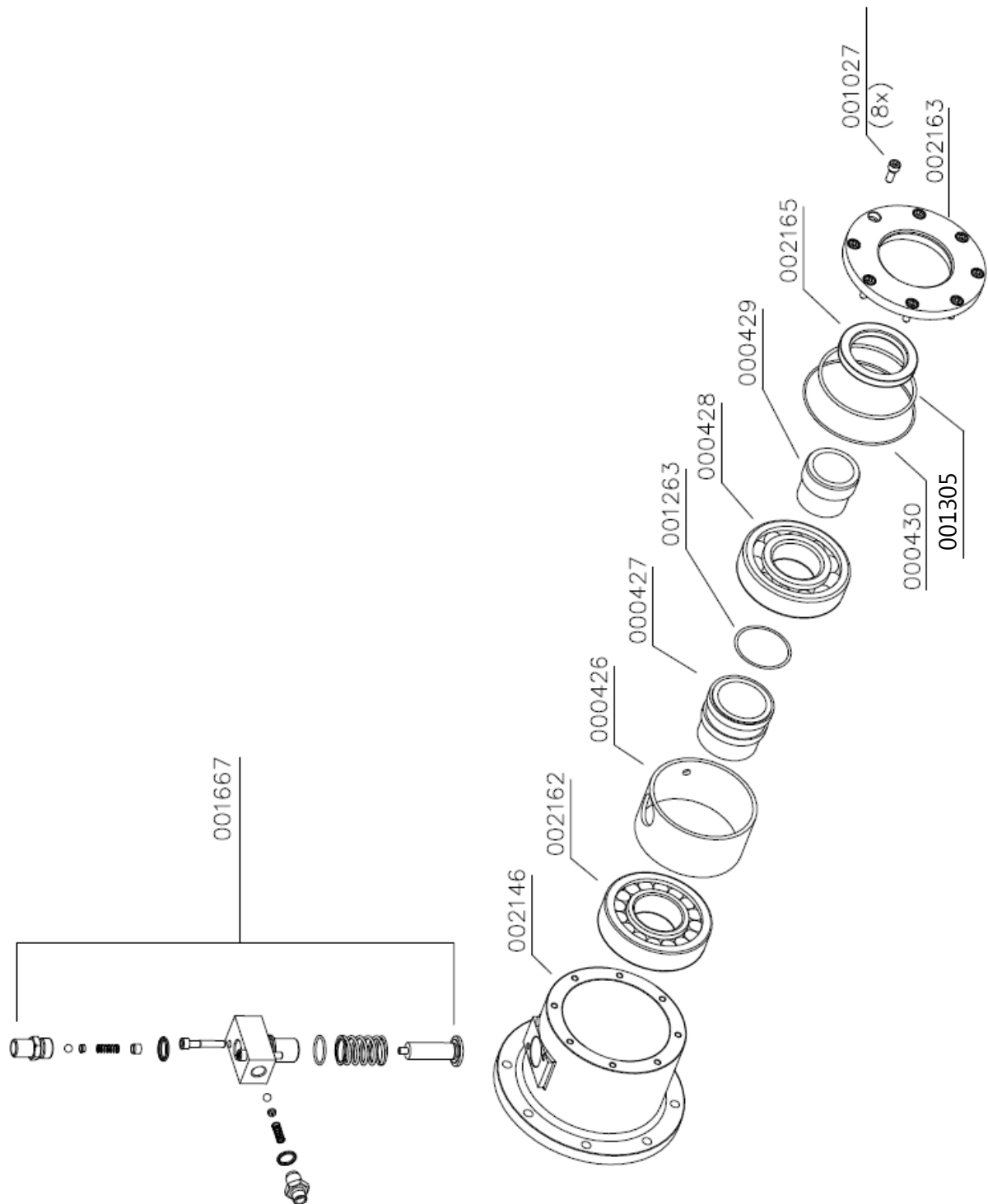



ERSATZTEILLISTE / SPARE PART LIST

Füllventile mit Schläuchen / Filling valves with hoses

| Best.-Nr. / Order No. | Benennung | Description |
|-----------------------|--------------------------------------|---------------------------------------|
| 000783 | Verschraubung | Straight Connection |
| 001437 | Hochdruckschlauch 1200mm | HP Hose 1200mm |
| 001836 | RepSatz für Kipphebelventil | Repair Kit Lever valve |
| 002019 | Schalldämpfer, Kipphebelventil G1/8" | Silencer Lever Filling Valve G1/8" |
| 003493 | Faltenbalg Kipphebelventil schwarz | Gaiter, lever valve, black |
| 003494 | Faltenbalg, Kipphebelventil rot | Gaiter, lever valve, red |
| 003778 | Kipphebelventil 200bar Kompressor | Lever filling valve compressor 200bar |
| 003779 | Kipphebelventil 300 bar Kompressor | Lever fill. valves compressor 300bar |

C

DETAILANSICHT / DETAILED VIEW

Füllventile mit Schläuchen / Filling valves with hoses

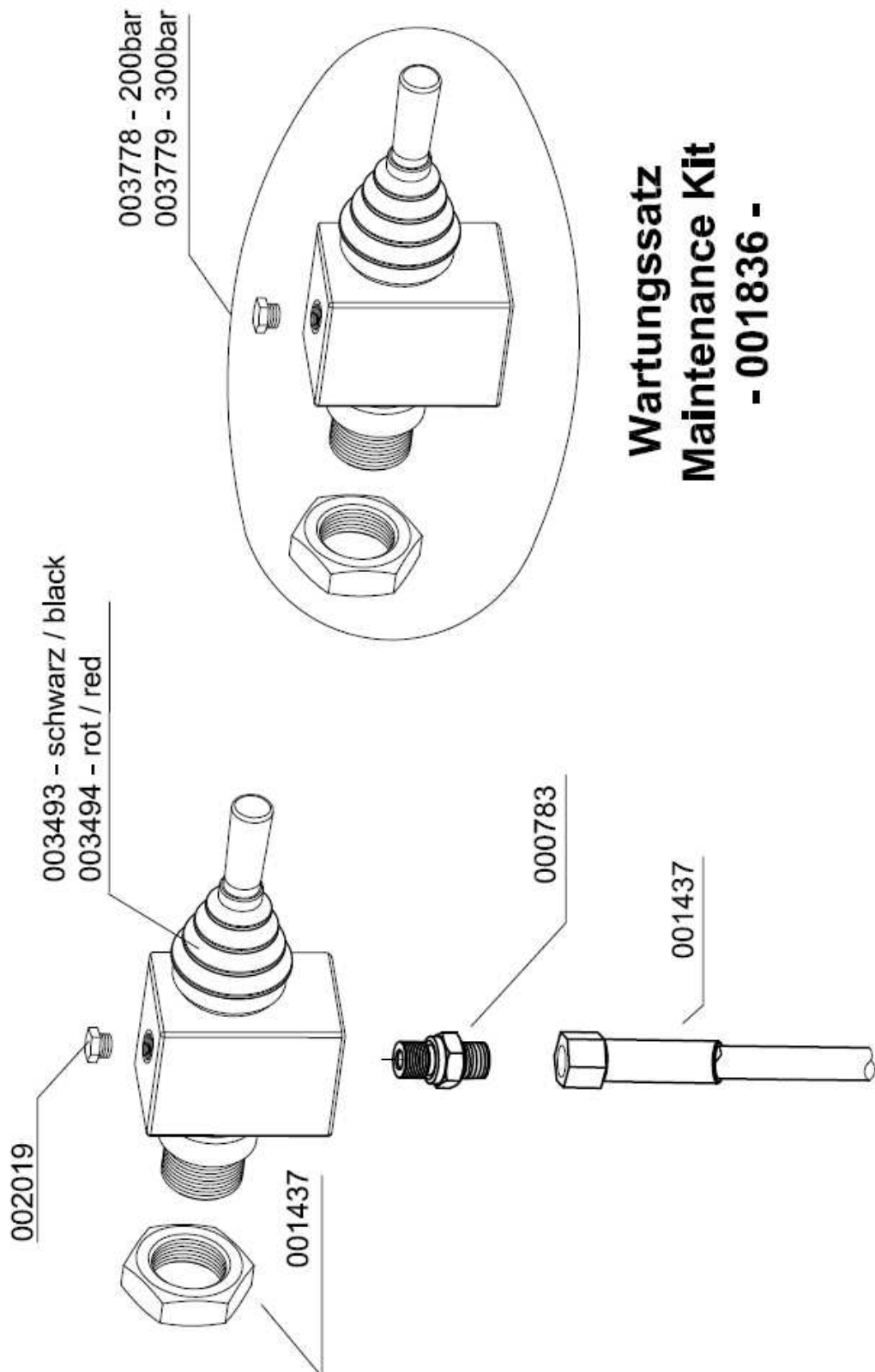



ERSATZTEILLISTE / SPARE PART LIST

Füllanschlüsse / Filling connectors

| Best.-Nr. / Order No. | Benennung | Description |
|-----------------------|--|---|
| 000213 | Handrad, schwarz DIN | Hand Wheel, black |
| 000215 | Handrad rot DIN | Hand Wheel, red |
| 000695 | Füllanschluss o. Handrad, 200bar | Filling Connector w/o handwheel 200bar |
| 000697 | Füllanschluss o. Handrad, 300bar | Filling Connector w/o handwheel 300bar |
| 000701 | Sicherheitsfüllanschluss, ohne Handrad, 200bar | Anti Whip Connector w/o handwheel, 200bar |
| 000702 | Sicherheitsfüllanschluss, ohne Handrad, 300bar | Anti Whip Connector w/o handwheel, 300bar |
| 001237 | O-Ring DIN Flaschenanschluss | O-Ring DIN filling connector |
| 002911 | Sinterfilter DIN Flaschenanschluß | Sintered filter, DIN filling connector |

C

DETAILANSICHT / DETAILED VIEW

Füllanschlüsse / Filling connectors

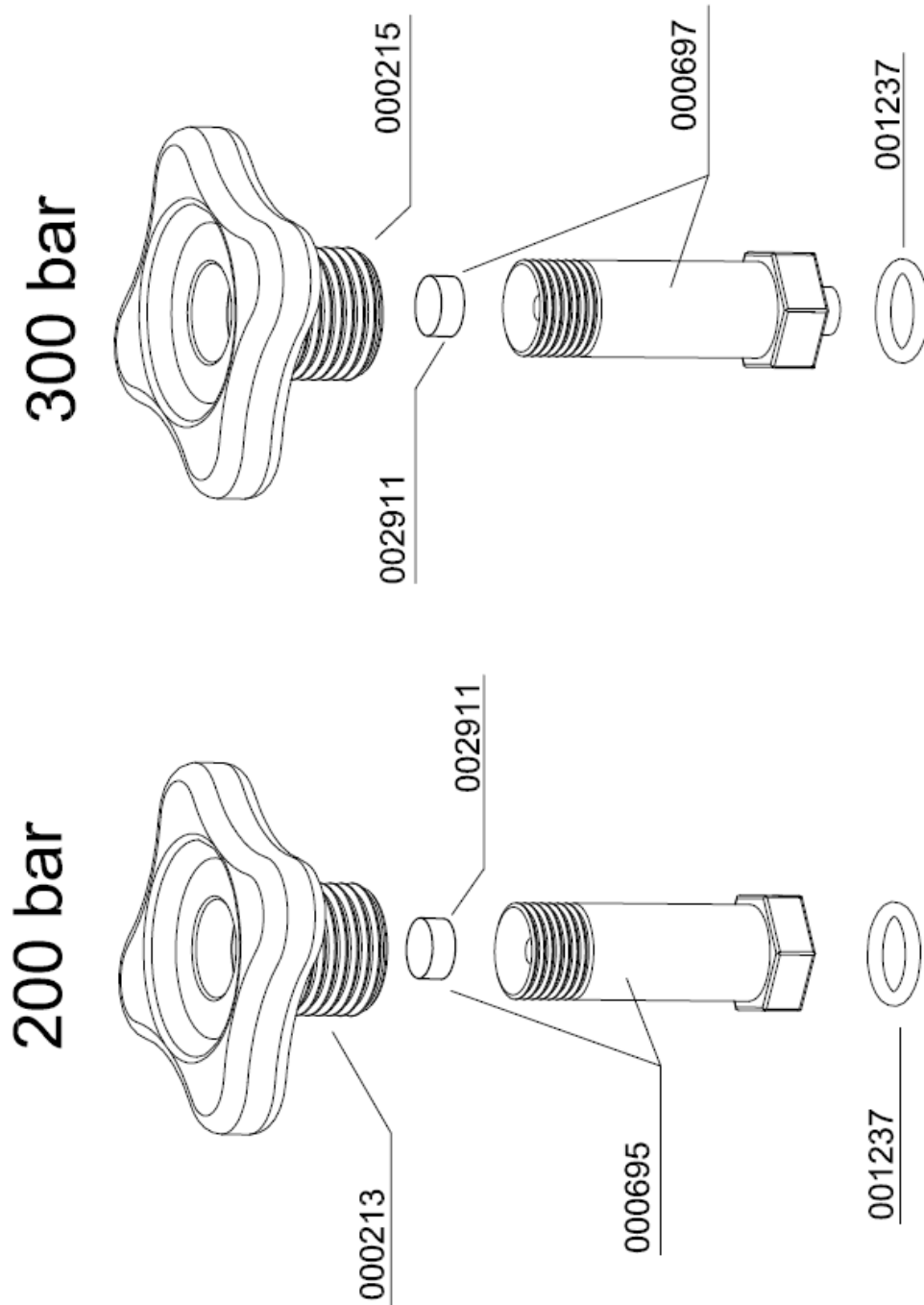

Sicherheitsfüllanschluss verfügbar
 Safety Filling Connector available
 200bar - 000701 / 300bar - 000702





OPTIONS



Table of Contents

| | |
|--|----|
| Auto Start Function | 2 |
| Oil Pressure Gauge | 7 |
| Oil Pressure Monitoring | 10 |
| Oil Temperature Monitoring | 14 |
| Interstage Pressure Gauge | 17 |
| Cylinder Head Temperature Monitoring | 21 |
| 200+300bar Parallel Filling Pressure Operation | 24 |
| Air Cooler Connection Kit..... | 28 |
| Condensate Tank 60L | 31 |



AUTO START FUNCTION

D

AUTO START FUNCTION

Auto Start Function

The auto start function allows operating the compressor optionally in automatic or semi-automatic mode by turning the selector switch.

Semi-automatic operation:

Start the compressor by pushing the Start button. The compressor automatically shuts off when final pressure is reached. To restart the compressor, push the Start button again. The unit can be shut down at any time during operation by pushing the Stop button.



Selector switch auto start function

Automatic operation:

Start the compressor only once by pushing the Start button. The Start button lights up and the unit automatically shuts off when final pressure is reached. If outlet pressure decreases below the selected minimum pressure, the unit automatically restarts.



Note

The compressor can not be manually started during automatic operation.

To enable a manual start, shut off automatic operation by pushing the Stop button (Start button lamp goes out). Now turn selector switch to semi-automatic mode and start the compressor with the Stop button.

Adjust start pressure (minimum pressure)

The pressure switch for start pressure is located after the pressure maintaining valve. The pressure can be adjusted with the upper adjusting screw.

Increasing start pressure: turn adjusting screw clockwise

Reducing start pressure: turn adjusting screw anti-clockwise

Adjust pressure switch in steps of a quarter turn. Check settings after every adjustment step.

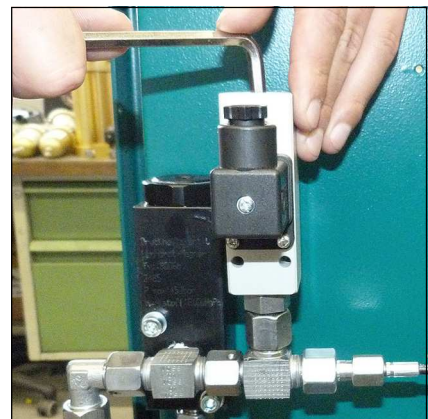

Adjust start pressure

AUTO START FUNCTION

Filling procedure semi-automatic operation



Caution! Only fill cylinders which:

- are marked with the test mark and the test stamp of the expert.
- have been hydro static tested (check last test date).
- are rated for the final pressure.
- are free from humidity.



Note

The unit shuts down when final pressure is reached. Thus, the unit always has to be restarted manually.

1. Turn selector switch to semi-automatic mode.
2. Close all filling valves.
3. Connect closed compressed air cylinders.
4. Open filling valves.
5. Start compressor by pushing the ON button.
6. When filling pressure gauge increases, open filling valves slowly.
7. Fill compressed air cylinders to the desired pressure, subsequently close filling valves slowly.
8. Close and vent all filling valves.
9. Disconnect all compressed air cylinders from filling valves.

AUTO START FUNCTION

Filling procedure automatic operation

**Caution! Only fill cylinders which:**

- are marked with the test mark and the test stamp of the expert.
- have been hydro static tested (check last test date).
- are rated for the final pressure.
- are free from humidity.

**Note**

The unit shuts down when final pressure is reached. Thus, the unit always has to be restarted manually.

1. Turn selector switch to automatic mode.
2. Close all filling valves.
3. Connect closed compressed air cylinders.
4. Open filling valves.
5. Start compressor by pushing the ON button.
6. When filling pressure gauge increases, open filling valves slowly.
7. Fill compressed air cylinders to the desired pressure, subsequently close filling valves slowly.
8. Close and vent all filling valves.
9. Disconnect all compressed air cylinders from filling valves.
10. If automatic operation is interrupted by:
 - pushing the OFF button
 - turning the selector switch
 - tripping the emergency shut-off switch
 - opening of the doors or the coverthe unit has to be restarted.

AUTO START FUNCTION

Spare part lists

| Best.-Nr. / Order No. | Benennung | Description |
|-----------------------|--------------------|-----------------|
| 000203 | Druckschalter | Pressure Switch |
| 000751 | T-Verschraubung 8L | T-Piece 8L |
| 000765 | Schneidring 8L | Olive Seal 8L |
| 000766 | Schneidring 8L | Olive Seal 8L |
| 004691 | Wahlschalter | Selector switch |
| 005663 | Einlegeschild | Label |
| 006859 | Schildträger | Label holder |

D

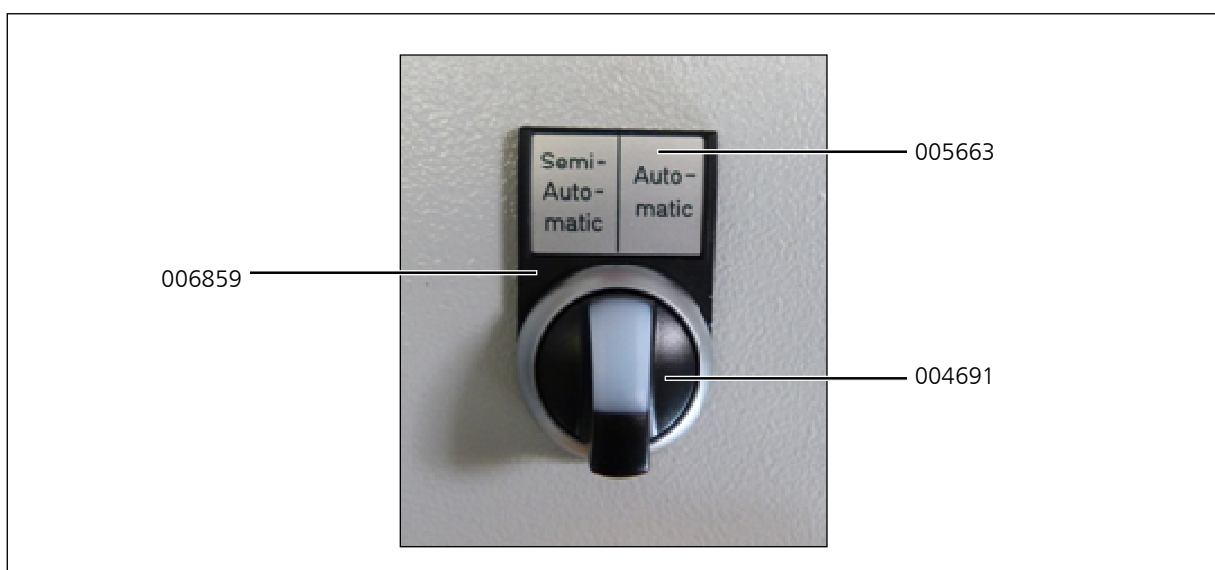
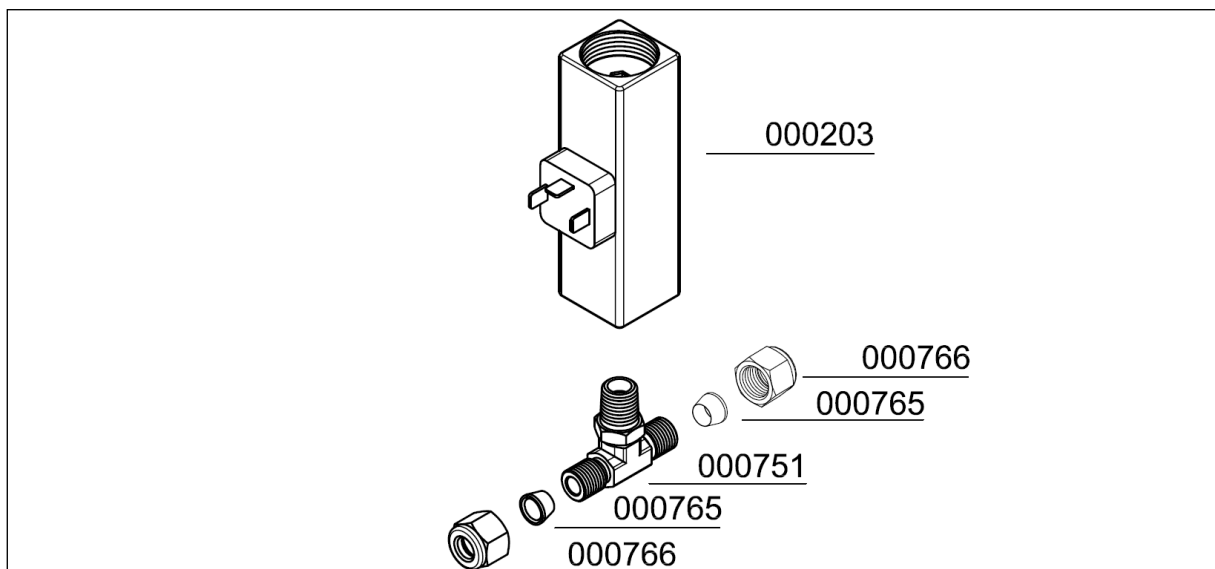



OIL PRESSURE GAUGE

D

OIL PRESSURE GAUGE

Oil pressure gauge

The oil pressure gauge shows the compressor oil pressure during operation. Oil pressure values should remain between:

- min. + 0.5 bar
- max. + 4.0 bar

If oil pressure value stays below the minimum value:

- Wrong compressor rotation direction (see rotation direction arrow)
- Oil level too low, not enough oil in the compressor
- Oil pump filter contaminated
- Oil intake pipe damaged / defective
- Oil temperature below +5 °C - lubrication not possible
- Oil temperature higher than +120 °C - oil viscosity too low
- Oil pump defective

If oil pressure value stays above the maximum value:

- Low oil temperature, between +5 °C and +10 °C
- Should stay within the range of tolerance when operation temperature is reached..



Oil pressure gauge

OIL PRESSURE GAUGE

Spare part lists

| Best.-Nr. / Order No. | Benennung | Description |
|-----------------------|--------------------------|-------------------------------|
| 001447 | Manometerschlauch 800mm | Hose for Pressure Gauge 800mm |
| 002507 | Öldruckmanometer 0-10bar | Oil Pressure Gauge 0-10bar |

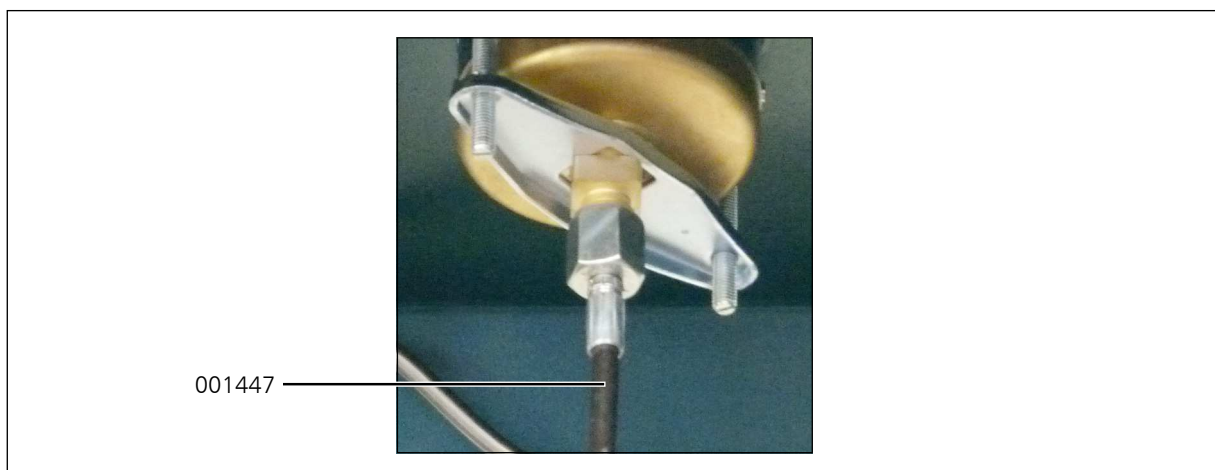
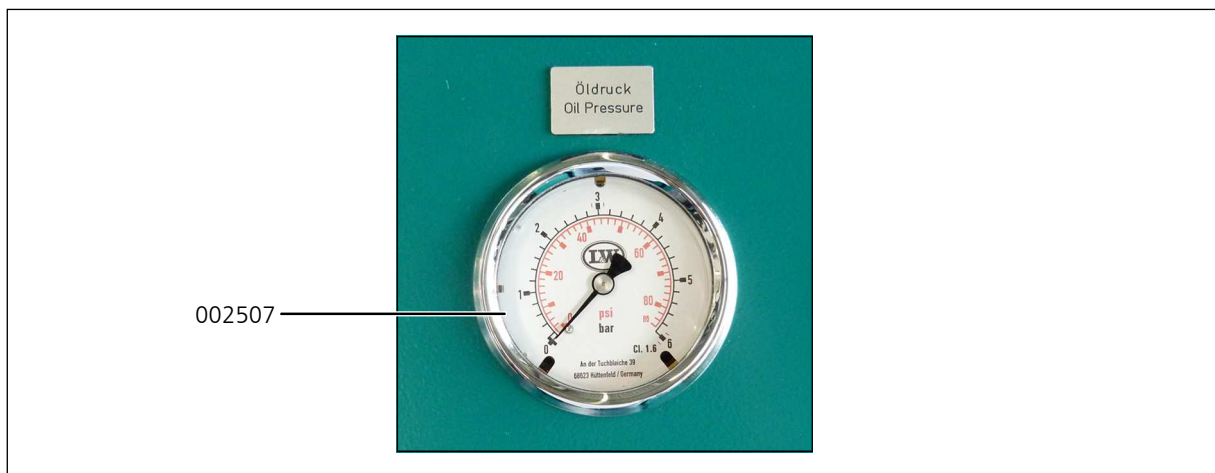



OIL PRESSURE MONITORING

D

OIL PRESSURE MONITORING

Oil pressure monitoring

The oil pressure is maintained by a pressure switch during operation. The compressor automatically shuts off when oil pressure decreases below the minimum pressure of +0.5 bar. The red warning lamp "Oil Pressure Monitoring" lights up.

Possible causes of fault:

- Wrong compressor rotation direction
(see rotation direction arrow)
- Oil level too low, not enough oil in the compressor
- Oil pump sieve contaminated
- Oil intake hose damaged / defective
- Oil temperature below +5 °C - lubrication not possible
- Oil temperature higher than +120 °C - oil viscosity too low
- Oil pump defective



Oil Pressure Monitoring



OIL PRESSURE MONITORING

Spare part lists

| Best.-Nr. / Order No. | Benennung | Description |
|-----------------------|----------------------|-------------------------|
| 000722 | Winkelverschraubung | Elbow Connection |
| 004701 | Warnlampe | Warning Lamp |
| 004703 | Schild | Label |
| 004704 | Relais für Warnlampe | Relais for warning lamp |
| 005261 | Öldruckschalter | Oil Pressure Switch |
| 006631 | Rohrleitung | Pipe |
| 006859 | Schildträger | Label holder |

D

OIL PRESSURE MONITORING

Spare part lists

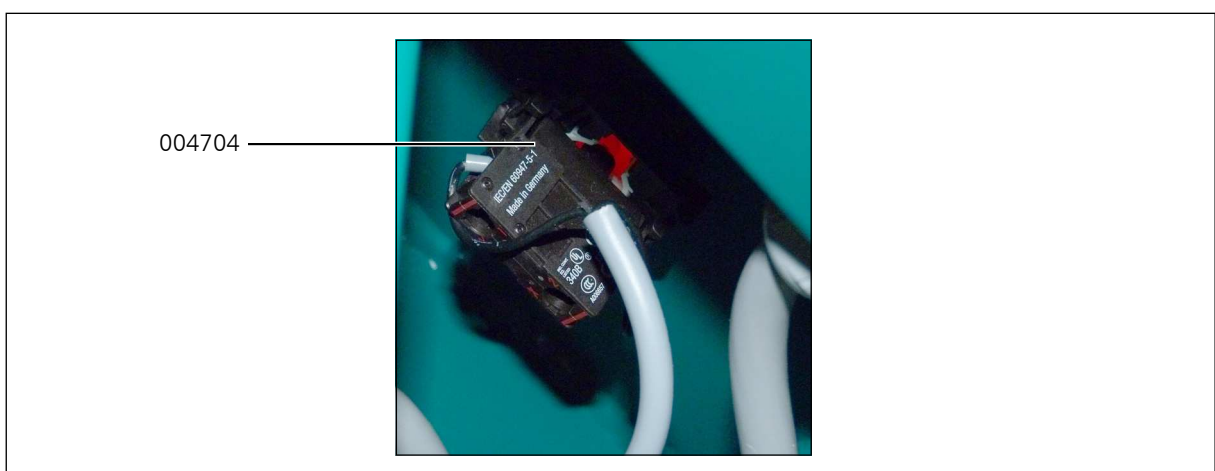
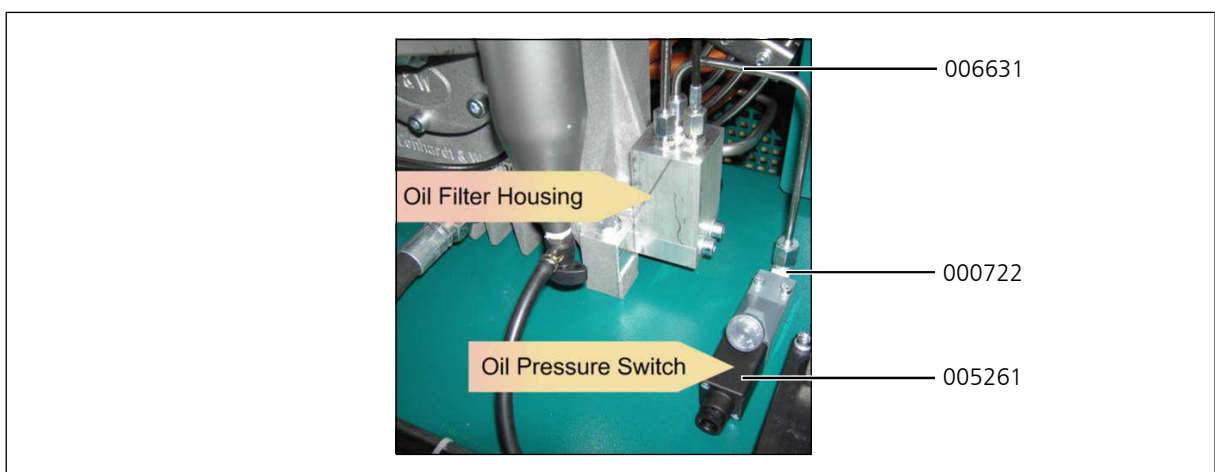

D



OIL TEMPERATURE MONITORING

D

OIL TEMPERATURE MONITORING

Oil temperature monitoring

Oil temperature monitoring

The oil temperature is maintained by a temperature sensor inside the compressor block during operation.

The compressor automatically shuts off when oil temperature exceeds the maximum pressure of +120 °C. The red warning lamp "Oil Temperature Monitoring" lights up.

Possible causes of fault:

- Ambient temperature too high
- Cooling air flow not sufficient
- Oil level too low
- Cooling pipes contaminated



Oil Temperature Monitoring



Warning

Risk of burns!

Allow the unit to cool before beginning troubleshooting.

OIL TEMPERATURE MONITORING

Spare part lists

| Best.-Nr. / Order No. | Benennung | Description |
|-----------------------|--------------------|--------------------|
| 004342 | Display | Display |
| 004730 | Display und Sensor | Display and Sensor |



D



INTERSTAGE PRESSURE GAUGE

D

INTERSTAGE PRESSURE GAUGE

Interstage pressure gauge

Each of the 3 pressure stages is monitored by a single pressure gauge. This is serviceable for troubleshooting and allows detecting faults at an early stage.



Indicated interstage pressures depend on final pressure settings.

The pressure gauges should show the following values at a final pressure of 300 bar:

1st stage: approx. 5 bar

2nd stage: approx. 42 bar

3rd stage: approx. 300 bar



INTERSTAGE PRESSURE GAUGE

Spare part lists

| Best.-Nr. / Order No. | Benennung | Description |
|-----------------------|-----------------------------|-----------------------------------|
| 000660 | Manometer 0-60 bar | Pressure Gauge 0-60 bar |
| 000663 | Manometer 0-400 bar | Pressure Gauge 0-400 bar |
| 000710 | Verschraubung (1/8" -> 6L) | Connection (1/8" -> 6L) |
| 001445 | 6L Manometerschlauch 600 mm | 6L Hose for Pressure Gauge 600 mm |
| 002507 | Manometer 0-10 bar | Pressure Gauge 0-10 bar |

D

INTERSTAGE PRESSURE GAUGE

Spare part lists

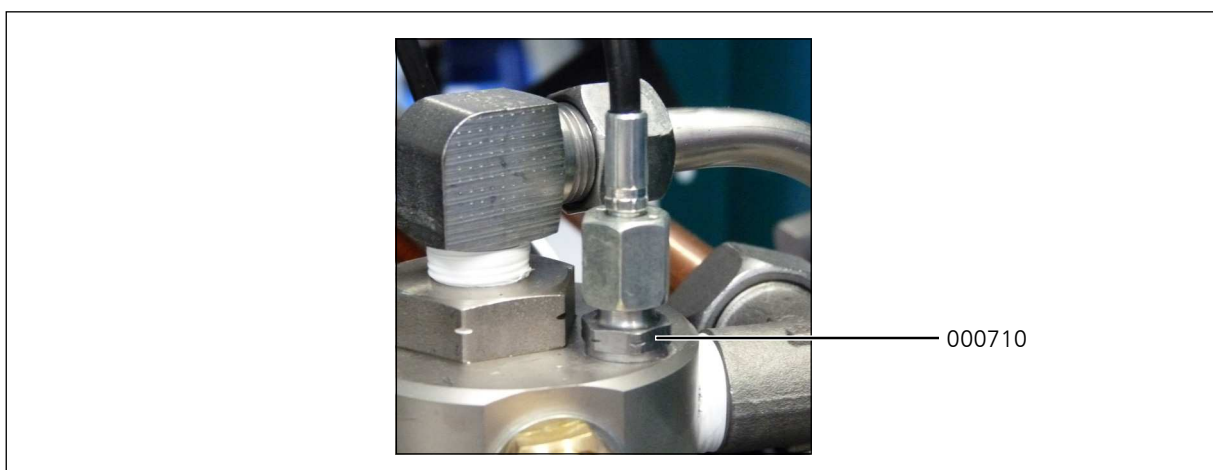
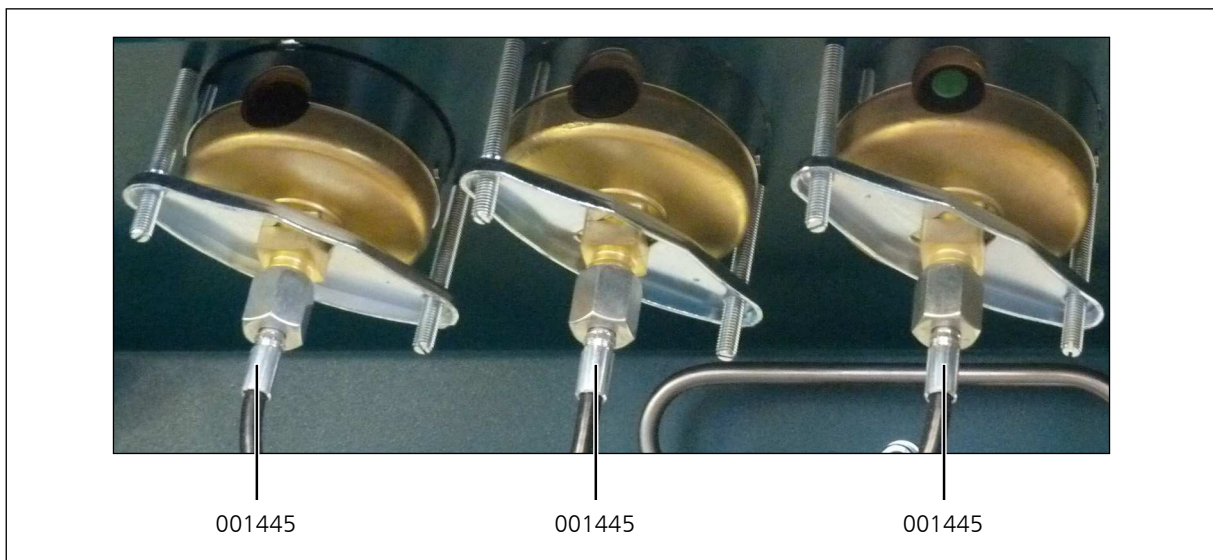
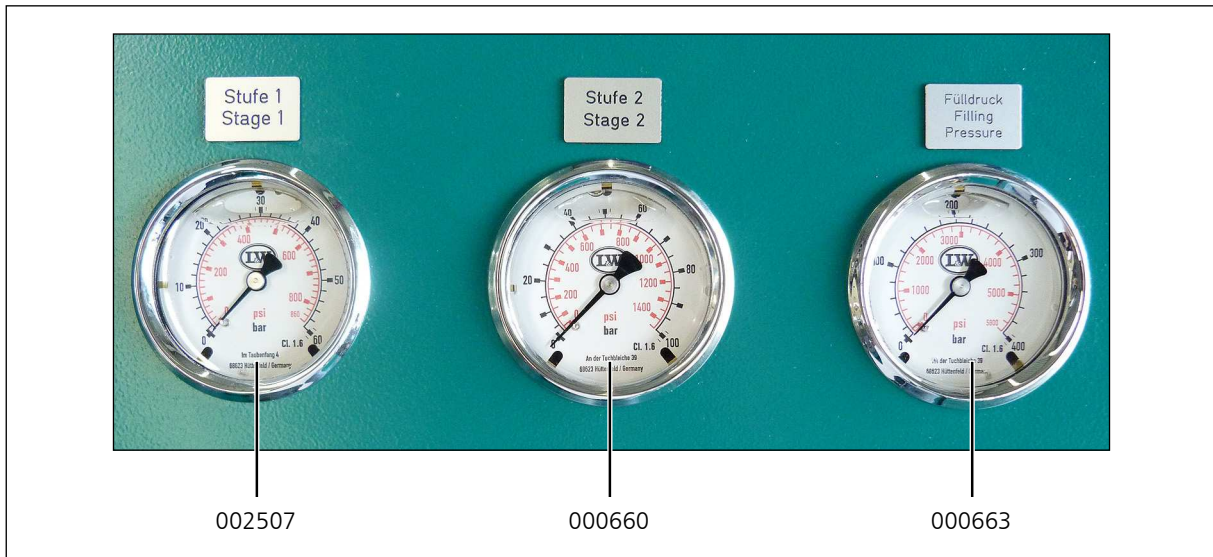



CYLINDER HEAD TEMPERATURE MONITORING

D

CYLINDER HEAD TEMPERATURE MONITORING

Cylinder head temperature monitoring

The cylinder head temperature is maintained by a temperature sensor at the cylinder head of the high pressure stage during operation. The compressor shuts off automatically when cylinder head temperature exceeds the maximum pressure of +160° C. The red warning lamp "Cylinder Head Temperature Monitoring" lights up.

Possible causes of fault:

- Ventilation of the compressor room is not sufficient
- Cooling air flow not sufficient
- Cooling pipes contaminated



Warning

Risk of burns!

Allow the unit to cool before beginning troubleshooting.

CYLINDER HEAD TEMPERATURE MONITORING

Spare part lists

| Best.-Nr. / Order No. | Benennung | Description |
|-----------------------|--------------------------------|------------------------------|
| 004726 | Display | Display |
| 005585 | Sensor | Sensor |
| 007444 | Ventilkopf (Spezielle Version) | Valve Head (special version) |

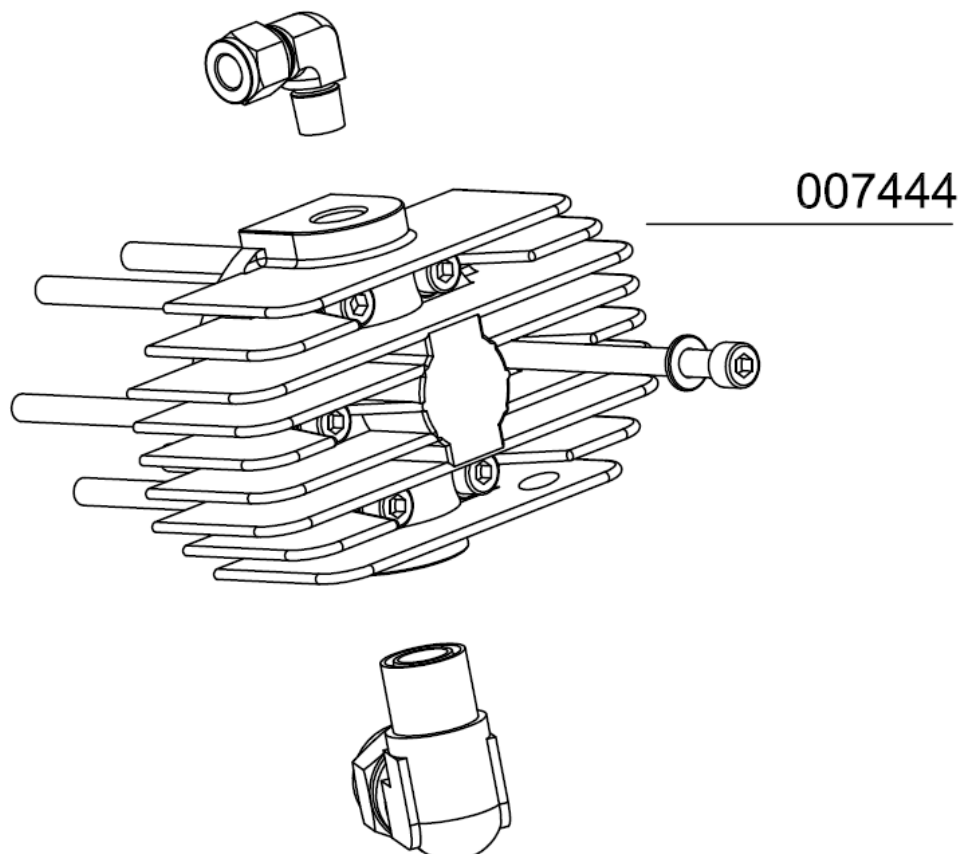
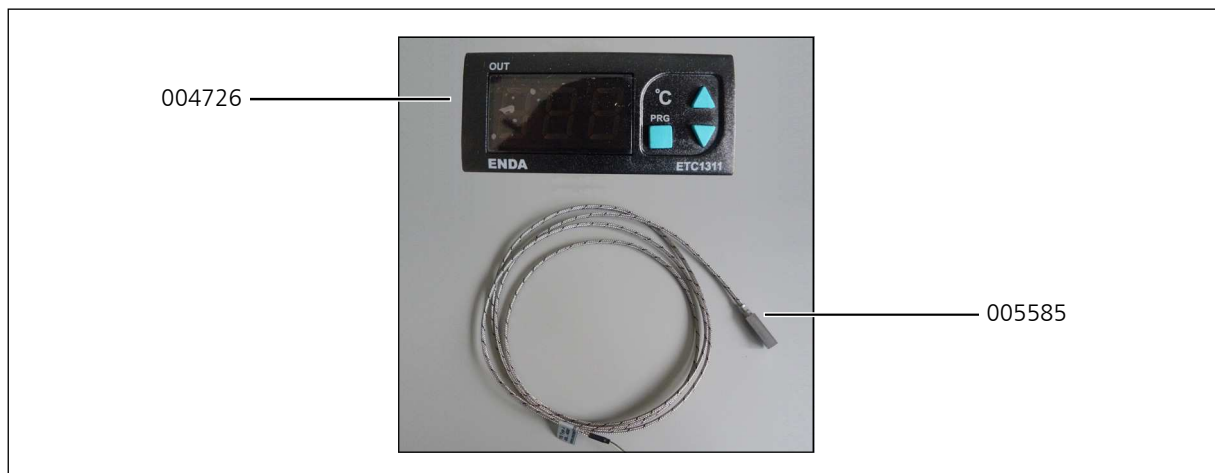



**200 / 300 BAR
PARALLEL FILLING
PRESSURE OPERATION**

D

200 / 300 BAR PARALLEL FILLING PRESSURE OPERATION

200 bar / 300 bar parallel filling pressure operation

This option allows the filling of 200 bar and 300 bar at the same time.

In this case, the compressor is equipped with a pressure reducer, a second final pressure safety valve and a second filling pressure gauge.

The handwheels or gaiters are colour-coded to allow an optical differentiation:

- 200 bar: black
- 300 bar: red

Furthermore, the corresponding filling pressures at the compressor are marked with labels.



DIN handwheels 200 bar and 300 bar



Fig. Pressure reducer: 330 / 225 bar



200 / 300 BAR PARALLEL FILLING PRESSURE OPERATION

Verrohrung 2 Druckbereiche / Spare Part List: Piping 2 Pressure Ranges

| Best.-Nr. / Order No. | Benennung | Description |
|-----------------------|---|---------------------------------|
| 000233 | Sockel für Sicherheitsventil mit TÜV/CE | Base f. Safety Valve TÜV type |
| 000738 | Verschraubung 8L | Connection 8L |
| 000747 | Verschraubung NPT-8L | Connection NPT-8L |
| 000749 | Verschraubung mit fester Mutter 8L | Connection with fixed nut 8L |
| 000753 | T-Verschraubung 8L | T-Connection 8L |
| 000857 | Reduzierung 8/6L | Reducer with fixed nut 8/6L |
| 001428 | Druckminderer "High Flow" einstellbar | Pressure Reducer-Bolt version |
| 004165 | Halteblech Sicherheitsventilsockel | Bracket for Safety valve base |
| 004932 | Verschraubung für 001428 | Connection for 001428 |
| 007823 | Verschraubung mit fester Mutter 8S/8L | Connector with fixed nuts 8S/8L |

D

200 / 300 BAR PARALLEL FILLING PRESSURE OPERATION

Verrohrung 2 Druckbereiche / Spare Part List: Piping 2 Pressure Ranges

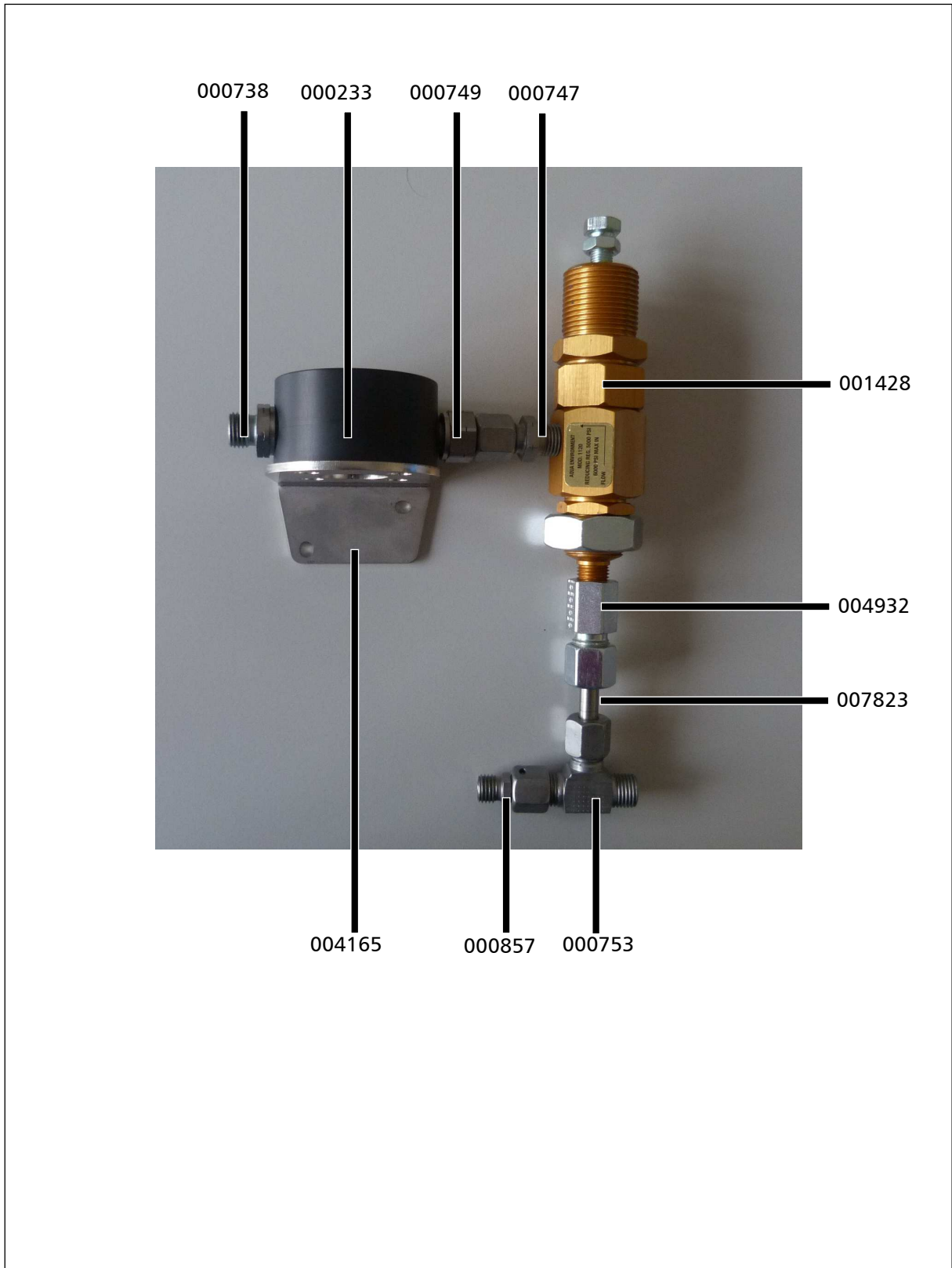

D



AIR COOLER CONNECTION KIT

D

AIR COOLER CONNECTION KIT

Air cooler connection kit

The Air Cooler Connection Kit provides an easy connection and a simple and time-saving installation or backfitting.

The piping inside the compressor is completely installed. Just disconnect the U-connection at the outside and connect the air cooler according to the connection designation (inlet/outlet).

To operate the unit without air cooler, reinstall the U-connection and the compressor is ready for use.



Air cooler connection kit

D

All length of high pressure hoses available

The Air Cooler Connection Kit does not include the high pressure hoses. So you can't find any part numbers of our hoses in this chapter. We have a wide range of high pressure hoses in our product range. Please ask if you need special lengths.

AIR COOLER CONNECTION KIT

Spare part lists

| Best.-Nr. / Order No. | Benennung | Description |
|-----------------------|---------------------|------------------------|
| 000902 | Schottverschraubung | Elbow Bulkhead Fitting |
| 006860 | Rohrbogen | U-Connection |

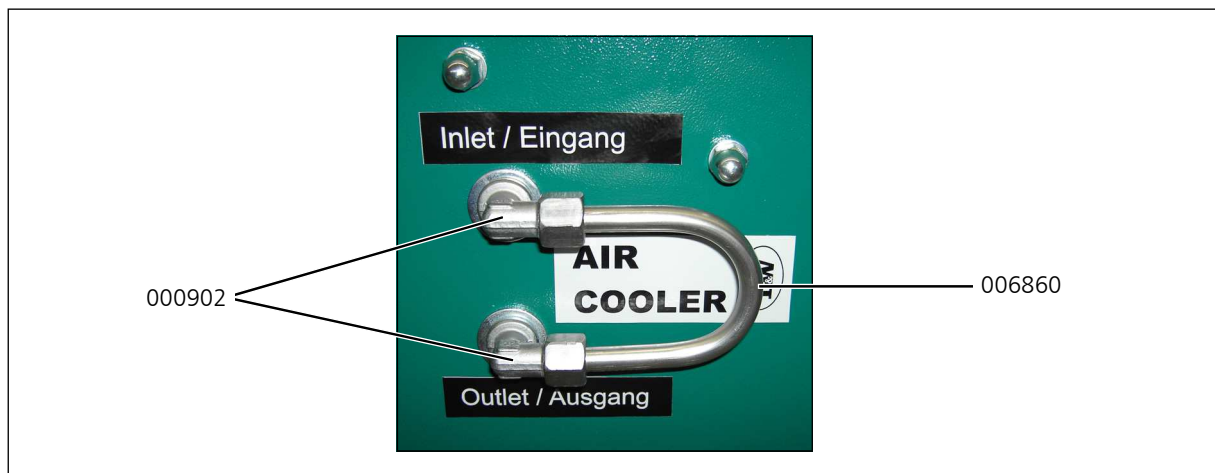

D



CONDENSATE TANK 60 LTR.

D

CONDENSATE TANK 60 LTR.

The 60 ltr. tank is equipped with an active carbon filter to collect condensate odourlessly and quietly. The condensate can be easily transported in the collecting tank and disposed environmentally sound.

The flexible connection hoses are fitted with quick-couplings, to allow easy separation from the compressor. The tank is equipped with a level gauge to indicate max. filling level. Two sturdy carrying handles ensure a safe transportation.

Technical Data:

- Dimensions: Ø 400 mm x 800 mm
- Weight: 20 kg



D

CONDENSATE TANK 60 LTR.

Maintenance and service

How to change the activated carbon and the metal filter insert

- Shut down the unit
- Plug out the condensate hoses
- Remove the protector cap, the nut and the allen bolts (Fig. 1)
- Take down the cover plate and the upper felt. Tip out the activated carbon and replace the lower felt
- Fill up the activated carbon and cover it with a new felt
- Put on the cover plate, screw the allen bolts and the nut and plug on the protector cap
- Unscrew the filter housing
- Remove the floater and the lower cover plate (Fig. 2)
- Take a pliers and pull the metal filter out of the metal case
- Insert the metal filter
- Install the cover plate and the floater
- Screw the filter housing onto the tank
- Plug in the condensate hoses

Maintenance intervals

We recommend to change the activated carbon if it has reached the saturation level (smell of oil).

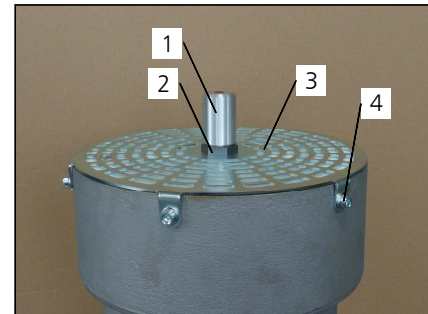

Fig. 1

- 1 Protector cap
- 2 Nut
- 3 Cover plate
- 4 Allen bolts (6x)

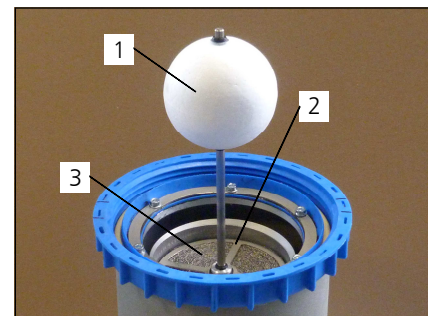

Fig. 2

- 1 Floater
- 2 Lower cover plate
- 3 Metal filter

CONDENSATE TANK 60 LTR.

Spare part lists

| Best.-Nr. / Order No. | Benennung | Description |
|-----------------------|---|-----------------------------------|
| 003091 | Kondensatbehälter 60 Liter | Condensate Tank 60L |
| 004056 | Kondensatschläuche Kondensatbehälter 60L, für 3- | Set of condensate hoses, 3 stages |
| 004057 | Kondensatschläuche Kondensatbehälter 60L, für 4- | Set of condensate hoses, 4 stages |

D

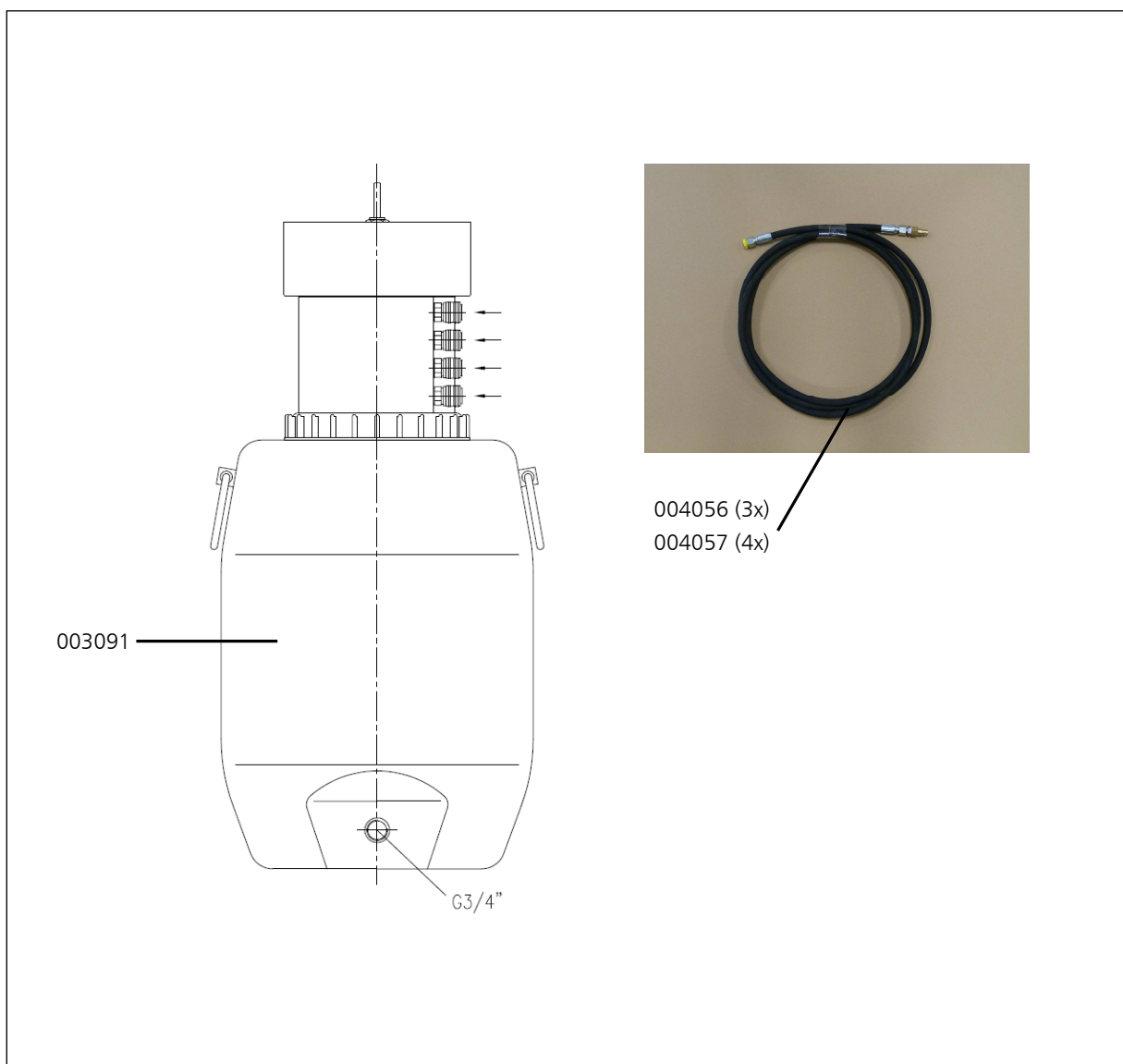

CONDENSATE TANK 60 LTR.

Spare part lists

| Best.-Nr. / Order No. | Benennung | Description |
|-----------------------|---|------------------------------------|
| 000508 | USIT-Ring 13,7 x Ø20 x 1,5 | Gasket Ring U-Sit 13,7 x Ø20 x 1,5 |
| 003866 | Filter Nachfüllset für 60 Liter | Filter refill set 60 ltr |
| 004789 | Schnellkupplung G1/4", DN 7,2 | Quick connector G1/4", DN 7,2 |
| 006642 | Metallgestrick für Kondensatbehälter 60 ltr | Metal filter insert 60 ltr tank |

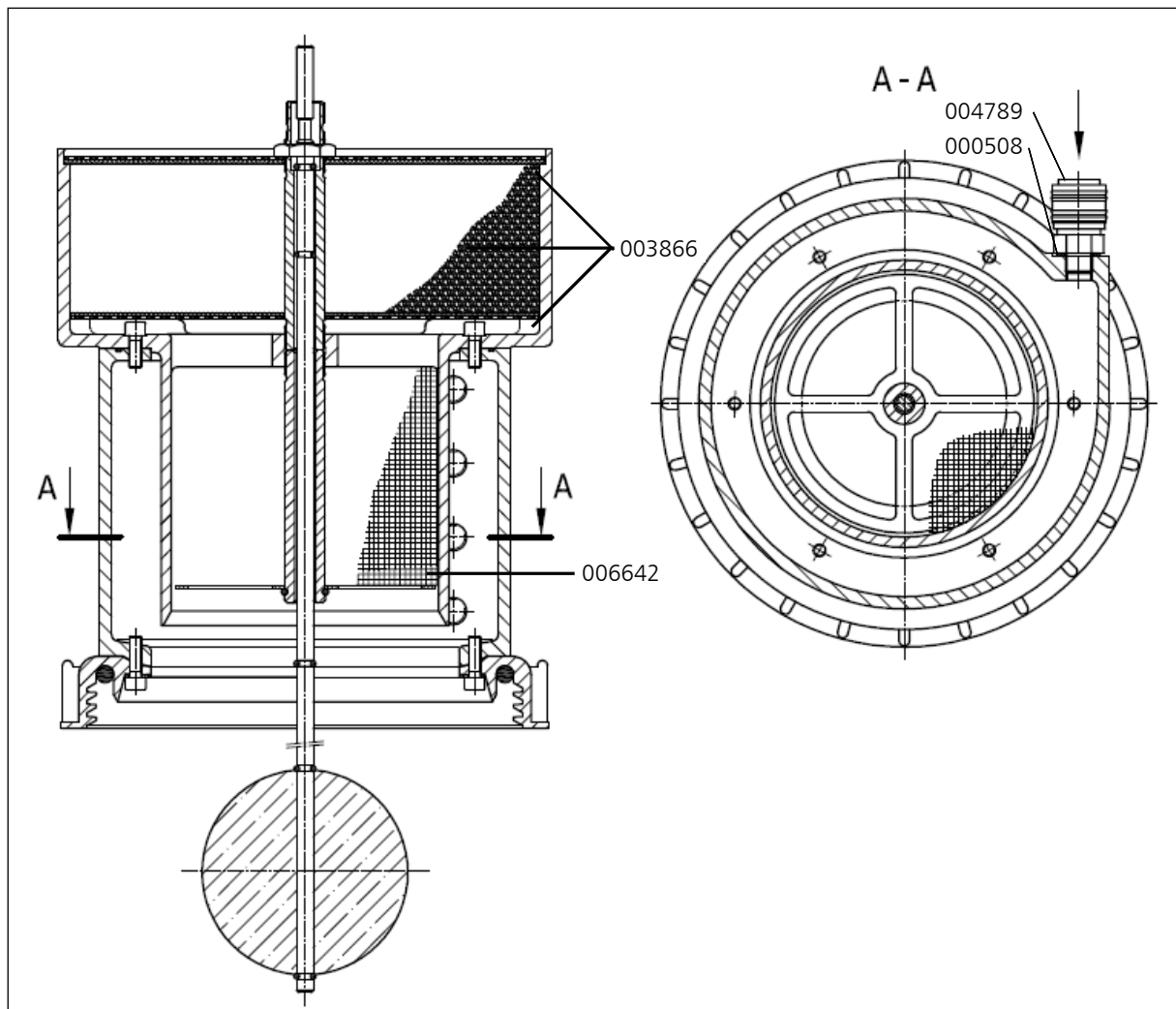

D



ATTACHMENT

E

Lenhardt & Wagner GmbH

**An der Tuchbleiche 39
D-68623 Lampertheim – Hüttenfeld**

www.lw-compressors.com



Operating Instruction

Safety valve

Typ:

SiV2 BKZ 989 TÜV.SV.12-989.5.G.V.P CE 0091 AlMgSi1 F31 1100* Lenhardt & Wagner

SiV BKZ TÜV.SV.14-1140.5.G.V.p CE 0091 AlMgSi1 F31 1100* Lenhardt & Wagner

| | |
|-------------------------|--|
| Set pressure: | see mark (hand wheel on top of valve) |
| Maximum outflow: | Set pressure 100-159 bar: 750 l / min Set pressure 160-350 bar: 1.100 l / min |
| Suitable media: | Media-resistant, non-corrosive gases |

The safety valve is used for protection of pressurized components, eg pipelines, pressure vessels, or the compressor itself.

The hand wheel on the top of the safety valve is marked with the adjusted set pressure.



Safety valve with socket

- 1) *Identification of set pressure*
- 2) *Seal*
- 3) *Fixing screws¹*
- 4) *Venting screw (hand wheel)*
- 5) *Identification serial number*
- 6) *Socket for safety valve*

¹ und die Anforderungen des AD 2000 Merkblatts W7 erfüllen. Schaftlänge 70mm. The fixing screws M8 must be strength class 8.8 and meet the requirements of Merkblatt AD 2000 leaflet W7. Shaft length 70mm.

In order to prevent manipulation of the set pressure, all safety valves are factory fitted with a seal.

A safety valve on which the seal has been removed, must be returned before further use to the manufacturer for repair / adjustment.

In addition, the safety valve has a venting device (hand wheel).

In the rotation direction clockwise, the safety valve and herewith also the filter housing of the final stage could be completely vented.

During normal operation, the screw is unscrewed to the upper stop anticlockwise, an integrated safety ring prevents that the screw can be completely unscrewed.

If a safety valve blow off, the system must be switched off immediately and investigate the cause of the error.

There are two possible reasons:

1. The safety valve is defective and blows off before the set pressure.

In this case the safety valve should be submitted immediately to the manufacturer for repair or replaced with a new one.

2. The safety valve opens properly, the problem is on the system.

A constant blowing of the safety valve is not permitted, the sealing seat of the valve can be damaged. The error on the system must be detected and repaired before further filling operations.

The safety valve may only be used if it is ensured that the maximum flowrate of the system does not exceed the blowoff rate of the safety valve.

The safety valve may only be used with the approved media.

Repair work on compressors must only be performed by trained personnel.

Dismantling of the safety valve

Ensure that on the safety valve is no pressure.

Loosen and remove the two M8 fixing bolts with a 6mm Allen key.

The safety valve can now be removed by turning and simultaneously pulling out of the socket.

Mounting

1. Clean the safety valve socket.

2. Oil the insert pin of the safety valve including the O-ring with 1 to 2 drops of oil.

3. Press the safety valve pin complete into the socket.

4. Fasten the safety valve with the two 8 mm allen screws into the socket

(Tightening torque: 10 Nm)

5. Screw the venting screw (hand wheel) anticlockwise to its upper limit.

6. Start the System (Compressor), check installation for leaks and proper function.

Manufacturer: Lenhardt & Wagner GmbH
An der Tuchbleiche 39
D-68623 Lampertheim – Hüttenfeld

Kontakt: E-Mail: service@lw-compressors.com
Web: www.lw-compressors.com
Tel.: +49 (0) 6256 – 85880 0
Fax: +49 (0) 6256 – 85880 14

Note:

*Use the safety valve only in a technically perfect condition, for its intended purpose, safety and danger awareness, in compliance with the operating instructions!
Especially disorders which could affect safety must be remedied immediately!*

Notes:

- The safety valve must be installed directly on the protected pressure vessel and / or the plant.
 - The safety valve must be installed in an upright position.
 - The flow area of the port must be greater than the valve opening.
 - Protect valve against splashes
-

Maintenance:

- The safety valve is periodically - in accordance with the currently valid Pressure Equipment Directives - to check on operation and reliability.
- Refill annually lubricating oil:
Oil filling position:
Hole on the spacer (see arrow, Figure 1)
- Oil level: Fill oil into the hole until oil comes out of the hole.

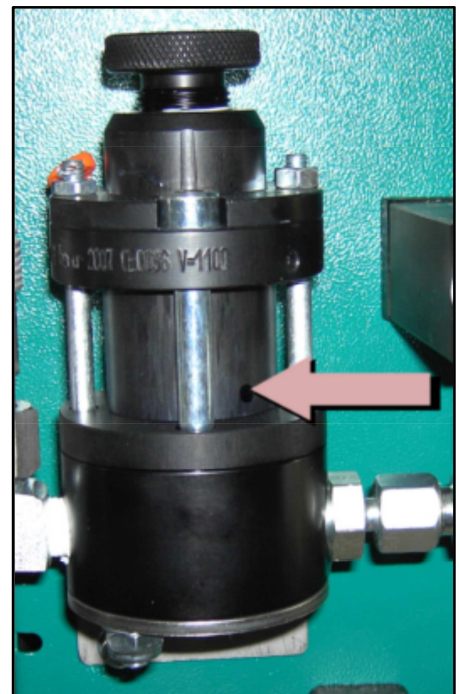

Figure 1: Position for oil refill

To be used lubricating oil for the safety valve: L&W Article Nr.: 008500 (content: 30 ml)
